

## FF Series

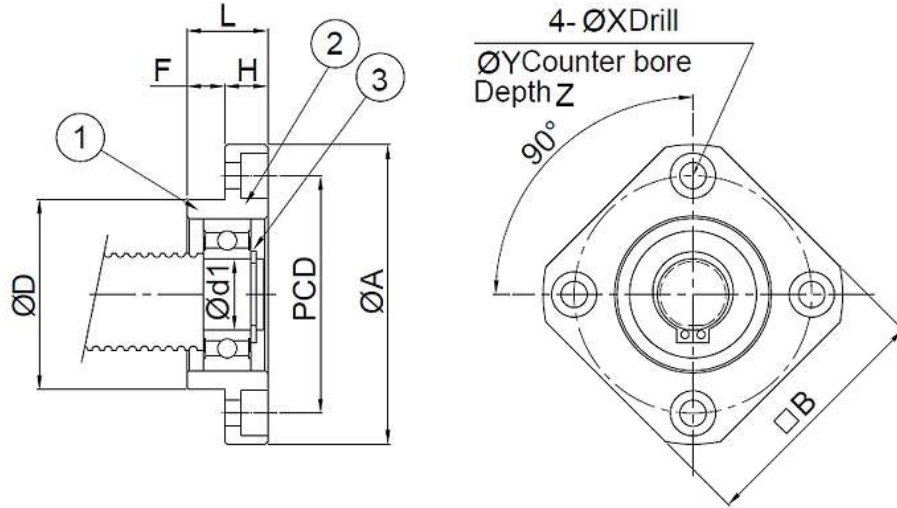

Part No.	Part name	Qty
1	Housing	1
2	Bearing	1
3	Snap ring	1



Specification	Main dimensions (mm)													Weight (kg)
	d1	L	H	F	D (Note 1)	A	PCD	B	X	Y	Z	Bearing	Snap ring	
FF06	6	10	6	4	22	36	28	28	3.4	6.5	4	606ZZ	S06	0.08
FF10	8	12	7	5	28	43	35	35	3.4	6.5	4	608ZZ	S08	0.1
FF12	10	15	7	8	34	52	42	42	4.5	8	4	6000ZZ	S10	0.15
FF15	15	17	9	8	40	63	50	52	5.5	9.5	5.5	6002ZZ	S15	0.22
FF17	17	20	11	9	50	77	62	61	6.6	11	6.5	6203ZZ	S17	0.35
FF20	20	20	11	9	57	85	70	68	6.6	11	6.5	6204ZZ	S20	0.45
FF25	25	24	14	10	63	98	80	79	9	14	8.5	6205ZZ	S25	0.66
FF30	30	27	18	9	75	117	95	93	11	17	11	6206ZZ	S30	1.05

Note: 1. Diameter tolerance [D] refer to the precision of standard bearing.

2. Specification are subject to change without notice.