

TIMKEN

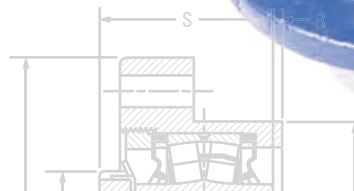

TIMKEN® SPHERICAL ROLLER BEARING SOLID-BLOCK HOUSED UNITS

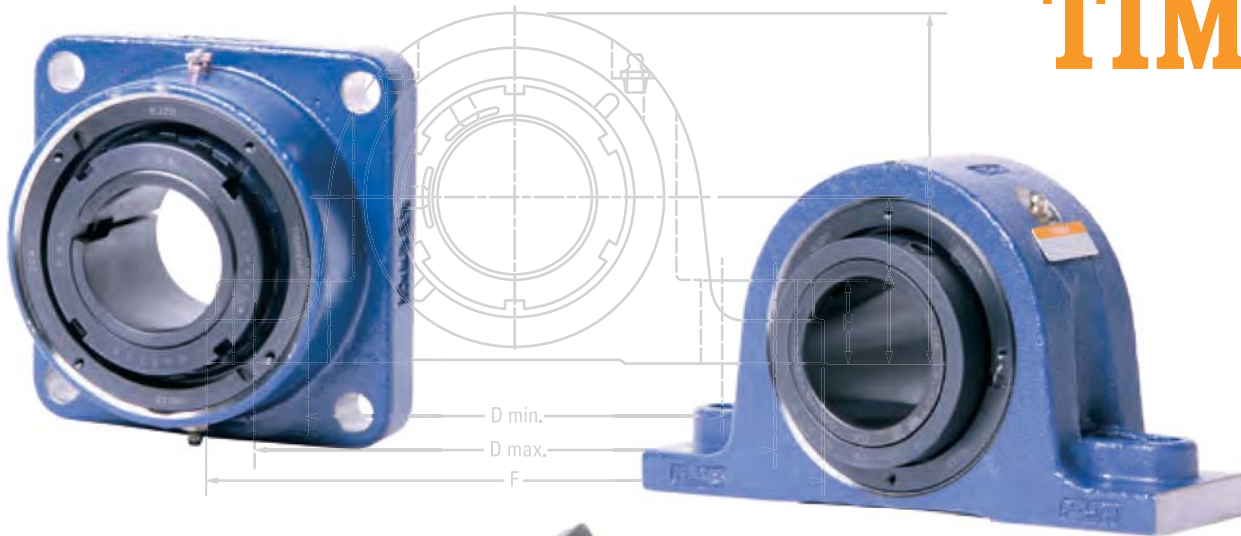
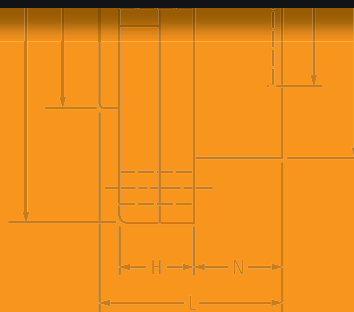
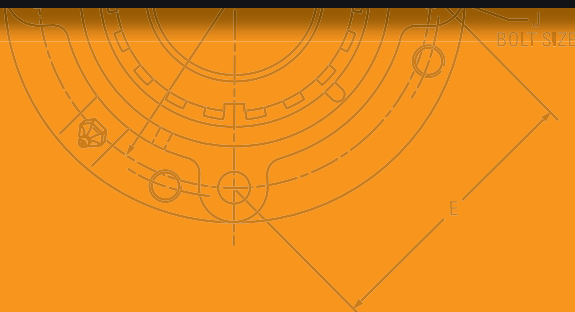

TIMKEN® SPHERICAL ROLLER BEARING SOLID-BLOCK HOUSED UNITS

OVERVIEW	2
INTRODUCTION	4
SHELF LIFE POLICY	10
ENGINEERING	
Bearing Load	14
Normal Speed Ratings for Seals	31
Seal Material Chemical Compatibility	34
Internal Radial Clearances	36
Shafting	38
Misalignment	39
Lubrication	39
Installation Guides	40
PRODUCT DATA TABLES	
Nomenclatures	60
Seal and Cover Options	65
V-Lock® Series (double taper lock)	80
CL Series (concentric [set screw] lock)	107
EC Series (eccentric lock)	137
TA/DV Series (tapered adapter lock)	161
Take-Up Frames	177



GROW STRONGER WITH TIMKEN

Every day, people around the world count on the strength of Timken. Our expertise in metallurgy, friction management and mechanical power transmission helps them accelerate improvements in productivity and uptime.

We supply products and services that can help keep your operations moving forward, whether you need drive train kits for commercial vehicles, durable housings for bearings in dirty environments, couplings that avoid metal-to-metal contact between motors and gearboxes, repair services for bearings and gearboxes, roller chain for dry, abrasive and high-moisture applications or other products and services for your applications.

When you choose Timken, you receive more than high-quality products and services: You gain a worldwide team of highly trained and experienced Timken people committed to working collaboratively with you to improve your business.

Globally, our 17,000 people provide reliable answers for a wide range of operations in manufacturing, mining, medical equipment, aerospace, transportation, oil and gas – and other diverse industries.



INCREASE YOUR EQUIPMENT UPTIME

In addition to high-quality bearings and mechanical power transmission components, we provide valuable integrated products and services. For example, we offer repair services and equipment monitoring equipment that can alert you to problems before they impact your uptime.

Additionally, we offer a broad selection of seals, premium lubricants, lubricators, couplings and chain to keep your operations moving smoothly.

Our 12 technology and engineering centers in the United States, Europe and Asia help pioneer tomorrow's innovations with extensive basic and applied scientific research programs. Through internal development and strategic acquisition of innovative companies, we continue to expand our portfolio of highly engineered bearings, power transmission products and advanced services.



INTRODUCTION

When your equipment faces harsh environments, you need roller bearing housed units that are rugged enough to withstand tough conditions and deliver exceptional performance.

You gain both with Timken® spherical roller bearing solid-block housed units.

Designed specifically to perform under extreme conditions, Timken solid-block housed units are able to handle up to ± 1.5 degrees of misalignment and withstand the impact of falling debris. Made of cast-steel housings and Timken® double-row spherical roller bearings, their unique sealing design offers protection from contaminants.

Increased performance and durability helps decrease the overall cost of ownership.

CUSTOMIZABLE DESIGN FEATURES TO FIT YOUR EQUIPMENT

With a full line of precision-made shaft-locking styles, seals and housings, it's easy to find the right housed unit to fit your application. Timken spherical roller bearing solid-block housed units interchange with a wide range of mounted roller bearings. Choose from many primary and secondary sealing mechanisms, and you decide how it's built without paying custom charges.

HOUSING STYLES

- Two-bolt pillow blocks.
- Four-bolt pillow blocks.
- Flange blocks.
- Piloted flanges.
- Cartridges.
- Take-up blocks.
- Cartridge units.

LOCKING STYLES

- Eccentric lock.
- Concentric lock (set screw) – single or double collar.
- Tapered adapter lock.
- V-Lock® double tapered lock – single or double nut.

DuPont™ is a trademark of E.I. du Pont de Nemours and Company.
Teflon® is a registered trademark of E.I. du Pont de Nemours and Company.
Dykor® is a registered trademark of Whitford Corporation.

SEALS

- Labyrinth seals – DuPont™ Teflon®:
 - High-speed applications.
 - Superior in dirty and wet conditions.
 - Able to operate at high temperatures.
 - Resistant to most chemicals.
 - Abrasion-resistant.
- Triple-lip seals – nitrile:
 - Self-purging.
 - Excellent in dirty and wet applications.
 - Chemical- and corrosion-resistant.
- Triple-lip seals – urethane:
 - All the benefits of nitrile, plus resistance to abrasion.

SECONDARY SEALS

- Closed-end covers.
- Open-end covers with:
 - Triple-lip seal.
 - DuPont Teflon.
 - V-ring seal.
- Piloted-flange cartridge backing plates with:
 - Triple-lip seal.
- Flange block backing plates with V-ring seal.

HOUSING COATINGS

- Powder coating – standard.
- Nickel plating – optional.
- Dykor® coating – optional.



Fig. 1. Two-bolt pillow block.



Fig. 2. Four-bolt pillow block.

OUTLASTING THE COMPETITION

Timken solid-block housed units last a long time, yet you don't pay extra for reliability. Experience an increase in performance and durability and a decrease in your overall cost of ownership when you use a Timken solid-block housed unit.

STANDS UP TO HARSH CONDITIONS

Protects Bearing. Harsh operating environments and lubrication issues often lead to housed unit bearing damage. Timken solid-block housed units multiply protection with primary and secondary seal options, as well as steel covers in sizes to fit these units. The space between the primary and secondary seals offers a fillable grease cavity for more protection.

Handles Misalignment. Without a properly aligned shaft, the life expectancy of most housed units decreases. However, Timken spherical roller bearing solid-block housed units run efficiently on misaligned shafts up to ± 1.5 degrees, thanks to their unique design and Timken spherical roller bearings.

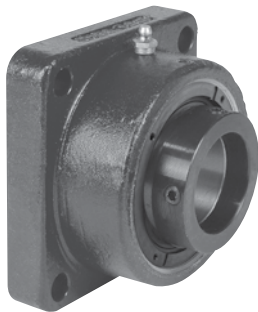

Fig. 3. Flange block.

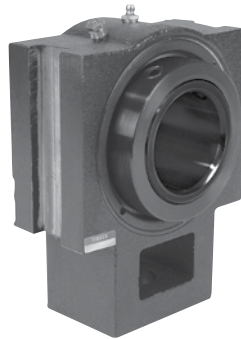

Fig. 4. Take-up block.



Fig. 5. Piloted-flange cartridge.



Fig. 6. Cartridge block.

INDUSTRIES AND APPLICATIONS

- Metal mills.
- Aggregate and cement.
- Mining.
- Power generation.
- Sawmills and other forest process industries.
- Pulp and paper.
- Material conveying.
- Commercial and industrial building equipment.
- Sugar mills.
- Agriculture.
- Waste management and water treatment.
- Off-highway and construction vehicles.
- HVAC, fans and blowers.
- Cranes, lifts and hoists.

DEPENDABLE SERVICE

Every Timken spherical roller bearing solid-block housed unit is backed by the service of our industry-leading experts who are ready to assist you with product design, application knowledge and field engineering support—anything you need to help improve uptime and maximize equipment performance.

LOCKING STYLES

V-LOCK® (DOUBLE-TAPERED LOCK) U.S. PAT. NO. 7344313

The V-Lock locking mechanism is excellent in high-speed applications and designed to maximize shaft-holding power and minimize the time needed for installation and removal as compared to conventional locking mechanisms. With no need for feeler gages during installation, the V-Lock locking mechanism offers superior holding power and is designed to eliminate overtightening. Mechanical withdrawal is a feature of double-nut units.

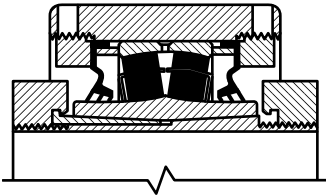

Fig. 7. V-Lock®.

CONCENTRIC LOCK (SET SCREW) – CL SERIES

Two set screws positioned at 60 degrees provide aggressive holding power. When configured with a double-collared insert, the bearing provides double the holding power compared to our standard single-collared insert.

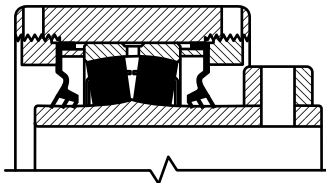

Fig. 8. Single set screw lock.

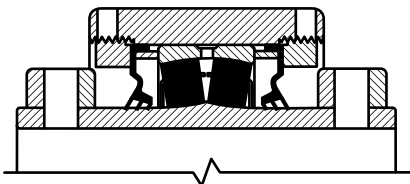

Fig. 9. Double set screw lock.

ECCENTRIC LOCK – EC SERIES

A reduced eccentric offset results in more mechanical advantage. This series provides a secure lock that should not release from a properly prepared shaft even in reversing applications.

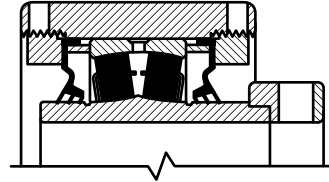

Fig. 10. Eccentric lock.

TAPERED ADAPTER LOCK – TA/DV SERIES

Excellent in high-load applications, this design uses a longer 2300-series adapter for increased shaft contact. This design offers the best shaft concentricity and highest capacity all while having the ability to accommodate undersized shafting.

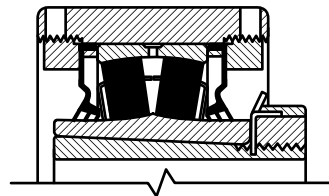

Fig. 11. Tapered adapter lock.

HOUSING COATINGS

POWDER COATING – STANDARD

All of our steel housings come powder-coated from the factory. Powder coating gives a hard finish that is tough and durable.

NICKEL PLATING – OPTIONAL

By nickel plating any of our housings, we are able to offer superior resistance to wear and corrosion.

DYKOR® COATING – OPTIONAL

Unaffected by most chemicals and solvents, Dykor coating is designed to last in harsh chemical environments while having extreme abrasion resistance.

Dykor® is a registered trademark of Whitford Corporation.

SOLID-BLOCK HOUSED UNIT BENEFITS

Depending on how you configure your bearing for a specific application, there's a wide range of product benefits.

- Multiple available sizes accommodate shaft diameters from 35 mm to 180 mm (1 7/16 in. to 7 in.).
- Efficient built-to-order manufacturing. Quick delivery of customized configurations for specific applications.
- Quicker installation. Machined feet, tapped puller holes, black oxide inner rings and multiple shaft-locking choices make it simpler to install this heavy-duty unit.
- Improved performance in high-contaminant environments. Wide selection of primary and secondary seals, as well as auxiliary covers.
- Bidirectional shaft expansion. Double-nut housing feature allows expansion in both directions.
- Increased uptime. Robust steel housing, a wide variety of seal choices and a high-performance Timken spherical roller bearing result in increased unit uptime.
- Increased shaft holding power and reduced shaft damage. Eccentric lock series is designed to stay tight in reversing applications on precision-ground shafts.
- Fewer misalignment issues. Bearings accept up to ± 1.5 degrees of misalignment.
- Protection against over-lubrication. Pressure relief valves come standard when unit is ordered with non-purgeable seals.
- Dimensionally interchanges with a wide range of other mounted roller bearing units.
- One-time shaft alignment on all housing unit styles. Machined feet ends allow for precise installation and blocking for faster future unit replacement.
- Easier removal with standard withdrawal holes on all piloted-flange units.
- Faster and easier changeover thanks to a comprehensive product offering that interchanges with virtually all solid-block roller bearing units.

SOLID-BLOCK HOUSED UNIT DESIGN

Flexibility through interchangeable components.

Double-row spherical roller bearing accepts misalignment.

Black oxide inner ring reduces shaft fretting corrosion.

Six primary seals in any combination:

- T seal standard labyrinth (DuPont™ Teflon®).
- M seal standard lip (nitrile rubber).
- N seal optional (DuPont™ Viton®).
- O seal optional (urethane).
- B seal optional (nitrile rubber).
- C seal optional (DuPont Viton).

Housing fit: J7, size-for-size to light interference.

Standard relief valve.

Optional bolt-on open and closed steel or urethane secondary seals.

Lubricated with premium industrial grease.

Machined feet aid in rapid installation and alignment.

Five shaft-locking styles:

- Single screw set.
- Double screw set.
- Eccentric.
- Tapered adapter.
- V-Lock®.

Easily converted to fixed or expansion in the field.

Housing can be supplied with powder (standard), nickel or Dykor® coatings.

Housing manufactured from 75000 psi tensile cast steel that retains the bearing-to-housing fit for those rough applications.

Fig. 12. High performance plus superior ruggedness.

DuPont™ is a trademark of E.I. du Pont de Nemours and Company.
Teflon® is a registered trademark of E.I. du Pont de Nemours and Company.
Viton® is a registered trademark of E.I. du Pont de Nemours and Company.
Dykor® is a registered trademark of Whitford Corporation.

HOW TO USE THIS CATALOG

We designed this catalog to help you find the Timken® spherical roller bearing solid-block housed units best suited to your specifications.

Timken offers an extensive range of bearings and accessories in both imperial and metric sizes. For your convenience, size ranges are indicated in millimeters and inches. Contact your Timken engineer to learn more about our complete line for the special needs of your application.

This publication contains dimensions, tolerances and load ratings, as well as engineering sections describing fitting practices for shafts and housings, internal clearances, materials and other bearing features. It provides valuable assistance in the initial consideration of the type and characteristics of the bearings that may best suit your particular needs.

ISO and ANSI/ABMA, as used in this publication, refer to the International Organization for Standardization and the American National Standards Institute/American Bearing Manufacturers Association.



SHELF LIFE AND STORAGE OF GREASE-LUBRICATED BEARINGS AND COMPONENTS

To help you get the most value from our products, Timken provides guidelines for the shelf life of grease-lubricated ball and roller bearings, components and assemblies. Shelf life information is based on Timken and industry test data and experience.

SHELF LIFE POLICY

Shelf life should be distinguished from lubricated bearing/component design life as follows:

- Shelf life of the grease-lubricated bearing/component represents the period of time prior to use or installation.
- The shelf life is a portion of the anticipated aggregate design life. It is impossible to accurately predict design life due to variations in lubricant bleed rates, oil migration, operating conditions, installation conditions, temperature, humidity and extended storage.
- Shelf life values, available from Timken, represent a maximum limit and assume adherence to the storage and handling guidelines suggested in this catalog or by a Timken associate. Deviations from the Timken storage and handling guidelines may reduce shelf life. Any specification or operating practice that defines a shorter shelf life should be used.

Timken cannot anticipate the performance of the grease lubricant after the bearing or component is installed or placed in service.

TIMKEN IS NOT RESPONSIBLE FOR THE SHELF LIFE OF ANY BEARING/COMPONENT LUBRICATED BY ANOTHER PARTY.

European REACH Compliance

Timken lubricants, greases and similar products sold in standalone containers or delivery systems are subject to the European REACH (**R**egistration, **E**valuation, **A**uthorization and **R**estriction of **C**hemicals) directive. For import into the European Union, Timken can sell and provide only those lubricants and greases that are registered with ECHA (**E**uropean **C**hemical **A**gency). For further information, please contact your Timken engineer.



STORAGE

Timken suggests the following storage guidelines for our finished products (bearings, components and assemblies, referred to as “products”):

- Unless directed otherwise by Timken, products should be kept in their original packaging until they are ready to be placed into service.
- Do not remove or alter any labels or stencil markings on the packaging.
- Products should be stored in such a way that the packaging is not pierced, crushed or otherwise damaged.
- After a product is removed from its packaging, it should be placed into service as soon as possible.
- When removing a product that is not individually packaged from a bulk pack container, the container should be resealed immediately after the product is removed.
- Do not use product that has exceeded its shelf life. Contact your local Timken engineer for further information on shelf life limits.
- The storage area temperature should be maintained between 0° C (32° F) and 40° C (104° F); temperature fluctuations should be minimized.
- The relative humidity should be maintained below 60 percent and the surfaces should be dry.
- The storage area should be kept free from airborne contaminants such as, but not limited to, dust, dirt, harmful vapors, etc.
- The storage area should be isolated from undue vibration.
- Extreme conditions of any kind should be avoided.

Due to the fact that Timken is not familiar with your particular storage conditions, we strongly suggest following these guidelines. However, you may be required by circumstances or applicable government requirements to adhere to stricter storage requirements.



Most bearing components typically ship protected with a corrosion-preventive compound that is not a lubricant. These components may be used in oil-lubricated applications without removal of the corrosion-preventive compound. When using some specialized grease lubrications, we advise you to remove the corrosion-preventive compound before packing the bearing components with suitable grease.

We pre-pack most housed unit types in this catalog with general-purpose grease suitable for their normal applications. It may be necessary for you to frequently replenish the grease for optimum performance.

Be careful in selecting lubrication, however, since different lubricants are often incompatible. You may order housed units pre-lubricated with a specified lubrication.

When you receive a bearing or housed unit shipment, do not remove products from their packaging until they are ready for mounting so they do not become corroded or contaminated.

Store bearings and housed units in an appropriate atmosphere so they remain protected for the intended period.

⚠ WARNING

Failure to observe the following warnings could create a risk of death or serious injury.

Proper maintenance and handling practices are critical. Always follow installation instructions and maintain proper lubrication.

Overheated bearings can ignite explosive atmospheres. Special care must be taken to properly select, install, maintain and lubricate housed unit bearings that are used in or near atmospheres that may contain explosive levels of combustible gases or accumulations of dust such as grain, coal, or other combustible materials. Consult your equipment designer or supplier for installation and maintenance instructions.

If hammer and bar are used for installation or removal of a part, use a mild steel bar (e.g., 1010 or 1020 grade). Mild steel bars are less likely to cause release of high speed fragments from the hammer or bar or the part being installed or removed.

CAUTION

Failure to follow these cautions may result in property damage.

Do not use damaged housed units.

NOTE

Do not use excessive force when mounting or dismounting the unit.

Follow all tolerance, fit, and torque recommendations.

Always follow the Original Equipment Manufacturer's installation and maintenance guidelines.

Ensure proper alignment.

Never weld housed units.

Do not heat components with an open flame.

Do not operate at bearing temperatures above 250° F (121° C).

NOTE

When converting a solid-block housed unit bearing from fixed to expansion, it is imperative that the unit that is going to be converted is correctly oriented. Since the insert in a steel housed unit flange bearing is held against either a shoulder or snap ring opposite the housing retaining nut, a flange bearing that has been converted to expansion can only float in the direction of the retaining nut. Based on this, the retaining nut must be on the side of the housing opposite the fixed bearing.

DISCLAIMER

This catalog is provided solely to give you analysis tools and data to assist you in your product selection. Product performance is affected by many factors beyond the control of Timken.

Therefore, the suitability and feasibility of all product selection must be validated by you.

Timken products are sold subject to Timken's terms and conditions of sale, which include its limited warranty and remedy, which terms may be found at www.timken.com/termsandconditionsofsale. Please consult with your Timken sales engineer for more information and assistance.

Every reasonable effort has been made to ensure the accuracy of the information in this writing, but no liability is accepted for errors, omissions or for any other reason.

COMPLIANCE

To view the complete engineering catalog, please visit www.timken.com. To order the catalog, please contact your Timken sales engineer and request a copy of the Timken Engineering Manual (order number 10424).

European REACH compliance Timken-branded lubricants, greases and similar products sold in stand-alone containers or delivery systems are subject to the European REACH (Registration, Evaluation, Authorization and Restriction of CHemicals) directive. For import into the European Union, Timken can sell and provide only those lubricants and greases that are registered with ECHA (European CHemical Agency). For further information, please contact your Timken sales engineer.

The Timken Company products shown in this catalog may be directly, or indirectly subject to a number of regulatory standards and directives originating from authorities in the USA, European Union, and around the world, including: REACH (EC 1907/2006, RoHS (2011/65/EU), ATEX (94/9/EC), 'CE' MARKING (93/68/EEC), CONFLICT MINERALS (Section 1502 of the Dodd-Frank Wall Street Reform and Consumer Protection Act).

For any questions or concerns regarding the compliancy or applicability of Timken products to these, or other unspecified standards, please contact your Timken sales engineer or customer services representative.

Updates are made periodically to this catalog. Visit www.timken.com for the most recent version of the Timken Spherical Roller Bearing Solid-Block Housed Units Catalog.

NOTE

When converting a solid-block housed unit from expansion to fixed on a mounted bearing, the locking-collar set screws must be released to allow the insert to move both in the housing and on the shaft.

ENGINEERING

The following topics are covered within this engineering section:

Bearing Load.....	14
Normal Speed Ratings for Seals.....	31
Seal Material Chemical Compatibility.....	34
Internal Radial Clearance.....	36
Shafting.....	38
Misalignment.....	39
Lubrication.....	39
Installation Guides.....	40

To view the complete engineering catalog, please visit www.timken.com. To order the catalog, please contact your Timken engineer and request a copy of the Timken Engineering Manual, order number 10424.

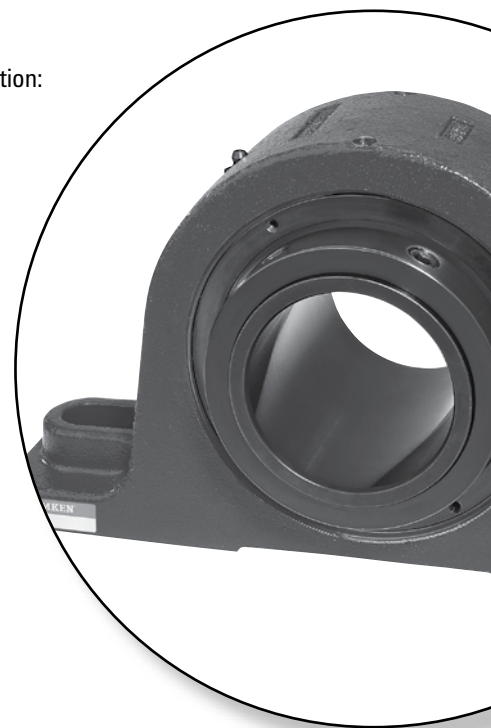

BEARING LOAD

Solid-block housed unit bearings are excellent for many applications including those with:

- Heavy radial loads.
- Heavy combined radial and thrust loads.
- Shock loads.
- Harsh contamination conditions.
- Low to moderate speeds.
- The possibility of misalignment.

Bearing loads generally come from one of three sources that should all be evaluated and considered when selecting steel housed unit bearings for your application. Contact your Timken engineer for assistance in determining specific application loads and for bearing recommendations.

- Static loads – weights of various components supported by the bearings.
- Drive loads – belts, chains or gears that exert forces on the shaft.
- Imposed loads – forces generated by equipment operation.

Generally, bearing loads are described as being radial (load perpendicular to the axis of the shaft) or axial (load parallel to the axis of the shaft). Axial loads also are referred to as thrust loads. Spherical roller bearings, by design, are very capable of accepting heavy radial loads, even when combined with a thrust load. Timken® Type E housed units are recommended for use in applications when only thrust loads are present or when the thrust component of the load is larger than the radial component.

To determine the allowable radial load at various RPMs for bearings supporting only radial loads, simply use the charts on pages 16 – 29. For bearings supporting both radial and thrust loads, an equivalent radial load must first be calculated prior to using these tables (see DYNAMIC EQUIVALENT RADIAL LOAD on page 15).

BELT LOADS

V-belt drives are common sources of drive loads. A good approximation of drive load may be calculated from the formula:

$$\text{Drive Load} = (\text{HP} \times 189000) / (\text{Pulley Diameter} \times \text{RPM})$$

$$\text{Drive Load} = (\text{KW} \times 189000) / (\text{Pulley Diameter} \times \text{RPM})$$

LOAD SHARING

In some cases, bearings may share the load unequally, depending on their position in relationship to the load. Use the appropriate formula below to determine the drive load on each bearing:

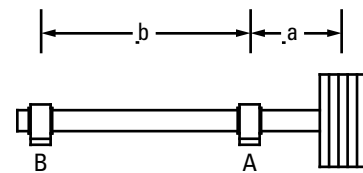

$$\text{Load A} = \text{Drive Load} \times (a + b) / b$$

$$\text{Load B} = \text{Drive Load} \times a / b$$

Fig. 13. Overhung load.

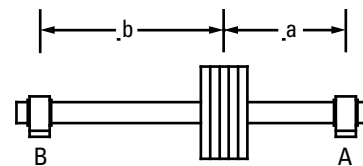

$$\text{Load A} = (\text{Drive Load} \times b) / (a + b)$$

$$\text{Load B} = (\text{Drive Load} \times a) / (a + b)$$

Fig. 14. Load between bearings.

DYNAMIC EQUIVALENT RADIAL LOAD

Bearings that support a combination of radial load and thrust load take an unequal load on one of the rows of rollers. The following formulas and bearing geometry factors are used to convert the independent thrust and radial loads into a single equivalent radial load. The calculated dynamic equivalent radial load (P_r) will have the same effect on bearing life (L_{10}) as a radial load of the same magnitude.

$$P_r = F_r + (Y1 \times F_a) \text{ when } F_a/F_r \leq e$$

$$P_r = (0.67 \times F_r) + (Y2 \times F_a) \text{ when } F_a/F_r > e$$

where:

P_r = Dynamic equivalent radial load

F_r = Applied radial load (lbs., N)

F_a = Applied thrust (axial) load (lbs., N)

$Y1$, $Y2$ and e are bearing geometry factors shown on pages 16 and 17.

BEARING CALCULATED LIFE

Customers select the bearing life of the bearings in equipment they are building. In the absence of a customer bearing life target, the following may be considered as a guideline:

- If the customer's machinery operates eight hours a day, then use a bearing life target of 20000 to 30000 hours.
- If the customer's machinery operates 24 hours a day, then use a bearing life target of 40000 to 60000 hours.

In addition, a service factor may be used where application conditions are harsh. Extreme environmental conditions or heavy shock or vibration will require the adjustment of load ratings before referring to the L_{10} tables. Please contact your Timken engineer for additional information.

Standard spherical roller bearing life calculation:

$$\text{Bearing life} = L_{10} = (C/P_r)^{10/3} \times (16667/\text{RPM})$$

where:

C = Dynamic capacity
(lbs., N)

P_r = Radial load/dynamic equivalent radial load

RPM = Revolutions per minute

DISCLAIMER

This catalog is provided solely to give you analysis tools and data to assist you in your product selection. Product performance is affected by many factors beyond the control of Timken. Therefore, the suitability and feasibility of all product selection must be validated by you.

TERMS AND CONDITIONS

Timken products are sold subject to our terms and conditions of sale, which include its limited warranty and remedy, which terms may be found at <http://www.timken.com/en-us/purchase/pages/termsandconditionsofsale.aspx>.

Please consult with your Timken engineer for more information and assistance.

A NOTE ON MINIMUM LOADS

In order for a spherical roller bearing to perform as designed, some radial load should be present. This is particularly true if the bearing is running at high speed. Although it is rarely an issue, as the existing static loads (weights of the combined supported components) usually provide an adequate radial load, there are times when it may be necessary to use a shaft diameter larger than the actual loads require. In these instances, the load becomes a small percentage of the bearing's capacity. Radial loads less than 4 percent of C should be avoided.

BEARING RADIAL AND THRUST FACTORS

TABLE 1. V-LOCK® SERIES (TAPERED BORE, C3)

Shaft Dia. mm in.	Bearing No.	Dynamic Capacity C kN lbs.	Static Capacity C ₀ kN lbs.	Equivalent Radial Load Factors		
				e	Y1	Y2
50 1 15/16, 2	22211	140 31400	142 31900	0.23	2.95	4.40
55 2 3/16, 2 1/4	22212	169 38100	174 39000	0.24	2.84	4.23
55 2 3/16, 2 1/4	22213	206 46400	216 48600	0.24	2.79	4.15
60, 65 2 7/16, 2 1/2	22214	213 47800	231 52000	0.23	2.90	4.32
60, 65 2 7/16, 2 1/2	22215	222 49900	240 54100	0.22	3.14	4.67
70, 75 2 11/16, 2 3/4, 2 15/16, 3	22216	254 57200	278 62500	0.22	3.14	4.67
70, 75 2 11/16, 2 3/4, 2 15/16, 3	22217	297 66900	320 71900	0.22	3.07	4.57
80, 85, 90 3 3/16, 3 1/4, 3 7/16, 3 1/2	22219	385 86600	441 99000	0.23	2.88	4.29
80, 85, 90 3 3/16, 3 1/4, 3 7/16, 3 1/2	22220	435 97700	502 113000	0.24	2.85	4.24
100 3 11/16, 3 3/4, 3 15/16, 4	22222	555 125000	653 147000	0.25	2.73	4.06
110 —	22224	647 145000	772 174000	0.25	2.70	4.02
110, 115 4 7/16, 4 1/2	22226	757 170000	945 212000	0.26	2.62	3.90
125, 130 4 15/16, 5	22228	863 194000	1060 237000	0.25	2.67	3.98

TABLE 2. CL SERIES (STRAIGHT BORE, C NORMAL)

Shaft Dia. mm in.	Bearing No.	Dynamic Capacity C kN lbs.	Static Capacity C ₀ kN lbs.	Equivalent Radial Load Factors		
				e	Y1	Y2
35 1 7/16, 1 1/2	22208	104 23400	99.7 22400	0.27	2.47	3.67
40, 45 1 11/16, 1 3/4	22209	109 24500	108 24200	0.26	2.64	3.93
50 1 15/16, 2	22210	117 26300	118 26600	0.24	2.84	4.23
55 2 3/16, 2 1/4	22211	140 31400	142 31900	0.23	2.95	4.40
60, 65 2 7/16, 2 1/2	22213	206 46400	216 48600	0.24	2.79	4.15
70, 75 2 11/16, 2 3/4, 2 15/16, 3	22215	222 49900	240 54100	0.22	3.14	4.67
80, 85, 90 3 3/16, 3 1/4, 3 7/16, 3 1/2	22218	355 79700	388 87200	0.23	2.90	4.31
100 3 15/16, 4	22220	435 97700	502 113000	0.24	2.85	4.24
110, 115 4 7/16, 4 1/2	22222	555 125000	653 147000	0.25	2.73	4.06
125, 130 4 15/16, 5	22226	757 170000	945 212000	0.26	2.62	3.90

TABLE 3. EC SERIES (STRAIGHT BORE, C NORMAL)

Shaft Dia.	Bearing No.	Dynamic Capacity C	Static Capacity C ₀	Equivalent Radial Load Factors		
				e	Y1	Y2
mm in.		kN lbs.	kN lbs.			
35 1 7/16, 1 1/2	22208	104 23400	99.7 22400	0.27	2.47	3.67
40, 45 1 11/16, 1 3/4	22209	109 24500	108 24200	0.26	2.64	3.93
50 1 15/16, 2	22210	117 26300	118 26600	0.24	2.84	4.23
55 2 3/16, 2 1/4	22211	140 31400	142 31900	0.23	2.95	4.40
60, 65 2 7/16, 2 1/2	22213	206 46400	216 48600	0.24	2.79	4.15
70, 75 2 11/16, 2 3/4, 2 15/16, 3	22215	222 49900	240 54100	0.22	3.14	4.67
80, 85, 90 3 3/16, 3 1/4, 3 7/16, 3 1/2	22218	355 79700	388 87200	0.23	2.90	4.31
100 3 11/16, 3 3/4, 3 15/16, 4	22220	435 97700	502 113000	0.24	2.85	4.24
110, 115 4 7/16, 4 1/2	22222	555 125000	653 147000	0.25	2.73	4.06
125, 130 4 15/16, 5	22226	757 170000	945 212000	0.26	2.62	3.90
140, 150 5 7/16, 5 1/2, 5 15/16, 6	23230	1270 286000	1660 372000	0.32	2.08	3.10
170, 180 6 7/16, 6 1/2, 6 15/16, 7	23234	1660 373000	2200 494000	0.33	2.08	3.09

TABLE 4. TA/DV SERIES (TAPERED BORE, C3)

Shaft Dia.	Bearing No.	Dynamic Capacity C	Static Capacity C ₀	Equivalent Radial Load Factors		
				e	Y1	Y2
mm in.		kN lbs.	kN lbs.			
40 1 7/16, 1 1/2	22209	109 24500	108 24200	0.26	2.64	3.93
45 1 11/16, 1 3/4	22210	117 26300	118 26600	0.24	2.84	4.23
50 1 15/16, 2	22211	140 31400	142 31900	0.23	2.95	4.40
55 —	22212	169 38100	174 39000	0.24	2.84	4.23
60 2 3/16, 2 1/4	22213	206 46400	216 48600	0.24	2.79	4.15
65 2 7/16, 2 1/2	22215	222 49900	240 54100	0.22	3.14	4.67
70 2 11/16, 2 3/4	22216	254 57200	278 62500	0.22	3.14	4.67
75 2 15/16, 3	22217	297 66900	320 71900	0.22	3.07	4.57
80 3 3/16, 3 1/4	22218	355 79700	388 87200	0.23	2.90	4.31
85 —	22219	385 86600	441 99000	0.23	2.88	4.29
90 3 7/16, 3 1/2	22220	435 97700	502 113000	0.24	2.85	4.24
100 3 15/16, 4	22222	555 125000	653 147000	0.25	2.73	4.06
110 4 3/16, 4 1/4	22224	647 145000	772 174000	0.25	2.70	4.02
115 4 7/16, 4 1/2	22226	757 170000	945 212000	0.26	2.62	3.90
125 4 15/16, 5	22228	863 194000	1060 237000	0.25	2.67	3.98

LOAD RATINGS

TABLE 5. V-LOCK SERIES – ALLOWABLE RADIAL LOAD (kN/LBS.) AT VARIOUS RPM⁽¹⁾

Shaft Diameter	Bearing No.	C	L ₁₀ Life	Speed ⁽²⁾															
				RPM															
mm in.		kN lbs.		50	100	200	500	1000	1200	1500	1800	2100	2400	2700	3000	3200	3500 ⁽¹⁾		
50 1 15/16, 2	22211	140 31400	10000	50.3 11319	40.9 9194	33.2 7468	25.2 5673	20.5 4608	19.4 4362	18.1 4080	17.2 3863	16.4 3688	15.8 3543	15.2 3420	14.7 3314	14.5 3250	14.1 3164		
			30000	36.2 8141	29.4 6612	23.9 5371	18.1 4080	14.7 3314	14.0 3138	13.1 2934	12.4 2778	11.8 2653	11.3 2549	10.9 2460	10.6 2383	10.4 2338	10.4 2338	10.1 2276	
			40000	33.2 7468	27.0 6066	21.9 4927	16.6 3743	13.5 3040	12.8 2878	12.0 2692	11.3 2549	10.8 2433	10.4 2338	10.0 2257	9.7 2186	9.7 2186	9.7 2186	9.5 2144	9.3 2088
			60000	29.4 6612	23.9 5371	19.4 4362	14.7 3314	12.0 2692	11.3 2549	10.6 2383	10.0 2257	9.6 2155	9.2 2070	8.9 1998	8.6 1936	8.6 1936	8.4 1899	8.4 1899	8.2 1849
			100000	25.2 5673	20.5 4608	16.6 3743	12.6 2843	10.3 2309	9.7 2186	9.1 2045	8.6 1936	8.2 1849	7.9 1776	7.6 1714	7.4 1661	7.4 1661	7.2 1629	7.2 1629	7.1 1586
55 2 3/16, 2 1/4	22212	169 38100	10000	61.1 13734	49.6 11155	40.3 9061	30.6 6883	24.9 5591	23.5 5293	22.0 4951	20.8 4687	19.9 4475	19.1 4300	18.5 4150	17.9 4021	17.5 3944	17.1 3839		
			30000	43.9 9878	35.7 8023	29.0 6517	22.0 4951	17.9 4021	16.9 3807	15.8 3561	15.0 3371	14.3 3219	13.8 3092	13.3 2985	12.9 2892	12.6 2837	12.6 2837	12.3 2761	
			40000	40.3 9061	32.7 7360	26.6 5978	20.2 4541	16.4 3689	15.5 3492	14.5 3266	13.8 3092	13.1 2953	12.6 2837	12.2 2738	11.8 2653	11.8 2653	11.6 2602	11.6 2602	11.3 2533
			60000	35.7 8023	29.0 6517	23.5 5293	17.9 4021	14.5 3266	13.8 3092	12.9 2892	12.2 2738	11.6 2614	11.2 2512	10.8 2425	10.4 2349	10.4 2349	10.2 2304	10.2 2304	10.0 2243
			100000	30.6 6883	24.9 5591	20.2 4541	15.3 3450	12.5 2802	11.8 2653	11.0 2481	10.4 2349	10.0 2243	9.6 2155	9.3 2080	9.0 2015	9.0 2015	8.8 1977	8.8 1977	8.6 1924
55 2 3/16, 2 1/4	22213	206 46400	10000	74.4 16726	60.4 13585	49.1 11035	37.3 8383	30.3 6809	28.7 6446	26.8 6029	25.4 5708	24.2 5450	23.3 5236	22.5 5054	21.8 4897	21.4 4803	20.8 4676		
			30000	53.5 12030	43.5 9771	35.3 7937	26.8 6029	21.8 4897	20.6 4636	19.3 4336	18.3 4105	17.4 3920	16.8 3766	16.2 3635	15.7 3522	15.4 3455	15.4 3455	15.0 3363	
			40000	49.1 11035	39.9 8963	32.4 7280	24.6 5531	20.0 4492	18.9 4253	17.7 3978	16.8 3766	16.0 3596	15.4 3455	14.8 3335	14.4 3231	14.4 3231	14.1 3169	14.1 3169	13.7 3085
			60000	43.5 9771	35.3 7937	28.7 6446	21.8 4897	17.7 3978	16.8 3766	15.7 3522	14.8 3335	14.2 3184	13.6 3059	13.1 2953	12.7 2861	12.7 2861	12.5 2806	12.5 2806	12.2 2732
			100000	37.3 8383	30.3 6809	24.6 5531	18.7 4201	15.2 3413	14.4 3231	13.4 3022	12.7 2861	12.2 2732	11.7 2624	11.3 2533	10.9 2454	10.9 2454	10.7 2407	10.7 2407	10.4 2343
60, 65 2 7/16, 2 1/2	22214	213 47800	10000	76.6 17230	62.3 13995	50.6 11368	38.4 8636	31.2 7014	29.5 6641	27.6 6211	26.2 5880	25.0 5615	24.0 5394	23.2 5207	22.4 5045	22.0 4948			
			30000	55.1 12392	44.8 10066	36.4 8176	27.6 6211	22.4 5045	21.2 4776	19.9 4467	18.8 4229	18.0 4038	17.3 3880	16.7 3745	16.1 3628	16.1 3628	15.8 3559		
			40000	50.6 11368	41.1 9234	33.4 7500	25.3 5697	20.6 4628	19.5 4381	18.2 4098	17.3 3880	16.5 3704	15.8 3559	15.3 3435	14.8 3328	14.8 3328	14.5 3265		
			60000	44.8 10066	36.4 8176	29.5 6641	22.4 5045	18.2 4098	17.3 3880	16.1 3628	15.3 3435	14.6 3280	14.0 3151	13.5 3042	13.1 2947	13.1 2947	12.9 2891		
			100000	38.4 8636	31.2 7014	25.3 5697	19.3 4328	15.6 3515	14.8 3328	13.8 3113	13.1 2947	12.5 2814	12.0 2703	11.6 2610	11.2 2528	11.2 2528	11.0 2480		

⁽¹⁾Speeds referenced here may be higher than speed rating for seals. Please refer to the charts on pages 31 – 32.

⁽²⁾For speeds greater than thermal reference speed, contact your Timken engineer.

Continued on next page.

Continued from previous page.

Shaft Diameter	Bearing No.	C	L ₁₀ Life	Speed ⁽²⁾														
				RPM														
mm in.		kN lbs.		50	100	200	500	1000	1200	1500	1800	2100	2400	2700 ⁽¹⁾	3000 ⁽¹⁾	3200 ⁽¹⁾		
60, 65 2 7/16, 2 1/2	22215	222 49900	10000	80.0 17987	65.0 14610	52.8 11867	40.1 9015	32.6 7322	30.8 6933	28.8 6484	27.3 6139	26.1 5861	25.0 5631	24.2 5436	23.4 5266	23.0 5166		
			30000	57.5 12937	46.7 10508	38.0 8535	28.8 6484	23.4 5266	22.2 4986	20.7 4663	19.6 4415	18.8 4216	18.0 4050	17.4 3909	16.8 3788	16.5 3715		
			40000	52.8 11867	42.9 9639	34.8 7829	26.5 5948	21.5 4831	20.3 4574	19.0 4278	18.0 4050	17.2 3867	16.5 3715	16.0 3586	15.5 3475	15.2 3408		
			60000	46.7 10508	38.0 8535	30.8 6933	23.4 5266	19.0 4278	18.0 4050	16.8 3788	16.0 3586	15.2 3424	14.6 3290	14.1 3175	13.7 3077	13.4 3018		
			100000	40.1 9015	32.6 7322	26.5 5948	20.1 4518	16.3 3670	15.5 3475	14.5 3250	13.7 3077	13.1 2938	12.6 2822	12.1 2724	11.7 2639	11.5 2589		
70, 75 2 11/16, 2 3/4, 2 15/16, 3	22216	254 57200	10000	91.7 20619	74.5 16748	60.5 13603	46.0 10334	37.3 8394	35.4 7947	33.1 7432	31.3 7037	29.9 6719	28.7 6455	27.7 6231	26.9 6037			
			30000	66.0 14829	53.6 12045	43.5 9784	33.1 7432	26.9 6037	25.4 5716	23.8 5346	22.5 5061	21.5 4832	20.7 4643	19.9 4481	19.3 4342			
			40000	60.5 13603	49.1 11049	39.9 8975	30.3 6818	24.6 5538	23.3 5243	21.8 4904	20.7 4643	19.7 4433	18.9 4259	18.3 4111	17.7 3983			
			60000	53.6 12045	43.5 9784	35.4 7947	26.9 6037	21.8 4904	20.7 4643	19.3 4342	18.3 4111	17.5 3925	16.8 3771	16.2 3640	15.7 3527			
			100000	46.0 10334	37.3 8394	30.3 6818	23.0 5179	18.7 4207	17.7 3983	16.6 3725	15.7 3527	15.0 3367	14.4 3235	13.9 3123	13.5 3026			
70, 75 2 11/16, 2 3/4, 2 15/16, 3	22217	297 66900	10000	107.3 24115	87.1 19588	70.8 15910	53.8 12086	43.7 9817	41.3 9295	38.7 8693	36.6 8230	35.0 7858	33.6 7550	32.4 7287				
			30000	77.1 17344	62.7 14088	50.9 11443	38.7 8693	31.4 7061	29.7 6685	27.8 6252	26.3 5919	25.1 5652	24.2 5430	23.3 5241				
			40000	70.8 15910	57.5 12923	46.7 10497	35.5 7974	28.8 6477	27.3 6132	25.5 5735	24.2 5430	23.1 5184	22.2 4981	21.4 4808	21.4 4808			
			60000	62.7 14088	50.9 11443	41.3 9295	31.4 7061	25.5 5735	24.2 5430	22.6 5078	21.4 4808	20.4 4591	19.6 4410	18.9 4257				
			100000	53.8 12086	43.7 9817	35.5 7974	26.9 6057	21.9 4920	20.7 4658	19.4 4357	18.3 4125	17.5 3938	16.8 3784	16.2 3652				
80, 85, 90 3 3/16, 3 1/4, 3 7/16, 3 1/2	22219	385 86600	10000	138.9 31216	112.8 25356	91.6 20595	69.6 15645	56.5 12708	53.5 12032	50.1 11252	47.4 10654	45.2 10172	43.5 9773	42.0 9433				
			30000	99.9 22452	81.1 18236	65.9 14813	50.1 11252	40.7 9140	38.5 8653	36.0 8093	34.1 7662	32.5 7316	31.3 7029	30.2 6785				
			40000	91.6 20595	74.4 16729	60.4 13588	45.9 10322	37.3 8384	35.3 7938	33.0 7424	31.3 7029	29.9 6711	28.7 6448	27.7 6224				
			60000	81.1 18236	65.9 14813	53.5 12032	40.7 9140	33.0 7424	31.3 7029	29.2 6574	27.7 6224	26.4 5942	25.4 5709	24.5 5511				
			100000	69.6 15645	56.5 12708	45.9 10322	34.9 7841	28.3 6369	26.8 6030	25.1 5640	23.7 5339	22.7 5098	21.8 4898	21.0 4728				

⁽¹⁾Speeds referenced here may be higher than speed rating for seals. Please refer to the charts on pages 31 – 32.

⁽²⁾For speeds greater than thermal reference speed, contact your Timken engineer.

Continued on next page.

LOAD RATINGS – continued

TABLE 5. V-LOCK SERIES – ALLOWABLE RADIAL LOAD (kN/LBS.) AT VARIOUS RPM⁽¹⁾

Shaft Diameter	Bearing No.	C	L ₁₀ Life	Speed ⁽²⁾										
				RPM										
mm in.		kN lbs.		50	100	200	500	1000	1200	1500	1800 ⁽¹⁾	2100 ⁽¹⁾	2400 ⁽¹⁾	2700 ⁽¹⁾
80, 85, 90 3 3/16, 3 1/4, 3 7/16, 3 1/2	22220	435 97700	10000	156.7 35218	127.2 28606	103.4 23235	78.5 17651	63.8 14337	60.4 13574	56.5 12695	53.5 12019	51.0 11476	49.0 11025	47.3 10642
			30000	112.7 25329	91.5 20574	74.3 16711	56.5 12695	45.9 10311	43.4 9762	40.6 9130	38.5 8644	36.7 8254	35.3 7930	34.0 7654
			40000	103.4 23235	84.0 18873	68.2 15329	51.8 11645	42.1 9459	39.8 8955	37.3 8375	35.3 7930	33.7 7571	32.4 7274	31.2 7021
			60000	91.5 20574	74.3 16711	60.4 13574	45.9 10311	37.3 8375	35.3 7930	33.0 7416	31.2 7021	29.8 6704	28.7 6441	27.7 6217
			100000	78.5 17651	63.8 14337	51.8 11645	39.3 8846	32.0 7185	30.3 6803	28.3 6362	26.8 6024	25.6 5752	24.6 5526	23.7 5334
100 3 11/16, 3 3/4, 3 15/16, 4	22222	555 125000	10000	200.4 45058	162.8 36599	132.2 29727	100.5 22583	81.6 18343	77.3 17367	72.2 16242	68.4 15377	65.3 14683	62.7 14106	
			30000	144.2 32407	117.1 26323	95.1 21381	72.2 16242	58.7 13193	55.6 12490	52.0 11682	49.2 11060	47.0 10560	45.1 10145	
			40000	132.2 29727	107.4 24146	87.2 19613	66.3 14899	53.8 12102	51.0 11458	47.7 10716	45.1 10145	43.1 9687	41.4 9306	
			60000	117.1 26323	95.1 21381	77.3 17367	58.7 13193	47.7 10716	45.1 10145	42.2 9488	40.0 8983	38.2 8577	36.7 8241	
			100000	100.5 22583	81.6 18343	66.3 14899	50.3 11318	40.9 9193	38.7 8704	36.2 8140	34.3 7707	32.7 7359	31.4 7070	
110 –	22224	647 145000	10000	232.5 52268	188.8 42455	153.4 34484	116.5 26196	94.6 21278	89.6 20145	83.8 18841	79.3 17838	75.8 17032	72.8 16363	
			30000	167.2 37592	135.8 30534	110.3 24802	83.8 18841	68.1 15303	64.5 14489	60.3 13551	57.1 12829	54.5 12250	52.4 11769	
			40000	153.4 34484	124.6 28010	101.2 22751	76.9 17283	62.4 14038	59.1 13291	55.3 12430	52.4 11769	50.0 11237	48.0 10796	
			60000	135.8 30534	110.3 24802	89.6 20145	68.1 15303	55.3 12430	52.4 11769	49.0 11007	46.4 10421	44.3 9950	42.5 9559	
			100000	116.5 26196	94.6 21278	76.9 17283	58.4 13129	47.4 10664	44.9 10097	42.0 9443	39.8 8940	38.0 8536	36.5 8201	

⁽¹⁾Speeds referenced here may be higher than speed rating for seals. Please refer to the charts on pages 31 – 32.

⁽²⁾For speeds greater than thermal reference speed, contact your Timken engineer.

Continued on next page.

Continued from previous page.

Shaft Diameter	Bearing No.	C	L ₁₀ Life	Speed ⁽²⁾									
				RPM									
mm in.		kN lbs.		50	100	200	500	1000	1200 ⁽¹⁾	1500 ⁽¹⁾	1800 ⁽¹⁾	2100 ⁽¹⁾	
110, 115 4 7/16, 4 1/2	22226	757 170000	10000	272.6 61279	221.4 49774	179.8 40429	136.6 30712	111.0 24946	105.1 23618	98.3 22089	93.0 20913	88.8 19968	
			30000	196.1 44074	159.2 35799	129.3 29078	98.3 22089	79.8 17942	75.6 16987	70.7 15887	66.9 15041	63.9 14362	
			40000	179.8 40429	146.1 32839	118.6 26673	90.1 20263	73.2 16458	69.3 15582	64.8 14573	61.4 13798	58.6 13174	
			60000	159.2 35799	129.3 29078	105.1 23618	79.8 17942	64.8 14573	61.4 13798	57.4 12904	54.3 12217	51.9 11665	
			100000	136.6 30712	111.0 24946	90.1 20263	68.5 15393	55.6 12503	52.7 11837	49.2 11071	46.6 10482	44.5 10008	
125, 130 4 15/16, 5	22228	863 194000	10000	311.1 69931	252.7 56801	205.2 46137	155.9 35048	126.6 28468	119.9 26953	112.1 25208	106.2 23866		
			30000	223.7 50296	181.7 40853	147.6 33183	112.1 25208	91.1 20475	86.2 19385	80.6 18130	76.4 17165		
			40000	205.2 46137	166.7 37475	135.4 30439	102.9 23123	83.5 18782	79.1 17782	74.0 16631	70.0 15746		
			60000	181.7 40853	147.6 33183	119.9 26953	91.1 20475	74.0 16631	70.0 15746	65.5 14726	62.0 13942		
			100000	155.9 35048	126.6 28468	102.9 23123	78.1 17566	63.5 14268	60.1 13508	56.2 12634	53.2 11961		

⁽¹⁾Speeds referenced here may be higher than speed rating for seals. Please refer to the charts on pages 31 – 32.

⁽²⁾For speeds greater than thermal reference speed, contact your Timken engineer.

LOAD RATINGS – continued

TABLE 6. CL SERIES – ALLOWABLE RADIAL LOAD (kN/LBS.) AT VARIOUS RPM⁽¹⁾

Shaft Diameter	Bearing No.	C	L ₁₀ Life	Speed ⁽²⁾													
				RPM													
mm in.		kN lbs.		50	100	200	500	1000	1200	1500	1800	2100	2400	2700	3000	3200	3500
35 1 7/16, 1 1/2	22208	104 23400	10000	37.5 8435	30.5 6851	24.8 5565	18.8 4227	15.3 3434	14.5 3251	13.5 3041	12.8 2879	12.2 2749	11.7 2641	11.3 2549	11.0 2470	10.8 2422	10.5 2358
			30000	27.0 6067	21.9 4928	17.8 4002	13.5 3041	11.0 2470	10.4 2338	9.7 2187	9.2 2070	8.8 1977	8.4 1899	8.2 1833	7.9 1776	7.7 1742	7.5 1696
			40000	24.8 5565	20.1 4520	16.3 3672	12.4 2789	10.1 2265	9.5 2145	8.9 2006	8.4 1899	8.1 1813	7.7 1742	7.5 1682	7.2 1629	7.1 1598	6.9 1556
			60000	21.9 4928	17.8 4002	14.5 3251	11.0 2470	8.9 2006	8.4 1899	7.9 1776	7.5 1682	7.1 1606	6.9 1543	6.6 1489	6.4 1443	6.3 1415	6.1 1378
			100000	18.8 4227	15.3 3434	12.4 2789	9.4 2119	7.7 1721	7.2 1629	6.8 1524	6.4 1443	6.1 1378	5.9 1323	5.7 1278	5.5 1238	5.4 1214	5.3 1182
40, 45 1 11/16, 1 3/4	22209	109 24500	10000	39.3 8831	31.9 7173	25.9 5827	19.7 4426	16.0 3595	15.1 3404	14.2 3183	13.4 3014	12.8 2878	12.3 2765	11.9 2669	11.5 2586	11.3 2536	11.0 2469
			30000	28.3 6352	22.9 5159	18.6 4191	14.2 3183	11.5 2586	10.9 2448	10.2 2290	9.6 2168	9.2 2070	8.8 1988	8.5 1919	8.3 1860	8.1 1824	7.9 1776
			40000	25.9 5827	21.1 4733	17.1 3844	13.0 2920	10.6 2372	10.0 2246	9.3 2100	8.8 1988	8.4 1899	8.1 1824	7.8 1761	7.6 1706	7.4 1673	7.2 1629
			60000	22.9 5159	18.6 4191	15.1 3404	11.5 2586	9.3 2100	8.8 1988	8.3 1860	7.8 1761	7.5 1681	7.2 1615	6.9 1559	6.7 1511	6.6 1482	6.4 1442
			100000	19.7 4426	16.0 3595	13.0 2920	9.9 2218	8.0 1802	7.6 1706	7.1 1595	6.7 1511	6.4 1442	6.2 1386	6.0 1338	5.8 1296	5.7 1271	5.5 1237
50 1 15/16, 2	22210	117 26300	10000	42.2 9480	34.3 7700	27.8 6255	21.1 4751	17.2 3859	16.3 3654	15.2 3417	14.4 3235	13.7 3089	13.2 2968	12.7 2865	12.3 2776	12.1 2723	11.8 2650
			30000	30.3 6818	24.6 5538	20.0 4498	15.2 3417	12.3 2776	11.7 2628	10.9 2458	10.4 2327	9.9 2222	9.5 2135	9.2 2060	8.9 1996	8.7 1958	8.5 1906
			40000	27.8 6255	22.6 5080	18.4 4127	13.9 3135	11.3 2546	10.7 2411	10.0 2255	9.5 2135	9.1 2038	8.7 1958	8.4 1890	8.1 1831	8.0 1796	7.8 1749
			60000	24.6 5538	20.0 4498	16.3 3654	12.3 2776	10.0 2255	9.5 2135	8.9 1996	8.4 1890	8.0 1805	7.7 1734	7.4 1674	7.2 1622	7.1 1590	6.9 1548
			100000	21.1 4751	17.2 3859	13.9 3135	10.6 2381	8.6 1934	8.1 1831	7.6 1713	7.2 1622	6.9 1548	6.6 1487	6.4 1436	6.2 1391	6.1 1364	5.9 1328
55 2 3/16, 2 1/4	22211	140 31400	10000	50.3 11319	40.9 9194	33.2 7468	25.2 5673	20.5 4608	19.4 4362	18.1 4080	17.2 3863	16.4 3688	15.8 3543	15.2 3420	14.7 3314	14.5 3250	14.1 3164
			30000	36.2 8141	29.4 6612	23.9 5371	18.1 4080	14.7 3314	14.0 3138	13.1 2934	12.4 2778	11.8 2653	11.3 2549	10.9 2460	10.6 2383	10.4 2338	10.1 2276
			40000	33.2 7468	27.0 6066	21.9 4927	16.6 3743	13.5 3040	12.8 2878	12.0 2692	11.3 2549	10.8 2433	10.4 2338	10.0 2257	9.7 2186	9.5 2144	9.3 2088
			60000	29.4 6612	23.9 5371	19.4 4362	14.7 3314	12.0 2692	11.3 2549	10.6 2383	10.0 2257	9.6 2155	9.2 2070	8.9 1998	8.6 1936	8.4 1899	8.2 1849
			100000	25.2 5673	20.5 4608	16.6 3743	12.6 2843	10.3 2309	9.7 2186	9.1 2045	8.6 1936	8.2 1849	7.9 1776	7.6 1714	7.4 1661	7.2 1629	7.1 1586
60, 65 2 7/16, 2 1/2	22213	206 46400	10000	74.4 16726	60.4 13585	49.1 11035	37.3 8383	30.3 6809	28.7 6446	26.8 6029	25.4 5708	24.2 5450	23.3 5236	22.5 5054	21.8 4897	21.4 4803	20.8 4676
			30000	53.5 12030	43.5 9771	35.3 7937	26.8 6029	21.8 4897	20.6 4636	19.3 4336	18.3 4105	17.4 3920	16.8 3766	16.2 3635	15.7 3522	15.4 3455	15.0 3363
			40000	49.1 11035	39.9 8963	32.4 7280	24.6 5531	20.0 4492	18.9 4253	17.7 3978	16.8 3766	16.0 3596	15.4 3455	14.8 3335	14.4 3231	14.1 3169	13.7 3085
			60000	43.5 9771	35.3 7937	28.7 6446	21.8 4897	17.7 3978	16.8 3766	15.7 3522	14.8 3335	14.2 3184	13.6 3059	13.1 2953	12.7 2861	12.5 2806	12.2 2732
			100000	37.3 8383	30.3 6809	24.6 5531	18.7 4201	15.2 3413	14.4 3231	13.4 3022	12.7 2861	12.2 2732	11.7 2624	11.3 2533	10.9 2454	10.7 2407	10.4 2343

⁽¹⁾Speeds referenced here may be higher than speed rating for seals. Please refer to the charts on pages 31 – 32.

⁽²⁾For speeds greater than thermal reference speed, contact your Timken engineer.

Continued on next page.

Continued from previous page.

Shaft Diameter	Bearing No.	C	L ₁₀ Life	Speed ⁽²⁾												
				RPM												
mm in.		kN lbs.		50	100	200	500	1000	1200	1500	1800	2100	2400	2700 ⁽¹⁾	3000 ⁽¹⁾	3200 ⁽¹⁾
70, 75 2 1/16, 2 3/4, 2 15/16, 3	22215	220 49900	10000	80.0 17987	65.0 14610	52.8 11867	40.1 9015	32.6 7322	30.8 6933	28.8 6484	27.3 6139	26.1 5861	25.0 5631	24.2 5436	23.4 5266	23.0 5166
			30000	57.5 12937	46.7 10508	38.0 8535	28.8 6484	23.4 5266	22.2 4986	20.7 4663	19.6 4415	18.8 4216	18.0 4050	17.4 3909	16.8 3788	16.5 3715
			40000	52.8 11867	42.9 9639	34.8 7829	26.5 5948	21.5 4831	20.3 4574	19.0 4278	18.0 4050	17.2 3867	16.5 3715	16.0 3586	15.5 3475	15.2 3408
			60000	46.7 10508	38.0 8535	30.8 6933	23.4 5266	19.0 4278	18.0 4050	16.8 3788	16.0 3586	15.2 3424	14.6 3290	14.1 3175	13.7 3077	13.4 3018
			100000	40.1 9015	32.6 7322	26.5 5948	20.1 4518	16.3 3670	15.5 3475	14.5 3250	13.7 3077	13.1 2938	12.6 2822	12.1 2724	11.7 2639	11.5 2589
80, 85, 90 3 3/16, 3 1/4, 3 7/16, 3 1/2	22218	355 79700	10000	127.8 28729	103.8 23335	84.3 18954	64.0 14399	52.0 11695	49.3 11073	46.1 10356	43.6 9805	41.6 9362	40.0 8994	38.6 8682		
			30000	91.9 20663	74.7 16783	60.6 13632	46.1 10356	37.4 8412	35.4 7964	33.1 7448	31.4 7052	29.9 6733	28.8 6469	27.8 6244		
			40000	84.3 18954	68.5 15396	55.6 12505	42.3 9500	34.3 7716	32.5 7305	30.4 6832	28.8 6469	27.5 6176	26.4 5934	25.5 5728		
			60000	74.7 16783	60.6 13632	49.3 11073	37.4 8412	30.4 6832	28.8 6469	26.9 6050	25.5 5728	24.3 5469	23.4 5254	22.6 5072		
			100000	64.0 14399	52.0 11695	42.3 9500	32.1 7216	26.1 5862	24.7 5550	23.1 5190	21.9 4914	20.9 4692	20.1 4508	19.4 4351		
100 3 15/16, 4	22220	435 97700	10000	156.7 35218	127.2 28606	103.4 23235	78.5 17651	63.8 14337	60.4 13574	56.5 12695	53.5 12019	51.0 11476	49.0 11025	47.3 10642		
			30000	112.7 25329	91.5 20574	74.3 16711	56.5 12695	45.9 10311	43.4 9762	40.6 9130	38.5 8644	36.7 8254	35.3 7930	34.0 7654		
			40000	103.4 23235	84.0 18873	68.2 15329	51.8 11645	42.1 9459	39.8 8955	37.3 8375	35.3 7930	33.7 7571	32.4 7274	31.2 7021		
			60000	91.5 20574	74.3 16711	60.4 13574	45.9 10311	37.3 8375	35.3 7930	33.0 7416	31.2 7021	29.8 6704	28.7 6441	27.7 6217		
			100000	78.5 17651	63.8 14337	51.8 11645	39.3 8846	32.0 7185	30.3 6803	28.3 6362	26.8 6024	25.6 5752	24.6 5526	23.7 5334		
110, 115 4 7/16, 4 1/2	22222	555 125000	10000	200.4 45058	162.8 36599	132.2 29727	100.5 22583	81.6 18343	77.3 17367	72.2 16242	68.4 15377	65.3 14683	62.7 14106			
			30000	144.2 32407	117.1 26323	95.1 21381	72.2 16242	58.7 13193	55.6 12490	52.0 11682	49.2 11060	47.0 10560	45.1 10145			
			40000	132.2 29727	107.4 24146	87.2 19613	66.3 14899	53.8 12102	51.0 11458	47.7 10716	45.1 10145	43.1 9687	41.4 9306			
			60000	117.1 26323	95.1 21381	77.3 17367	58.7 13193	47.7 10716	45.1 10145	42.2 9488	40.0 8983	38.2 8577	36.7 8241			
			100000	100.5 22583	81.6 18343	66.3 14899	50.3 11318	40.9 9193	38.7 8704	36.2 8140	34.3 7707	32.7 7359	31.4 7070			
125, 130 4 15/16, 5	22226	757 170000	10000	272.6 61279	221.4 49774	179.8 40429	136.6 30712	111.0 24946	105.1 23618	98.3 22089	93.0 20913	88.8 19968				
			30000	196.1 44074	159.2 35799	129.3 29078	98.3 22089	79.8 17942	75.6 16987	70.7 15887	66.9 15041	63.9 14362				
			40000	179.8 40429	146.1 32839	118.6 26673	90.1 20263	73.2 16458	69.3 15582	64.8 14573	61.4 13798	58.6 13174				
			60000	159.2 35799	129.3 29078	105.1 23618	79.8 17942	64.8 14573	61.4 13798	57.4 12904	54.3 12217	51.9 11665				
			100000	136.6 30712	111.0 24946	90.1 20263	68.5 15393	55.6 12503	52.7 11837	49.2 11071	46.6 10482	44.5 10008				

⁽¹⁾Speeds referenced here may be higher than speed rating for seals. Please refer to the charts on pages 31 – 32.

⁽²⁾For speeds greater than thermal reference speed, contact your Timken engineer.

LOAD RATINGS – continued

TABLE 7. EC SERIES – ALLOWABLE RADIAL LOAD (kN/LBS.) AT VARIOUS RPM⁽¹⁾

Shaft Diameter	Bearing No.	C	L ₁₀ Life	Speed ⁽²⁾													
				RPM													
mm in.		kN lbs.		50	100	200	500	1000	1200	1500	1800	2100	2400	2700	3000	3200	3500
35 1 1/16, 1 1/2	22208	104 23400	10000	37.5 8435	30.5 6851	24.8 5565	18.8 4227	15.3 3434	14.5 3251	13.5 3041	12.8 2879	12.2 2749	11.7 2641	11.3 2549	11.0 2470	10.8 2422	10.5 2358
			30000	27.0 6067	21.9 4928	17.8 4002	13.5 3041	11.0 2470	10.4 2338	9.7 2187	9.2 2070	8.8 1977	8.4 1899	8.2 1833	7.9 1776	7.7 1742	7.5 1696
			40000	24.8 5565	20.1 4520	16.3 3672	12.4 2789	10.1 2265	9.5 2145	8.9 2006	8.4 1899	8.1 1813	7.7 1742	7.5 1682	7.2 1629	7.1 1598	6.9 1556
			60000	21.9 4928	17.8 4002	14.5 3251	11.0 2470	8.9 2006	8.4 1899	7.9 1776	7.5 1682	7.1 1606	6.9 1543	6.6 1489	6.4 1443	6.3 1415	6.1 1378
			100000	18.8 4227	15.3 3434	12.4 2789	9.4 2119	7.7 1721	7.2 1629	6.8 1524	6.4 1443	6.1 1378	5.9 1323	5.7 1278	5.5 1238	5.4 1214	5.3 1182
40, 45 1 1/16, 1 3/4	22209	109 24500	10000	39.3 8831	31.9 7173	25.9 5827	19.7 4426	16.0 3595	15.1 3404	14.2 3183	13.4 3014	12.8 2878	12.3 2765	11.9 2669	11.5 2586	11.3 2536	11.0 2469
			30000	28.3 6352	22.9 5159	18.6 4191	14.2 3183	11.5 2586	10.9 2448	10.2 2290	9.6 2168	9.2 2070	8.8 1988	8.5 1919	8.3 1860	8.1 1824	7.9 1776
			40000	25.9 5827	21.1 4733	17.1 3844	13.0 2920	10.6 2372	10.0 2246	9.3 2100	8.8 1988	8.4 1899	8.1 1824	7.8 1761	7.6 1706	7.4 1673	7.2 1629
			60000	22.9 5159	18.6 4191	15.1 3404	11.5 2586	9.3 2100	8.8 1988	8.3 1860	7.8 1761	7.5 1681	7.2 1615	6.9 1559	6.7 1511	6.6 1482	6.4 1442
			100000	19.7 4426	16.0 3595	13.0 2920	9.9 2218	8.0 1802	7.6 1706	7.1 1595	6.7 1511	6.4 1442	6.2 1386	6.0 1338	5.8 1296	5.7 1271	5.5 1237
50 1 15/16, 2	22210	117 26300	10000	42.2 9480	34.3 7700	27.8 6255	21.1 4751	17.2 3859	16.3 3654	15.2 3417	14.4 3235	13.7 3089	13.2 2968	12.7 2865	12.3 2776	12.1 2723	11.8 2650
			30000	30.3 6818	24.6 5538	20.0 4498	15.2 3417	12.3 2776	11.7 2628	10.9 2458	10.4 2327	9.9 2222	9.5 2135	9.2 2060	8.9 1996	8.7 1958	8.5 1906
			40000	27.8 6255	22.6 5080	18.4 4127	13.9 3135	11.3 2546	10.7 2411	10.0 2255	9.5 2135	9.1 2038	8.7 1958	8.4 1890	8.1 1831	8.0 1796	7.8 1749
			60000	24.6 5538	20.0 4498	16.3 3654	12.3 2776	10.0 2255	9.5 2135	8.9 1996	8.4 1890	8.0 1805	7.7 1734	7.4 1674	7.2 1622	7.1 1590	6.9 1548
			100000	21.1 4751	17.2 3859	13.9 3135	10.6 2381	8.6 1934	8.1 1831	7.6 1713	7.2 1622	6.9 1548	6.6 1487	6.4 1436	6.2 1391	6.1 1364	5.9 1328
55 2 3/16, 2 1/4	22211	140 31400	10000	50.3 11319	40.9 9194	33.2 7468	25.2 5673	20.5 4608	19.4 4362	18.1 4080	17.2 3863	16.4 3688	15.8 3543	15.2 3420	14.7 3314	14.5 3250	14.1 3164
			30000	36.2 8141	29.4 6612	23.9 5371	18.1 4080	14.7 3314	14.0 3138	13.1 2934	12.4 2778	11.8 2653	11.3 2549	10.9 2460	10.6 2383	10.4 2338	10.1 2276
			40000	33.2 7468	27.0 6066	21.9 4927	16.6 3743	13.5 3040	12.8 2878	12.0 2692	11.3 2549	10.8 2433	10.4 2338	10.0 2257	9.7 2186	9.5 2144	9.3 2088
			60000	29.4 6612	23.9 5371	19.4 4362	14.7 3314	12.0 2692	11.3 2549	10.6 2383	10.0 2257	9.6 2155	9.2 2070	8.9 1998	8.6 1936	8.4 1899	8.2 1849
			100000	25.2 5673	20.5 4608	16.6 3743	12.6 2843	10.3 2309	9.7 2186	9.1 2045	8.6 1936	8.2 1849	7.9 1776	7.6 1714	7.4 1661	7.2 1629	7.1 1586
60, 65 2 7/16, 2 1/2	22213	206 46400	10000	74.4 16726	60.4 13585	49.1 11035	37.3 8383	30.3 6809	28.7 6446	26.8 6029	25.4 5708	24.2 5450	23.3 5236	22.5 5054	21.8 4897	21.4 4803	20.8 4676
			30000	53.5 12030	43.5 9771	35.3 7937	26.8 6029	21.8 4897	20.6 4636	19.3 4336	18.3 4105	17.4 3920	16.8 3766	16.2 3635	15.7 3522	15.4 3455	15.0 3363
			40000	49.1 11035	39.9 8963	32.4 7280	24.6 5531	20.0 4492	18.9 4253	17.7 3978	16.8 3766	16.0 3596	15.4 3455	14.8 3335	14.4 3231	14.1 3169	13.7 3085
			60000	43.5 9771	35.3 7937	28.7 6446	21.8 4897	17.7 3978	16.8 3766	15.7 3522	14.8 3335	14.2 3184	13.6 3059	13.1 2953	12.7 2861	12.5 2806	12.2 2732
			100000	37.3 8383	30.3 6809	24.6 5531	18.7 4201	15.2 3413	14.4 3231	13.4 3022	12.7 2861	12.2 2732	11.7 2624	11.3 2533	10.9 2454	10.7 2407	10.4 2343

⁽¹⁾Speeds referenced here may be higher than speed rating for seals. Please refer to the charts on pages 31 – 32.

⁽²⁾For speeds greater than thermal reference speed, contact your Timken engineer.

Continued on next page.

Continued from previous page.

Shaft Diameter	Bearing No.	C	L ₁₀ Life	Speed ⁽²⁾												
				RPM												
mm in.		kN lbs.		50	100	200	500	1000	1200	1500	1800	2100	2400	2700 ⁽¹⁾	3000 ⁽¹⁾	3200 ⁽¹⁾
70, 75 2 1/16, 2 3/4, 2 15/16, 3	22215	222 49900	10000	80.0 17987	65.0 14610	52.8 11867	40.1 9015	32.6 7322	30.8 6933	28.8 6484	27.3 6139	26.1 5861	25.0 5631	24.2 5436	23.4 5266	23.0 5166
			30000	57.5 12937	46.7 10508	38.0 8535	28.8 6484	23.4 5266	22.2 4986	20.7 4663	19.6 4415	18.8 4216	18.0 4050	17.4 3909	16.8 3788	16.5 3715
			40000	52.8 11867	42.9 9639	34.8 7829	26.5 5948	21.5 4831	20.3 4574	19.0 4278	18.0 4050	17.2 3867	16.5 3715	16.0 3586	15.5 3475	15.2 3408
			60000	46.7 10508	38.0 8535	30.8 6933	23.4 5266	19.0 4278	18.0 4050	16.8 3788	16.0 3586	15.2 3424	14.6 3290	14.1 3175	13.7 3077	13.4 3018
			100000	40.1 9015	32.6 7322	26.5 5948	20.1 4518	16.3 3670	15.5 3475	14.5 3250	13.7 3077	13.1 2938	12.6 2822	12.1 2724	11.7 2639	11.5 2589
80, 85, 90 3 3/16, 3 1/4, 3 7/16, 3 1/2	22218	355 79700	10000	127.8 28729	103.8 23335	84.3 18954	64.0 14399	52.0 11695	49.3 11073	46.1 10356	43.6 9805	41.6 9362	40.0 8994	38.6 8682		
			30000	91.9 20663	74.7 16783	60.6 13632	46.1 10356	37.4 8412	35.4 7964	33.1 7448	31.4 7052	29.9 6733	28.8 6469	27.8 6244		
			40000	84.3 18954	68.5 15396	55.6 12505	42.3 9500	34.3 7716	32.5 7305	30.4 6832	28.8 6469	27.5 6176	26.4 5934	25.5 5728		
			60000	74.7 16783	60.6 13632	49.3 11073	37.4 8412	30.4 6832	28.8 6469	26.9 6050	25.5 5728	24.3 5469	23.4 5254	22.6 5072		
			100000	64.0 14399	52.0 11695	42.3 9500	32.1 7216	26.1 5862	24.7 5550	23.1 5190	21.9 4914	20.9 4692	20.1 4508	19.4 4351		
100 3 11/16, 3 3/4, 3 15/16, 4	22220	435 97700	10000	156.7 35218	127.2 28606	103.4 23235	78.5 17651	63.8 14337	60.4 13574	56.5 12695	53.5 12019	51.0 11476	49.0 11025	47.3 10642		
			30000	112.7 25329	91.5 20574	74.3 16711	56.5 12695	45.9 10311	43.4 9762	40.6 9130	38.5 8644	36.7 8254	35.3 7930	34.0 7654		
			40000	103.4 23235	84.0 18873	68.2 15329	51.8 11645	42.1 9459	39.8 8955	37.3 8375	35.3 7930	33.7 7571	32.4 7274	31.2 7021		
			60000	91.5 20574	74.3 16711	60.4 13574	45.9 10311	37.3 8375	35.3 7930	33.0 7416	31.2 7021	29.8 6704	28.7 6441	27.7 6217		
			100000	78.5 17651	63.8 14337	51.8 11645	39.3 8846	32.0 7185	30.3 6803	28.3 6362	26.8 6024	25.6 5752	24.6 5526	23.7 5334		
110, 115 4 7/16, 4 1/2	22222	555 125000	10000	200.4 45058	162.8 36599	132.2 29727	100.5 22583	81.6 18343	77.3 17367	72.2 16242	68.4 15377	65.3 14683	62.7 14106			
			30000	144.2 32407	117.1 26323	95.1 21381	72.2 16242	58.7 13193	55.6 12490	52.0 11682	49.2 11060	47.0 10560	45.1 10145			
			40000	132.2 29727	107.4 24146	87.2 19613	66.3 14899	53.8 12102	51.0 11458	47.7 10716	45.1 10145	43.1 9687	41.4 9306			
			60000	117.1 26323	95.1 21381	77.3 17367	58.7 13193	47.7 10716	45.1 10145	42.2 9488	40.0 8983	38.2 8577	36.7 8241			
			100000	100.5 22583	81.6 18343	66.3 14899	50.3 11318	40.9 9193	38.7 8704	36.2 8140	34.3 7707	32.7 7359	31.4 7070			
125, 130 4 15/16, 5	22226	757 170000	10000	272.6 61279	221.4 49774	179.8 40429	136.6 30712	111.0 24946	105.1 23618	98.3 22089	93.0 20913	88.8 19968				
			30000	196.1 44074	159.2 35799	129.3 29078	98.3 22089	79.8 17942	75.6 16987	70.7 15887	66.9 15041	63.9 14362				
			40000	179.8 40429	146.1 32839	118.6 26673	90.1 20263	73.2 16458	69.3 15582	64.8 14573	61.4 13798	58.6 13174				
			60000	159.2 35799	129.3 29078	105.1 23618	79.8 17942	64.8 14573	61.4 13798	57.4 12904	54.3 12217	51.9 11665				
			100000	136.6 30712	111.0 24946	90.1 20263	68.5 15393	55.6 12503	52.7 11837	49.2 11071	46.6 10482	44.5 10008				

⁽¹⁾Speeds referenced here may be higher than speed rating for seals. Please refer to the charts on pages 31 – 32.

⁽²⁾For speeds greater than thermal reference speed, contact your Timken engineer.

Continued on next page.

LOAD RATINGS – *continued*

TABLE 7. EC SERIES – ALLOWABLE RADIAL LOAD (kN/LBS.) AT VARIOUS RPM⁽¹⁾ – *continued*

Shaft Diameter	Bearing No.	C	L ₁₀ Life	Speed ⁽²⁾					
				RPM					
mm in.		kN lbs.		50	100	200	500	1000 ⁽¹⁾	1200 ⁽¹⁾
140, 150 5 7/16, 5 1/2, 5 15/16, 6	23230	1270 286000	10000	458.6 103094	372.5 83738	302.6 68016	229.8 51669	186.7 41968	176.8 39735
			30000	329.8 74147	267.9 60226	217.6 48919	165.3 37162	134.3 30185	127.1 28578
			40000	302.6 68016	245.8 55247	199.6 44874	151.6 34089	123.2 27689	116.6 26215
			60000	267.9 60226	217.6 48919	176.8 39735	134.3 30185	109.1 24518	103.3 23213
			100000	229.8 51669	186.7 41968	151.6 34089	115.2 25896	93.6 21034	88.6 19914
170, 180 6 7/16, 6 1/2, 6 15/16, 7	23234	1660 373000		50	100	200	500	1000 ⁽¹⁾	
			10000	598.1 134454	485.8 109211	394.6 88707	299.8 67387	243.5 54735	
			30000	430.2 96703	349.4 78547	283.8 63800	215.6 48466	175.1 39367	
			40000	394.6 88707	320.5 72052	260.3 58525	197.8 44459	160.6 36112	
			60000	349.4 78547	283.8 63800	230.5 51822	175.1 39367	142.2 31976	
			100000	299.8 67387	243.5 54735	197.8 44459	150.2 33773	122.0 27433	

⁽¹⁾Speeds referenced here may be higher than speed rating for seals. Please refer to the charts on pages 31 – 32.

⁽²⁾For speeds greater than thermal reference speed, contact your Timken engineer.

TABLE 8. TA/DV SERIES – ALLOWABLE RADIAL LOAD (kN/LBS.) AT VARIOUS RPM⁽¹⁾

Shaft Diameter	Bearing No.	C	L ₁₀ Life	Speed ⁽²⁾													
				RPM													
mm in.		kN lbs.		50	100	200	500	1000	1200	1500	1800	2100	2400	2700	3000	3200	3500
40 1 7/16, 1 1/2	22209	109 24500	10000	39.3 8831	31.9 7173	25.9 5827	19.7 4426	16.0 3595	15.1 3404	14.2 3183	13.4 3014	12.8 2878	12.3 2765	11.9 2669	11.5 2586	11.3 2536	11.0 2469
			30000	28.3 6352	22.9 5159	18.6 4191	14.2 3183	11.5 2586	10.9 2448	10.2 2290	9.6 2168	9.2 2070	8.8 1988	8.5 1919	8.3 1860	8.1 1824	7.9 1776
			40000	25.9 5827	21.1 4733	17.1 3844	13.0 2920	10.6 2372	10.0 2246	9.3 2100	8.8 1988	8.4 1899	8.1 1824	7.8 1761	7.6 1706	7.4 1673	7.2 1629
			60000	22.9 5159	18.6 4191	15.1 3404	11.5 2586	9.3 2100	8.8 1988	8.3 1860	7.8 1761	7.5 1681	7.2 1615	6.9 1559	6.7 1511	6.6 1482	6.4 1442
			100000	19.7 4426	16.0 3595	13.0 2920	9.9 2218	8.0 1802	7.6 1706	7.1 1595	6.7 1511	6.4 1442	6.2 1386	6.0 1338	5.8 1296	5.7 1271	5.5 1237
45 1 11/16, 1 3/4	22210	117 26300	10000	42.2 9480	34.3 7700	27.8 6255	21.1 4751	17.2 3859	16.3 3654	15.2 3417	14.4 3235	13.7 3089	13.2 2968	12.7 2865	12.3 2776	12.1 2723	11.8 2650
			30000	30.3 6818	24.6 5538	20.0 4498	15.2 3417	12.3 2776	11.7 2628	10.9 2458	10.4 2327	9.9 2222	9.5 2135	9.2 2060	8.9 1996	8.7 1958	8.5 1906
			40000	27.8 6255	22.6 5080	18.4 4127	13.9 3135	11.3 2546	10.7 2411	10.0 2255	9.5 2135	9.1 2038	8.7 1958	8.4 1890	8.1 1831	8.0 1796	7.8 1749
			60000	24.6 5538	20.0 4498	16.3 3654	12.3 2776	10.0 2255	9.5 2135	8.9 1996	8.4 1890	8.0 1805	7.7 1734	7.4 1674	7.2 1622	7.1 1590	6.9 1548
			100000	21.1 4751	17.2 3859	13.9 3135	10.6 2381	8.6 1934	8.1 1831	7.6 1713	7.2 1622	6.9 1548	6.6 1487	6.4 1436	6.2 1391	6.1 1364	5.9 1328
50 1 15/16, 2	22211	140 31400	10000	50.3 11319	40.9 9194	33.2 7468	25.2 5673	20.5 4608	19.4 4362	18.1 4080	17.2 3863	16.4 3688	15.8 3543	15.2 3420	14.7 3314	14.5 3250	14.1 3164
			30000	36.2 8141	29.4 6612	23.9 5371	18.1 4080	14.7 3314	14.0 3138	13.1 2934	12.4 2778	11.8 2653	11.3 2549	10.9 2460	10.6 2383	10.4 2338	10.1 2276
			40000	33.2 7468	27.0 6066	21.9 4927	16.6 3743	13.5 3040	12.8 2878	12.0 2692	11.3 2549	10.8 2433	10.4 2338	10.0 2257	9.7 2186	9.5 2144	9.3 2088
			60000	29.4 6612	23.9 5371	19.4 4362	14.7 3314	12.0 2692	11.3 2549	10.6 2383	10.0 2257	9.6 2155	9.2 2070	8.9 1998	8.6 1936	8.4 1899	8.2 1849
			100000	25.2 5673	20.5 4608	16.6 3743	12.6 2843	10.3 2309	9.7 2186	9.1 2045	8.6 1936	8.2 1849	7.9 1776	7.6 1714	7.4 1661	7.2 1629	7.1 1586
55 –	22212	169 38100	10000	61.1 13734	49.6 11155	40.3 9061	30.6 6883	24.9 5591	23.5 5293	22.0 4951	20.8 4687	19.9 4475	19.1 4300	18.5 4150	17.9 4021	17.5 3944	17.1 3839
			30000	43.9 9878	35.7 8023	29.0 6517	22.0 4951	17.9 4021	16.9 3807	15.8 3561	15.0 3371	14.3 3219	13.8 3092	13.3 2985	12.9 2892	12.6 2837	12.3 2761
			40000	40.3 9061	32.7 7360	26.6 5978	20.2 4541	16.4 3689	15.5 3492	14.5 3266	13.8 3092	13.1 2953	12.6 2837	12.2 2738	11.8 2653	11.6 2602	11.3 2533
			60000	35.7 8023	29.0 6517	23.5 5293	17.9 4021	14.5 3266	13.8 3092	12.9 2892	12.2 2738	11.6 2614	11.2 2512	10.8 2425	10.4 2349	10.2 2304	10.0 2243
			100000	30.6 6883	24.9 5591	20.2 4541	15.3 3450	12.5 2802	11.8 2653	11.0 2481	10.4 2349	10.0 2243	9.6 2155	9.3 2080	9.0 2015	8.8 1977	8.6 1924
60 2 3/16, 2 1/4	22213	206 46400	10000	74.4 16726	60.4 13585	49.1 11035	37.3 8383	30.3 6809	28.7 6446	26.8 6029	25.4 5708	24.2 5450	23.3 5236	22.5 5054	21.8 4897	21.4 4803	20.8 4676
			30000	53.5 12030	43.5 9771	35.3 7937	26.8 6029	21.8 4897	20.6 4636	19.3 4336	18.3 4105	17.4 3920	16.8 3766	16.2 3635	15.7 3522	15.4 3455	15.0 3363
			40000	49.1 11035	39.9 8963	32.4 7280	24.6 5531	20.0 4492	18.9 4253	17.7 3978	16.8 3766	16.0 3596	15.4 3455	14.8 3335	14.4 3231	14.1 3169	13.7 3085
			60000	43.5 9771	35.3 7937	28.7 6446	21.8 4897	17.7 3978	16.8 3766	15.7 3522	14.8 3335	14.2 3184	13.6 3059	13.1 2953	12.7 2861	12.5 2806	12.2 2732
			100000	37.3 8383	30.3 6809	24.6 5531	18.7 4201	15.2 3413	14.4 3231	13.4 3022	12.7 2861	12.2 2732	11.7 2624	11.3 2533	10.9 2454	10.7 2407	10.4 2343

⁽¹⁾Speeds referenced here may be higher than speed rating for seals. Please refer to the charts on pages 31 – 32.

⁽²⁾For speeds greater than thermal reference speed, contact your Timken engineer.

Continued on next page.

LOAD RATINGS – continued

TABLE 8. TA/DV SERIES – ALLOWABLE RADIAL LOAD (kN/LBS.) AT VARIOUS RPM⁽¹⁾ – continued

Shaft Diameter	Bearing No.	C	L ₁₀ Life	Speed ⁽²⁾												
				RPM												
mm in.		kN lbs.		50	100	200	500	1000	1200	1500	1800	2100	2400	2700 ⁽¹⁾	3000 ⁽¹⁾	3200 ⁽¹⁾
65 2 7/16, 2 1/2	22215	222 49900	10000	80.0 17987	65.0 14610	52.8 11867	40.1 9015	32.6 7322	30.8 6933	28.8 6484	27.3 6139	26.1 5861	25.0 5631	24.2 5436	23.4 5266	23.0 5166
			30000	57.5 12937	46.7 10508	38.0 8535	28.8 6484	23.4 5266	22.2 4986	20.7 4663	19.6 4415	18.8 4216	18.0 4050	17.4 3909	16.8 3788	16.5 3715
			40000	52.8 11867	42.9 9639	34.8 7829	26.5 5948	21.5 4831	20.3 4574	19.0 4278	18.0 4050	17.2 3867	16.5 3715	16.0 3586	15.5 3475	15.2 3408
			60000	46.7 10508	38.0 8535	30.8 6933	23.4 5266	19.0 4278	18.0 4050	16.8 3788	16.0 3586	15.2 3424	14.6 3290	14.1 3175	13.7 3077	13.4 3018
			100000	40.1 9015	32.6 7322	26.5 5948	20.1 4518	16.3 3670	15.5 3475	14.5 3250	13.7 3077	13.1 2938	12.6 2822	12.1 2724	11.7 2639	11.5 2589
70 2 11/16, 2 3/4	22216	254 57200	10000	91.7 20619	74.5 16748	60.5 13603	46.0 10334	37.3 8394	35.4 7947	33.1 7432	31.3 7037	29.9 6719	28.7 6455	27.7 6231	26.9 6037	
			30000	66.0 14829	53.6 12045	43.5 9784	33.1 7432	26.9 6037	25.4 5716	23.8 5346	22.5 5061	21.5 4832	20.7 4643	19.9 4481	19.3 4342	
			40000	60.5 13603	49.1 11049	39.9 8975	30.3 6818	24.6 5538	23.3 5243	21.8 4904	20.7 4643	19.7 4433	18.9 4259	18.3 4111	17.7 3983	
			60000	53.6 12045	43.5 9784	35.4 7947	26.9 6037	21.8 4904	20.7 4643	19.3 4342	18.3 4111	17.5 3925	16.8 3771	16.2 3640	15.7 3527	
			100000	46.0 10334	37.3 8394	30.3 6818	23.0 5179	18.7 4207	17.7 3983	16.6 3725	15.7 3527	15.0 3367	14.4 3235	13.9 3123	13.5 3026	
75 2 15/16, 3	22217	297 66900	10000	107.3 24115	87.1 19588	70.8 15910	53.8 12086	43.7 9817	41.3 9295	38.7 8693	36.6 8230	35.0 7858	33.6 7550	32.4 7287	31.4 7024	
			30000	77.1 17344	62.7 14088	50.9 11443	38.7 8693	31.4 7061	29.7 6685	27.8 6252	26.3 5919	25.1 5652	24.2 5430	23.3 5241		
			40000	70.8 15910	57.5 12923	46.7 10497	35.5 7974	28.8 6477	27.3 6132	25.5 5735	24.2 5430	23.1 5184	22.2 4981	21.4 4808		
			60000	62.7 14088	50.9 11443	41.3 9295	31.4 7061	25.5 5735	24.2 5430	22.6 5078	21.4 4808	20.4 4591	19.6 4410	18.9 4257		
			100000	53.8 12086	43.7 9817	35.5 7974	26.9 6057	21.9 4920	20.7 4658	19.4 4357	18.3 4125	17.5 3938	16.8 3784	16.2 3652		
80 3 3/16, 3 1/4	22218	355 79700	10000	127.8 28729	103.8 23335	84.3 18954	64.0 14399	52.0 11695	49.3 11073	46.1 10356	43.6 9805	41.6 9362	40.0 8994	38.6 8682		
			30000	91.9 20663	74.7 16783	60.6 13632	46.1 10356	37.4 8412	35.4 7964	33.1 7448	31.4 7052	29.9 6733	28.8 6469	27.8 6244		
			40000	84.3 18954	68.5 15396	55.6 12505	42.3 9500	34.3 7716	32.5 7305	30.4 6832	28.8 6469	27.5 6176	26.4 5934	25.5 5728		
			60000	74.7 16783	60.6 13632	49.3 11073	37.4 8412	30.4 6832	28.8 6469	26.9 6050	25.5 5728	24.3 5469	23.4 5254	22.6 5072		
			100000	64.0 14399	52.0 11695	42.3 9500	32.1 7216	26.1 5862	24.7 5550	23.1 5190	21.9 4914	20.9 4692	20.1 4508	19.4 4351		
85 –	22219	385 86600	10000	138.9 31216	112.8 25356	91.6 20595	69.6 15645	56.5 12708	53.5 12032	50.1 11252	47.4 10654	45.2 10172	43.5 9773	42.0 9433		
			30000	99.9 22452	81.1 18236	65.9 14813	50.1 11252	40.7 9140	38.5 8653	36.0 8093	34.1 7662	32.5 7316	31.3 7029	30.2 6785		
			40000	91.6 20595	74.4 16729	60.4 13588	45.9 10322	37.3 8384	35.3 7938	33.0 7424	31.3 7029	29.9 6711	28.7 6448	27.7 6224		
			60000	81.1 18236	65.9 14813	53.5 12032	40.7 9140	33.0 7424	31.3 7029	29.2 6574	27.7 6224	26.4 5942	25.4 5709	24.5 5511		
			100000	69.6 15645	56.5 12708	45.9 10322	34.9 7841	28.3 6369	26.8 6030	25.1 5640	23.7 5339	22.7 5098	21.8 4898	21.0 4728		

⁽¹⁾Speeds referenced here may be higher than speed rating for seals. Please refer to the charts on pages 31 – 32.

⁽²⁾For speeds greater than thermal reference speed, contact your Timken engineer.

Continued on next page.

Continued from previous page.

Shaft Diameter	Bearing No.	C	L ₁₀ Life	Speed ⁽²⁾											
				RPM											
mm in.		kN lbs.		50	100	200	500	1000	1200	1500	1800 ⁽¹⁾	2100 ⁽¹⁾	2400 ⁽¹⁾	2700 ⁽¹⁾	
90 3 7/16, 3 1/2	22220	435 97700	10000	156.7 35218	127.2 28606	103.4 23235	78.5 17651	63.8 14337	60.4 13574	56.5 12695	53.5 12019	51.0 11476	49.0 11025	47.3 10642	
			30000	112.7 25329	91.5 20574	74.3 16711	56.5 12695	45.9 10311	43.4 9762	40.6 9130	38.5 8644	36.7 8254	35.3 7930	34.0 7654	
			40000	103.4 23235	84.0 18873	68.2 15329	51.8 11645	42.1 9459	39.8 8955	37.3 8375	35.3 7930	33.3 7930	33.7 7571	32.4 7274	31.2 7021
			60000	91.5 20574	74.3 16711	60.4 13574	45.9 10311	37.3 8375	35.3 7930	33.0 7416	31.2 7021	29.8 6704	28.7 6441	27.7 6217	
			100000	78.5 17651	63.8 14337	51.8 11645	39.3 8846	32.0 7185	30.3 6803	28.3 6362	26.8 6024	25.6 5752	24.6 5526	23.7 5334	
						50	100	200	500	1000	1200	1500 ⁽¹⁾	1800 ⁽¹⁾	2100 ⁽¹⁾	2400 ⁽¹⁾
100 3 15/16, 4	22222	555 125000	10000	200.4 45058	162.8 36599	132.2 29727	100.5 22583	81.6 18343	77.3 17367	72.2 16242	68.4 15377	65.3 14683	62.7 14106		
			30000	144.2 32407	117.1 26323	95.1 21381	72.2 16242	58.7 13193	55.6 12490	52.0 11682	49.2 11060	47.0 10560	45.1 10145		
			40000	132.2 29727	107.4 24146	87.2 19613	66.3 14899	53.8 12102	51.0 11458	47.7 10716	45.1 10145	43.1 9687	41.4 9306		
			60000	117.1 26323	95.1 21381	77.3 17367	58.7 13193	47.7 10716	45.1 10145	42.2 9488	40.0 8983	38.2 8577	36.7 8241		
			100000	100.5 22583	81.6 18343	66.3 14899	50.3 11318	40.9 9193	38.7 8704	36.2 8140	34.3 7707	32.7 7359	31.4 7070		
						50	100	200	500	1000	1200	1500 ⁽¹⁾	1800 ⁽¹⁾	2100 ⁽¹⁾	2400 ⁽¹⁾
110 4 3/16, 4 1/4	22224	647 145000	10000	232.5 52268	188.8 42455	153.4 34484	116.5 26196	94.6 21278	89.6 20145	83.8 18841	79.3 17838	75.8 17032	72.8 16363		
			30000	167.2 37592	135.8 30534	110.3 24802	83.8 18841	68.1 15303	64.5 14489	60.3 13551	57.1 12829	54.5 12250	52.4 11769		
			40000	153.4 34484	124.6 28010	101.2 22751	76.9 17283	62.4 14038	59.1 13291	55.3 12430	52.4 11769	50.0 11237	48.0 10796		
			60000	135.8 30534	110.3 24802	89.6 20145	68.1 15303	55.3 12430	52.4 11769	49.0 11007	46.4 10421	44.3 9950	42.5 9559		
			100000	116.5 26196	94.6 21278	76.9 17283	58.4 13129	47.4 10664	44.9 10097	42.0 9443	39.8 8940	38.0 8536	36.5 8201		
						50	100	200	500	1000	1200 ⁽¹⁾	1500 ⁽¹⁾	1800 ⁽¹⁾	2100 ⁽¹⁾	
115 4 7/16, 4 1/2	22226	757 170000	10000	272.6 61279	221.4 49774	179.8 40429	136.6 30712	111.0 24946	105.1 23618	98.3 22089	93.0 20913	88.8 19968			
			30000	196.1 44074	159.2 35799	129.3 29078	98.3 22089	79.8 17942	75.6 16987	70.7 15887	66.9 15041	63.9 14362			
			40000	179.8 40429	146.1 32839	118.6 26673	90.1 20263	73.2 16458	69.3 15582	64.8 14573	61.4 13798	58.6 13174			
			60000	159.2 35799	129.3 29078	105.1 23618	79.8 17942	64.8 14573	61.4 13798	57.4 12904	54.3 12217	51.9 11665			
			100000	136.6 30712	111.0 24946	90.1 20263	68.5 15393	55.6 12503	52.7 11837	49.2 11071	46.6 10482	44.5 10008			
						50	100	200	500	1000 ⁽¹⁾	1200 ⁽¹⁾	1500 ⁽¹⁾	1800 ⁽¹⁾		
125 4 15/16, 5	22228	863 194000	10000	311.1 69931	252.7 56801	205.2 46137	155.9 35048	126.6 28468	119.9 26953	112.1 25208	106.2 23866				
			30000	223.7 50296	181.7 40853	147.6 33183	112.1 25208	91.1 20475	86.2 19385	80.6 18130	76.4 17165				
			40000	205.2 46137	166.7 37475	135.4 30439	102.9 23123	83.5 18782	79.1 17782	74.0 16631	70.0 15746				
			60000	181.7 40853	147.6 33183	119.9 26953	91.1 20475	74.0 16631	70.0 15746	65.5 14726	62.0 13942				
			100000	155.9 35048	126.6 28468	102.9 23123	78.1 17566	63.5 14268	60.1 13508	56.2 12634	53.2 11961				
						50	100	200	500	1000 ⁽¹⁾	1200 ⁽¹⁾	1500 ⁽¹⁾	1800 ⁽¹⁾		

⁽¹⁾Speeds referenced here may be higher than speed rating for seals. Please refer to the charts on pages 31 – 32.

⁽²⁾For speeds greater than thermal reference speed, contact your Timken engineer.

HOUSING LOADS

Because solid-block housed units are made of cast steel, they are built to last with high allowable load limits in multiple orientations.

Refer to the table below for the maximum recommended housing load limit.

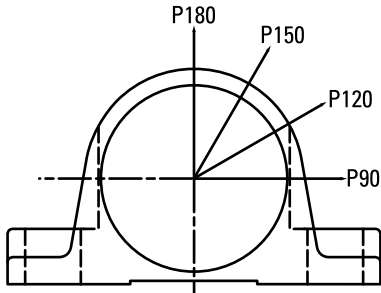

Fig. 15. Allowable housing loads.

CAUTION
Failure to follow these cautions could create a risk of injury.

Do not use damaged housed units. The use of a damaged housed unit can result in equipment damage and/or injury.

TABLE 9. HOUSING CAPACITY CHART (222XX SERIES)

QM, QA & TA SERIES			QV & DV SERIES		
Bearing No.	Maximum Recommended Housing Loads		Bearing No.	Maximum Recommended Housing Loads	
	2-bolt	4-bolt		2-bolt	4-bolt
	kN lbs.	kN lbs.		kN lbs.	kN lbs.
22208	109 24400	N/A	22208	N/A	N/A
22209	117 26400	N/A	22209	117 26400	N/A
22210	134 30200	N/A	22210	134 30200	N/A
22211	158 35400	158 35400	22211	158 35400	N/A
22212	174 39000	174 39000	22212	174 39000	N/A
22213	228 51300	235 52800	22213	228 51300	N/A
22214	N/A	N/A	22214	231 52000	231 52000
22215	266 59700	267 60000	22215	266 59700	N/A
22216	278 62500	278 62500	22216	278 62500	278 62500
22217	320 71900	320 71900	22217	320 71900	238 53500
22218	404 90700	425 95500	22218	N/A	N/A
22219	386 86800	433 97400	22219	394 88600	399 89700
22220	512 115000	512 115000	22220	512 115000	423 95000
22222	478 107400	677 152100	22222	677 152100	677 152100
22224	494 110900	547 123000	22224	N/A	N/A
22226	687 154300	837 188200	22226	837 188200	837 188200
22228	745 167500	N/A	22228	828 186000	576 129400
23230	1655 372000	1512 339700	23230	N/A	N/A
23234	N/A	2198 26400	23234	N/A	N/A

*The values listed above are the maximum recommend housing load ratings; these loads may exceed bearing, mounting bolt and/or shaft capacities.

**When side load is present stop bars or shear strips should be used against the machined housing foot ends.

NORMAL SPEED RATINGS FOR SEALS

TABLE 10. V-LOCK SERIES NORMAL SEAL SPEED RATINGS (RPM)

Shaft Dia.	Bearing No.	Oil Lubrication			Grease Lubrication		
		M/N Seal ⁽¹⁾	T Seal	B/C/O Seal ⁽¹⁾	M/N Seal ⁽¹⁾	T Seal	B/C/O Seal ⁽¹⁾
mm in.							
50 1 15/16, 2	22211	2200	3800	1800	2200	3200	1600
55 2 3/16, 2 1/4	22212	2000	3500	1650	2000	3000	1550
	22213	1800	3200	1500	1800	2800	1500
60, 65 2 7/16, 2 1/2	22214	1700	3050	1400	1700	2600	1400
	22215	1600	2900	1300	1600	2400	1300
70, 75 2 11/16, 2 3/4 2 15/16, 3	22216	1500	2650	1200	1500	2200	1150
	22217	1400	2400	1100	1400	2000	1100
80, 85, 90 3 3/16, 3 1/4 3 7/16, 3 1/2	22219	1300	2200	1000	1300	1800	950
	22220	1200	2000	900	1200	1600	900
100 3 11/16, 3 3/4 3 15/16, 4	22222	900	1700	600	900	1200	600
110, 115 4 7/16, 4 1/2	22224	700	1500	400	700	1000	400
	22226						
125, 130 4 15/16, 5	22228	650	1200	350	650	900	350

⁽¹⁾Bearings with contact seals will have higher operating temperatures than bearings with labyrinth seals.

TABLE 11. CL SERIES NORMAL SEAL SPEED RATINGS (RPM)

Shaft Dia.	Bearing No.	Oil Lubrication			Grease Lubrication		
		M/N Seal ⁽¹⁾	T Seal	B/C/O Seal ⁽¹⁾	M/N Seal ⁽¹⁾	T Seal	B/C/O Seal ⁽¹⁾
mm in.							
35 1 7/16, 1 1/2	22208	2700	4500	1950	2700	4000	1950
40, 45 1 11/16, 1 3/4	22209	2700	4500	1950	2700	4000	1950
50 1 15/16, 2	22210	2400	4200	1800	2400	3550	1800
55 2 3/16, 2 1/4	22211	2200	3800	1600	2200	3200	1600
60, 65 2 7/16, 2 1/2	22213	1800	3200	1500	1800	2800	1500
70, 75 2 11/16, 2 3/4 2 15/16, 3	22215	1600	2900	1300	1600	2400	1300
80, 85, 90 3 3/16, 3 1/4 3 7/16, 3 1/2	22218	1400	2400	1000	1400	2000	1000
100 3 15/16, 4	22220	1200	2000	900	1200	1600	900
110, 115 4 7/16, 4 1/2	22222	900	1700	600	900	1200	600
125, 130 4 15/16, 5	22226	700	1500	400	700	1000	400

⁽¹⁾Bearings with contact seals will have higher operating temperatures than bearings with labyrinth seals.

NORMAL SPEED RATINGS FOR SEALS

TABLE 12. EC SERIES NORMAL SEAL SPEED RATINGS (RPM)

Shaft Dia. mm in.	Bearing No.	Oil Lubrication			Grease Lubrication		
		M/N Seal ⁽¹⁾	T Seal	B/C/O Seal ⁽¹⁾	M/N Seal ⁽¹⁾	T Seal	B/C/O Seal ⁽¹⁾
35 1 7/16, 1 1/2	22208	2700	4500	1950	2700	4000	1950
40, 45 1 11/16, 1 3/4	22209	2700	4500	1950	2700	4000	1950
50 1 15/16, 2	22210	2400	4200	1800	2400	3550	1800
55 2 3/16, 2 1/4	22211	2200	3800	1600	2200	3200	1600
60, 65 2 7/16, 2 1/2	22213	1800	3200	1500	1800	2800	1500
70, 75 2 11/16, 2 3/4, 2 15/16, 3	22215	1600	2900	1300	1600	2400	1300
80, 85, 90 3 3/16, 3 1/4 3 7/16, 3 1/2	22218	1400	2400	1000	1400	2000	1000
100 3 11/16, 3 3/4 3 15/16, 4	22220	1200	2000	900	1200	1600	900
110, 115 4 7/16, 4 1/2	22222	900	1700	600	900	1200	600
125, 130 4 15/16, 5	22226	700	1500	400	700	1000	400
140, 150 5 7/16, 5 1/2 5 15/16, 6	23230	650	950	350	600	800	350
170, 180 6 7/16, 6 1/2 6 15/16, 7	23234	600	900	350	600	800	350

⁽¹⁾Bearings with contact seals will have higher operating temperatures than bearings with labyrinth seals.

TABLE 13. TA/DV SERIES NORMAL SEAL SPEED RATINGS (RPM)

Shaft Dia. mm in.	Bearing No.	Oil Lubrication			Grease Lubrication		
		M/N Seal ⁽¹⁾	T Seal	B/C/O Seal ⁽¹⁾	M/N Seal ⁽¹⁾	T Seal	B/C/O Seal ⁽¹⁾
40 1 7/16, 1 1/2	22209	2700	4500	1950	2700	4000	1950
45 1 11/16, 1 3/4	22210	2400	4200	1800	2400	3550	1800
50 1 15/16, 2	22211	2200	3800	1800	2200	3200	1600
55 —	22212	2000	3500	1650	2000	3000	1550
60 2 3/16, 2 1/4	22213	1800	3200	1500	1800	2800	1500
65 2 7/16, 2 1/2	22215	1600	2900	1300	1600	2400	1300
70 2 11/16, 2 3/4	22216	1500	2650	1200	1500	2200	1150
75 2 15/16, 3	22217	1400	2400	1100	1400	2000	1100
80 3 3/16, 3 1/4	22218	1400	2400	1000	1400	2000	1000
85 —	22219	1300	2200	1000	1300	1800	950
90 3 7/16, 3 1/2	22220	1200	2000	900	1200	1600	900
100 3 15/16, 4	22222	900	1700	600	900	1200	600
110 4 3/16, 4 1/4	22224	800	1600	500	800	1100	500
115 4 7/16, 4 1/2	22226	700	1500	400	700	1000	400
125 4 15/16, 5	22228	650	1200	350	650	900	350

⁽¹⁾Bearings with contact seals will have higher operating temperatures than bearings with labyrinth seals.

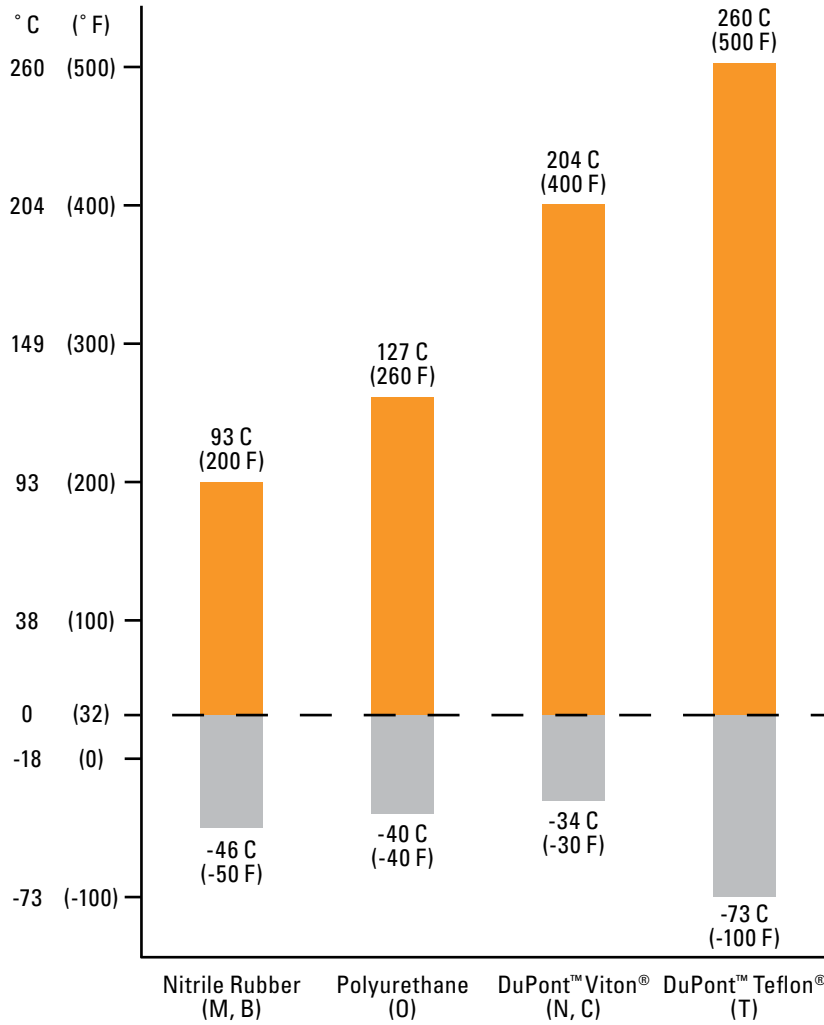

Fig. 16. Seal temperature ratings based on analytics.

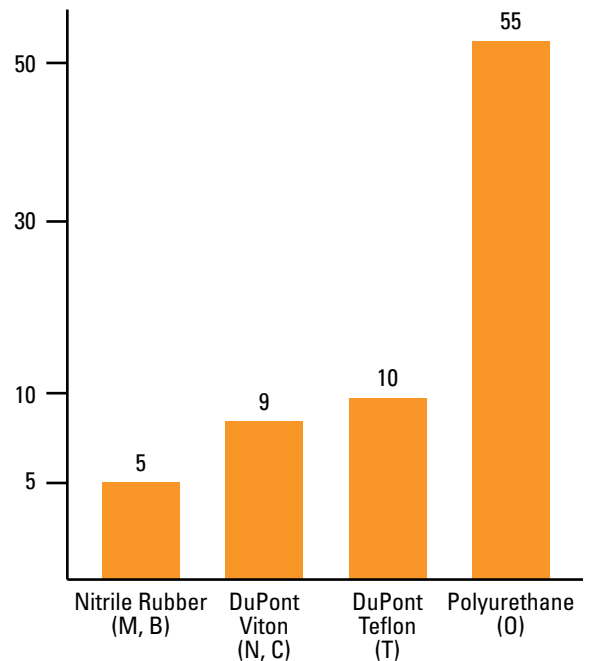

Fig. 17. Relative abrasion resistance ratings.

DuPont™ is a trademark of E.I. du Pont de Nemours and Company.
 Teflon® is a registered trademark of E.I. du Pont de Nemours and Company.
 Viton® is a registered trademark of E.I. du Pont de Nemours and Company.

SEAL MATERIAL CHEMICAL COMPATIBILITY

A - Little to no effect B - Minor to moderate effect C - Severe effect to destruction N - No data – test prior to use.	Urethane	Nitrile rubber	DuPont™ Viton®	DuPont™ Teflon®
Acetaldehyde	C	C	C	A
Acetamide	N	A	B	A
Acetic Acid	C	B	B	A
Acetic Anhydride	C	C	C	A
Acetone	C	C	C	A
Acetyl Bromide	C	N	N	N
Acetyl Chloride	C	C	A	A
Acetylene	C	A	A	A
Adipic Acid	A	A	N	A
Aero Shell Grease	B	A-B	A	A
Aero Lubriplate	A	A	A	A
Aero Safe 2300	N	C	C	A
Aerzine 50	N	C	C	A
Aluminum Acetate	N	A	C	A
Aluminum Bromide	N	A	A	A
Aluminum Chloride	B	A	A	A
Aluminum Sulfate	B	A	A	A
Ammonia	B	B	C	A
Ammonium Carbonate	B	C	N	A
Ammonium Chloride	N	A	A	A
Ammonium Hydroxide	B	C	A	A
Ammonium Nitrate	B	A	N	A
Ammonium Persulfate	B	C	N	A
Ammonium Sulfate	B	A	C	A
Ammonium Sulfide	B	A	C	A
Ammonium Thiocyanate	B	N	N	A
Ammonium Acetate	C	N	N	A
Amyl Acetate	C	C	C	A
Amyl Alcohol	C	B	C	A
Aniline	C	C	C	A
Aniline Hydrochloride	C	B	B	B
Animal Fats and Oils	B	A	A	A
Antimony Salts	B	N	N	A
Aqua Regia	C	C	B	A
Arsenic Salts	B	N	N	A
ASTM Oil #1	A	A	A	A
ASTM Oil #2	B	A	A	A
ASTM Oil #3	B	A	A	A
ASTM Reference Fuel A	A	A	A	A
ASTM Reference Fuel B	B	B	A	A
Atlantic Oil	A	A	A	A
Barium Carbonate	B	A	A	A
Barium Hydroxide	A	A	A	A
Beer	A	A	A	A
Benzaldehyde	B	C	C	A
Benzene	C	C	B	A
Benzoic Acid	B	C	A	A
Black Sulphate Liquors	N	B	A	A

A - Little to no effect B - Minor to moderate effect C - Severe effect to destruction N - No data – test prior to use.	Urethane	Nitrile rubber	DuPont™ Viton®	DuPont™ Teflon®
Bleach Solutions	N	C	A	B
Boric Acid	A	A	A	A
Brake Fluid	N	C	C	N
Bromine	B	C	A	C
Bunker Oil	A	A	A	A
Butane	A	A	A	A
Butyl Acetate	C	C	C	A
Butyl Alcohol	B	A	A	A
Calcium Carbonate	B	A	A	A
Calcium Chloride	A	A	A	A
Calcium Hydroxide	A	A	A	A
Calcium Nitrate	B	A	A	A
Calcium Sulfate	B	B	B	A
Carbon Dioxide	A	A	A	A
Carbon Disulfide	B	C	A	A
Carbon Monoxide	A	A	A	A
Carbon Tetrachloride	C	C	A	A
Chlorine	N	C	A	B
Chloroacetic Acid	C	C	C	N
Chloroform	C	N	N	B
Chromic Acid	C	C	A	B
Chromium Potassium Sulfate	A	N	N	N
Citric Acid	B	A	A	A
Corn Oil	A	A	A	A
Cottonseed Oil	A	A	A	A
Cresol	C	C	A	A
Crude Oil	B	B	A	A
Cupric Chloride	A	B	B	A
Cupric Nitrate	B	N	N	A
Cupric Sulfate	B	B	B	A
Cutting Oil	B	A	A	A
Cyclohexane	B	A	A	A
Cyclohexanone	C	C	A	A
Dibutyl Phthalate	C	C	C	B
Dichlorobenzene	C	N	N	B
Diesel Fuel	B	A	A	A
Diester Oil	B	B	A	A
Dimethyl Acetamide	C	N	N	A
Dimethyl Formamide	C	B	C	A
Dodecyl Mercaptan	B	N	N	N
DTE Oil	B	A	N	N
Dubutyl Ether	B	C	C	N
EP Lubes	A	A	A	A
Esso #90 Lube Oil	A	A	A	A
Ether	B	N	N	A
Ethyl Acetate	C	C	C	A
Ethyl Alcohol (Ethanol)	C	A	C	A
Formic Acid	C	B	C	A

DuPont™ is a trademark of E.I. du Pont de Nemours and Company.
Teflon® is a registered trademark of E.I. du Pont de Nemours and Company.
Viton® is a registered trademark of E.I. du Pont de Nemours and Company.

DISCLAIMER: Every reasonable effort has been made to ensure the accuracy of the information in this writing, but no liability is accepted for errors, omissions or for any other reason.

Continued on next page.

Continued from previous page.

A - Little to no effect B - Minor to moderate effect C - Severe effect to destruction N - No data – test prior to use.	Urethane	Nitrile rubber	DuPont™ Viton®	DuPont™ Teflon®
Freon, 12 or 113	A	A	B	A
Fuel Oil	B	A	A	A
Gasoline	B	B	A	A
Glucose	A	A	A	A
Glue	N	A	A	A
Glycerin	A	A	A	A
Heptane	A	N	N	A
Hexane	A	A	A	A
Hydrazine	C	B	C	B
Hydrobromic Acid	B	C	A	A
Hydrocarbon Oil	A	A	A	A
Hydrochloric Acid	B	C	B	A
Hydrofluoric Acid	B	C	C	A
Hydrogen	A	A	A	A
Hydrogen Peroxide	B	C	A	B
Hydrogen Sulfide	C	C	C	A
Hydrologic Acid	B	N	N	N
Iodine	A	B	A	A
Isobutyl Alcohol	N	B	A	A
Isopropyl Chloride	N	C	A	A
Isopropyl Ether	B	B	C	N
Isopropyl Alcohol (Propanol)	B	A	A	N
JP4 Oil	B	A	A	A
JP5 and 6 Oil	C	A	A	A
Kerosene	B	A	A	A
Lactic Acid	B	B	A	A
Lead Acetate	B	B	C	A
Linseed Oil	B	A	A	A
Liquefied Petroleum Gas	A	A	A	N
Lubrication Oil	B	A	A	A
Lye	N	B	B	A
Magnesium Chloride	N	A	A	A
Magnesium Hydroxide	A	B	A	A
Magnesium Salts	B	A	A	A
Maleic Acid	C	C	A	A
Mercury	B	A	A	A
Methyl Alcohol (Methanol)	A	C	A	N
Methyl Ethyl Ketone	C	C	C	A
Methylene Chloride	C	C	B	A
MIL-D-5606 Oil	C	A	A	A
MIL-L7808 Oil	B	B	A	A
Mineral Oil	A	A	A	A
Mineral Spirits	N	B	A	A
Naphthalene	B	C	A	A
Natural Gas	B	A	A	A
Nickel Salts	C	A	A	A
Oxygen	A	B	A	A
Ozone	A	C	A	A

A - Little to no effect B - Minor to moderate effect C - Severe effect to destruction N - No data – test prior to use.	Urethane	Nitrile rubber	DuPont™ Viton®	DuPont™ Teflon®
Palmitic Acid	A	A	A	A
Paint Thinner	B	C	B	A
Peanut Oil	A	A	A	A
Perchloric Acid	C	C	A	A
Perchloroethylene	C	B	A	A
Petroleum	B	A	A	A
Phenol (Carbolic Acid)	C	C	A	A
Phosphoric Acid	C	C	A	A
Potassium Cyanide	A	A	A	A
Potassium Salts	B	A	A	A
Propane	B	A	A	A
Propyl Alcohol	B	A	A	A
Propylene Glycol	B	N	N	A
Pydraul Oil	C	C	A	A
SAE #10 Oil	A	A	A	A
Seawater	A	A	A	A
Silicic Acid	B	N	N	A
Silver Nitrate	B	B	A	A
Skydrol Oil	C	C	C	A
Soap	B	A	A	A
Sodium Acetate	A	B	C	A
Sodium Bicarbonate	B	A	A	A
Sodium Borate	B	A	A	A
Sodium Carbonate	B	A	A	A
Sodium Chloride	B	A	A	A
Sodium Cyanide	B	A	A	A
Sodium Hydrosulfite	B	N	N	A
Sodium Hydroxide	B	B	B	A
Sodium Hypochlorite	C	B	A	A
Sodium Nitrate	B	B	N	A
Sodium Silicate	A	A	A	A
Sodium Sulfate	B	A	A	A
Sodium Sulfide	B	A	A	A
Steam	C	C	C	A
Styrene	B	C	B	A
Sulfur Dioxide	B	C	A	A
Sulfuric Acid	C	C	A	A
Tannic Acid	A	A	A	A
Tartaric Acid	A	A	A	A
Toluene	C	N	N	A
Transformer Oil	B	N	N	A
Turpentine	C	A	A	A
Urea	B	N	N	A
Varnish	B	B	A	A
Water	B	A	A	A

DuPont™ is a trademark of E.I. du Pont de Nemours and Company.

Teflon® is a registered trademark of E.I. du Pont de Nemours and Company.

Viton® is a registered trademark of E.I. du Pont de Nemours and Company.

DISCLAIMER: Every reasonable effort has been made to ensure the accuracy of the information in this writing, but no liability is accepted for errors, omissions or for any other reason.

INTERNAL RADIAL CLEARANCES

TABLE 14. V-LOCK SERIES (TAPERED BORE, C3)

Shaft Dia.	Bearing No.	Clearance		Minimum Permissible RIC After Installation
		Min.	Max.	
mm in.		mm in.	mm in.	mm in.
50 1 15/16, 2	22211	0.075 0.0030	0.095 0.0037	0.038 0.0015
55 2 3/16, 2 1/4	22212	0.075 0.0030	0.095 0.0037	0.038 0.0015
55 2 3/16, 2 1/4	22213	0.075 0.0030	0.095 0.0037	0.038 0.0015
60, 65 2 7/16, 2 1/2	22214	0.094 0.0037	0.119 0.0047	0.043 0.0017
60, 65 2 7/16, 2 1/2	22215	0.094 0.0037	0.119 0.0047	0.043 0.0017
70, 75 2 11/16, 2 3/4, 2 15/16, 3	22216	0.094 0.0037	0.119 0.0047	0.049 0.0017
70, 75 2 11/16, 2 3/4, 2 15/16, 3	22217	0.109 0.0043	0.140 0.0055	0.051 0.0020
80, 85, 90 3 3/16, 3 1/4, 3 7/16, 3 1/2	22219	0.109 0.0043	0.140 0.0055	0.051 0.0020
80, 85, 90 3 3/16, 3 1/4, 3 7/16, 3 1/2	22220	0.109 0.0043	0.140 0.0055	0.051 0.0020
100 3 11/16, 3 3/4, 3 15/16, 4	22222	0.135 0.0053	0.170 0.0067	0.064 0.0025
110 —	22224	0.135 0.0053	0.170 0.0067	0.064 0.0025
110, 115 4 7/16, 4 1/2	22226	0.160 0.0063	0.201 0.0079	0.076 0.0030
125, 130 4 15/16, 5	22228	0.160 0.0063	0.201 0.0079	0.076 0.0030

TABLE 15. CL SERIES (STRAIGHT BORE, C NORMAL)

Shaft Dia.	Bearing No.	Clearance	
		Min.	Max.
mm in.		mm in.	mm in.
35 1 7/16, 1 1/2	22208	0.030 0.0012	0.045 0.0018
40, 45 1 11/16, 1 3/4	22209	0.035 0.0014	0.055 0.0022
50 1 15/16, 2	22210	0.040 0.0016	0.065 0.0026
55 2 3/16, 2 1/4	22211	0.040 0.0016	0.065 0.0026
60, 65 2 7/16, 2 1/2	22213	0.040 0.0016	0.065 0.0026
70, 75 2 11/16, 2 3/4, 2 15/16, 3	22215	0.050 0.002	0.080 0.0031
80, 85, 90 3 3/16, 3 1/4, 3 7/16, 3 1/2	22218	0.060 0.0024	0.100 0.0039
100 3 15/16, 4	22220	0.075 0.003	0.120 0.0047
110, 115 4 7/16, 4 1/2	22222	0.075 0.003	0.120 0.0047
125, 130 4 15/16, 5	22226	0.095 0.0037	0.145 0.0057

TABLE 16. EC SERIES (STRAIGHT BORE, C NORMAL)

Shaft Dia.	Bearing No.	Clearance		Shaft Dia.	Bearing No.	Clearance	
		Min.	Max.			Min.	Max.
mm in.		mm in.	mm in.	mm in.		mm in.	mm in.
35 1 7/16, 1 1/2	22208	0.030 0.0012	0.045 0.0018	80, 85, 90 3 3/16, 3 1/4 3 7/16, 3 1/2	22218	0.060 0.0024	0.100 0.0039
40, 45 1 11/16, 1 3/4	22209	0.0350 0.0014	0.055 0.0022	100 3 11/16, 3 3/4 3 15/16, 4	22220	0.075 0.003	0.120 0.0047
50 1 15/16, 2	22210	0.040 0.0016	0.065 0.0026	110, 115 4 7/16, 4 1/2	22222	0.075 0.003	0.120 0.0047
55 2 3/16, 2 1/4	22211	0.040 0.0016	0.065 0.0026	125, 130 4 15/16, 5	22226	0.095 0.0037	0.145 0.0057
60, 65 2 7/16, 2 1/2	22213	0.040 0.0016	0.065 0.0026	140, 150 5 7/16, 5 1/2 5 15/16, 6	23230	0.110 0.0043	0.170 0.0067
70, 75 2 11/16, 2 3/4 2 15/16, 3	22215	0.050 0.002	0.080 0.0031	170, 180 6 7/16, 6 1/2, 6 15/16, 7	23234	0.120 0.0047	0.180 0.0071

TABLE 17. TA/DV SERIES (TAPERED BORE, C3)

Shaft Dia.	Bearing No.	Clearance Prior To Installation		Recommended Reduction Of Internal Radial Clearance		Recommended Axial Movement Of Adapter Sleeve		Minimum Internal
		Min.	Max.	Min.	Max.	Min.	Max.	
mm in.		mm in.	mm in.	mm in.	mm in.	mm in.	mm in.	mm in.
40 1 7/16, 1 1/2	22209	0.061 0.0024	0.079 0.0031	0.025 0.0010	0.030 0.0012	0.381 0.015	0.457 0.018	0.030 0.0012
45 1 11/16, 1 3/4	22210	0.061 0.0024	0.079 0.0031	0.025 0.0010	0.030 0.0012	0.381 0.015	0.457 0.018	0.030 0.0012
50 1 15/16, 2	22211	0.076 0.0030	0.094 0.0037	0.030 0.0012	0.038 0.0015	0.457 0.018	0.559 0.022	0.038 0.0015
55 —	22212	0.076 0.0030	0.094 0.0037	0.030 0.0012	0.038 0.0015	0.457 0.018	0.559 0.022	0.038 0.0015
60 2 3/16, 2 1/4	22213	0.076 0.0030	0.094 0.0037	0.030 0.0012	0.038 0.0015	0.457 0.018	0.559 0.022	0.038 0.0015
65 2 7/16, 2 1/2	22215	0.094 0.0037	0.119 0.0047	0.038 0.0015	0.051 0.0020	0.559 0.022	0.762 0.030	0.043 0.0017
70 2 11/16, 2 3/4	22216	0.094 0.0037	0.119 0.0047	0.038 0.0015	0.051 0.0020	0.559 0.022	0.762 0.030	0.043 0.0017
75 2 15/16, 3	22217	0.109 0.0043	0.140 0.0055	0.046 0.0018	0.064 0.0025	0.686 0.027	0.965 0.038	0.051 0.0020
80 3 3/16, 3 1/4	22218	0.109 0.0043	0.140 0.0055	0.046 0.0018	0.064 0.0025	0.686 0.027	0.965 0.038	0.051 0.0020
85 —	22219	0.109 0.0043	0.140 0.0055	0.046 0.0018	0.064 0.0025	0.686 0.027	0.965 0.038	0.051 0.0020
90 3 7/16, 3 1/2	22220	0.109 0.0043	0.140 0.0055	0.046 0.0018	0.064 0.0025	0.686 0.027	0.965 0.038	0.051 0.0020
100 3 15/16, 4	22222	0.135 0.0053	0.170 0.0067	0.051 0.0020	0.071 0.0028	0.762 0.030	1.067 0.042	0.064 0.0025
110 4 3/16, 4 1/4	22224	0.135 0.0053	0.170 0.0067	0.051 0.0020	0.071 0.0028	0.762 0.030	1.067 0.042	0.064 0.0025
115 4 7/16, 4 1/2	22226	0.160 0.0063	0.201 0.0079	0.064 0.0025	0.089 0.0035	0.889 0.035	1.270 0.050	0.076 0.0030
125 4 15/16, 5	22228	0.160 0.0063	0.201 0.0079	0.064 0.0025	0.089 0.0035	0.889 0.035	1.270 0.050	0.076 0.0030

SHAFTING

When installing and using housed unit bearings, all shafting should be straight, clean, free from burrs and within the recommended shaft tolerances in tables 18 and 19 below. For applications that involve high speed or extreme vibration conditions, we recommend that all shafting be machined to one-half the recommended tolerances below.

SHAFT EXPANSION

Steel expands or contracts 0.0000113 millimeter per millimeter for each degree Celsius (0.0000063 inch per inch for each degree Fahrenheit) relative temperature increase or decrease respectively. Expansion bearings are used to accommodate thermal expansion of steel. Where the shafting and the framework on which the bearings and shafting are mounted are made from steel, the relative difference in expansion between the shaft and the

framework will be minimal. In these conditions, fixed bearings can be used on both ends of the shaft. However, if there is a difference in material between the shaft and the framework, or if the application involves different temperatures from the shaft to the frame, then only one fixed bearing should be used on each shaft. All other bearings on the same shaft should be converted to floating to accommodate thermal expansion of the shaft.

TABLE 18. V-LOCK, CL AND EC SERIES – RECOMMENDED SHAFT TOLERANCES

Shaft Dia.	Shaft Tolerance
mm in.	mm in.
35 1 7/16, 1 1/2	+0.00/-0.025 +0.00/-0.0010
40, 45 1 11/16, 1 3/4	+0.00/-0.038 + 0.00/-0.0015
50 1 15/16, 2	+0.00/-0.038 + 0.00/-0.0015
55 2 3/16, 2 1/4	+0.00/-0.038 + 0.00/-0.0015
60, 65 2 7/16, 2 1/2	+0.00/-0.038 + 0.00/-0.0015
70, 75 2 11/16, 2 3/4, 2 15/16, 3	+0.00/-0.051 + 0.00/-0.0020
80, 85, 90 3 3/16, 3 1/4, 3 7/16, 3 1/2	+0.00/-0.076 + 0.00/-0.0030
100 3 11/16, 3 3/4, 3 15/16, 4	+0.00/-0.076 + 0.00/-0.0030
110, 115 4 7/16, 4 1/2	+0.00/-0.127 + 0.00/-0.0050
125, 130 4 15/16, 5	+0.00/-0.127 + 0.00/-0.0050
140, 150 5 7/16, 5 1/2, 5 15/16, 6	+0.00/-0.127 + 0.00/-0.0050
170, 180 6 7/16, 6 1/2, 6 15/16, 7	+0.00/-0.127 + 0.00/-0.0050

TABLE 19. TA/DV SERIES – RECOMMENDED SHAFT TOLERANCES

Shaft Dia.	Shaft Tolerance
mm in.	mm in.
40 1 7/16, 1 1/2	+0.00/-0.025 +0.00/-0.0010
45 1 11/16, 1 3/4	+0.00/-0.051 +0.00/-0.0020
50 1 15/16, 2	+0.00/-0.076 + 0.00/-0.0030
55 –	+0.00/-0.076 –
60 2 3/16, 2 1/4	+0.00/-0.076 + 0.00/-0.0030
65 2 7/16, 2 1/2	+0.00/-0.089 + 0.00/-0.0035
70 2 11/16, 2 3/4	+0.00/-0.102 + 0.00/-0.0040
75 2 15/16, 3	+0.00/-0.102 + 0.00/-0.0040
80 3 3/16, 3 1/4	+0.00/-0.102 + 0.00/-0.0040
85 –	+0.00/-0.102 –
90 3 7/16, 3 1/2	+0.00/-0.102 + 0.00/-0.0040
100 3 15/16, 4	+0.00/-0.102 + 0.00/-0.0040
110 4 3/16, 4 1/4	+0.00/-0.102 + 0.00/-0.0040
115 4 7/16, 4 1/2	+0.00/-0.102 + 0.00/-0.0040
125 4 15/16, 5	+0.00/-0.127 + 0.00/-0.0050

TABLE 20. AMOUNT OF FLOAT PER ONE ROTATION OF EXTERNAL HOUSING NUT

Bearing Number	Float	Bearing Number	Float	Bearing Number	Float
	mm in.		mm in.		mm in.
22208	1.270 0.050	22215	2.108 0.083	22224	2.108 0.083
22209	1.270 0.050	22216	2.108 0.083	22226	2.108 0.083
22210	1.270 0.050	22217	2.108 0.083	22228	2.108 0.083
22211	1.270 0.050	22218	2.108 0.083	23230	2.108 0.083
22212	1.270 0.050	22219	2.108 0.083	23234	2.108 0.083
22213	2.108 0.083	22220	2.108 0.083	–	–
22214	2.108 0.083	22222	2.108 0.083	–	–

CONVERSION FROM FIXED TO FLOATING

Housed unit bearings are easily converted from fixed to floating in the field (see the appropriate installation guide in this catalog for instructions). The following table will help you determine the amount of float for each bearing based on the number of revolutions the external housing nut is backed out.

MISALIGNMENT

All spherical roller bearing housed units utilize self-aligning double-row spherical roller bearings. Because of this, the housed unit can accommodate angular misalignment of 1.5 degrees. The performance life of our housed unit is not reduced while under misalignment conditions within these guidelines. It will accept both radial and thrust loads under static, oscillatory or dynamic load conditions.

TABLE 21. MISALIGNMENT SCALE AT 1.5 DEGREES

A	B
m ft.	mm in.
0.305 1	7.981 0.314
1.524 5	39.905 1.570

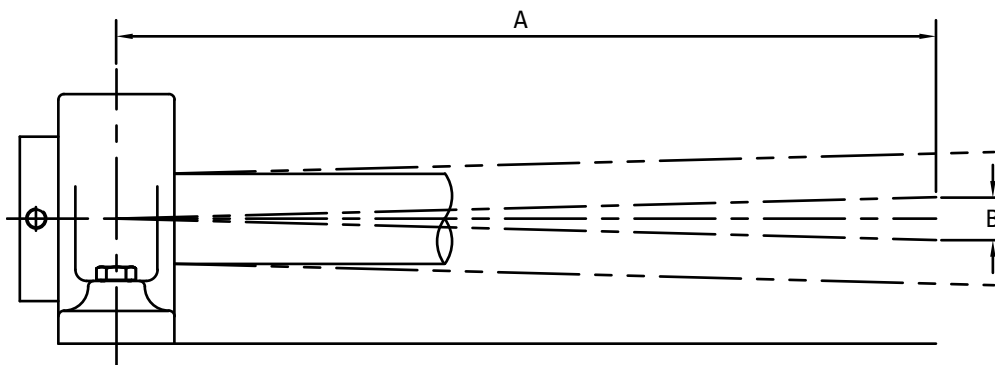

Fig. 18. Misalignment.

LUBRICATION

Timken is dedicated to using the highest quality components in everything we do. This is why we use premium industrial grease in spherical roller bearing solid-block housed units. The lithium-complex extreme-pressure grease combines the benefits of wide operating temperatures and broad compatibility. This grease offers excellent thermal stability through temperatures ranging from -34° C to 177° C (-30° F to 350° F). When dealing with temperatures above 149° C (300° F), consult your Timken engineer for optional grease recommendations. Application-specific lubrication options are also available ranging from Timken Food Safe Grease (aluminum-complex) to Timken Mill grease (calcium-sulfonate) along with many others.

European REACH Compliance

Timken lubricants, greases and similar products sold in stand-alone containers or delivery systems are subject to the European REACH (Registration, Evaluation, Authorization and Restriction of CHemicals) directive. For import into the European Union, Timken can sell and provide only those lubricants and greases that are registered with ECHA (European CHemical Agency). For further information, please contact your Timken engineer.

INSTALLATION GUIDES

V-LOCK® SERIES

Timken® solid-block housed unit V-Lock® bearings are easy to install and remove because of their unique adapters.

Please complete the following steps to install and/or remove Timken steel housed unit V-Lock bearings. (Refer to fig. 19.)

- Ensure that the shaft is clean, free from nicks and burrs, straight and of proper diameter. See table 23 for recommended shaft tolerances. The housed unit should not be mounted on a worn section of the shaft. Using shafts with hardness greater than HRC 45 will reduce the effectiveness of locking devices.
- If using an open-end cover, slide the open-end cover/seal combination into position on the shaft.
- Remove the wedge assembly from the sleeve by unscrewing the wedge nut. See fig. 19.
- Clean oil off of the sleeve and wedge.
- Apply a thin oil film to the shaft only.
 - For **QV** single-nut housed units:
 - Slide the sleeve, non-threaded end first, into position on the shaft.
 - For **QVV** double-nut housed units:
 - Make sure the sleeve nut is flush with the end of the sleeve.
 - Slide the sleeve/nut assembly, nut end first, into position on the shaft.
- Slide the housed unit into place over the sleeve.
- Loosely install the housed unit mounting bolts. Check the

housed unit alignment. Verify that the mounting surfaces are in the same flat plane to help achieve good alignment. If shimming is required to minimize misalignment, use full shims across the entire housing base where possible (fig. 20). Washers should be properly sized to bolt diameter and should not be an SAE grade, which is smaller.

- Seat the sleeve as best as possible into the mounted unit.
- Tighten the wedge assembly by turning the wedge nut clockwise until tight. Please note that it is designed to prevent overtightening.
- If installing a double-nut housed unit, tighten the sleeve assembly by turning the sleeve nut clockwise until snug.
- Tighten both the wedge nut and sleeve nut set screws alternately according to fig. 19.
- Install the housed unit mounting bolts. Check the housed unit alignment. Verify that the mounting surfaces are in the same flat plane to achieve good alignment. If shimming is required to minimize misalignment, use full shims across the entire housing base where possible (fig. 20). The bolts then need to be alternately torqued securely to their mounting supports.
- Tighten the housing mounting bolts.

If using covers:

- Make sure the mating surface of the cover and retaining nuts are clean and dry.
 - Urethane cover: slightly roughen the mating surface

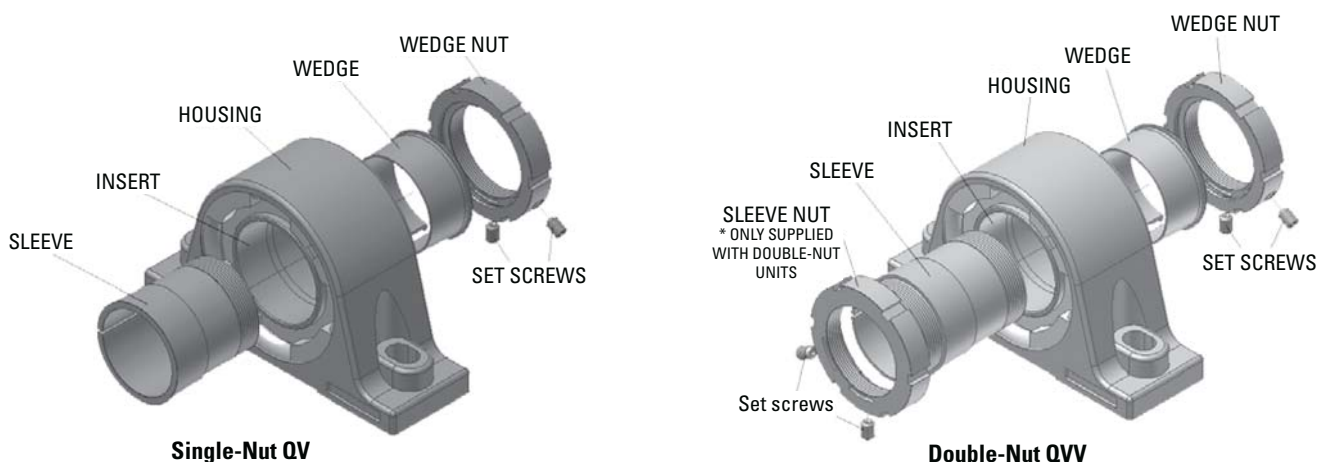

Fig. 19. V-Lock® insert components.

TABLE 22. SET SCREW TORQUE VALUES

Bearing Size	Bore	Set Screw Size	Torque
			Nm Nm/in. - lbs.
SLV11 to SLV20	Metric Imperial	M10 X 1.5 3/8-24 TPI	35 32.8/290
SLV22	Metric Imperial	M12 X 1.75 7/16-20 TPI	57 47.5/420
SLV24 to SLV28	Metric Imperial	M12 X 1.75 1/2-20 TPI	57 70.1/620

of the cover, place a 3 mm – 6 mm (1/8 in. – 1/4 in.) bead of polyurethane adhesive sealant on the roughened surface.

- Steel cover: place a 3 mm – 6 mm (1/8 in. – 1/4 in.) bead of silicone adhesive sealant on the mating surface of the cover.
- Align the cover mounting holes with the mounting holes on the retaining housing nut (make sure that the grease fitting on the cover is accessible when doing so).
- Apply and tighten the cover mounting hardware.

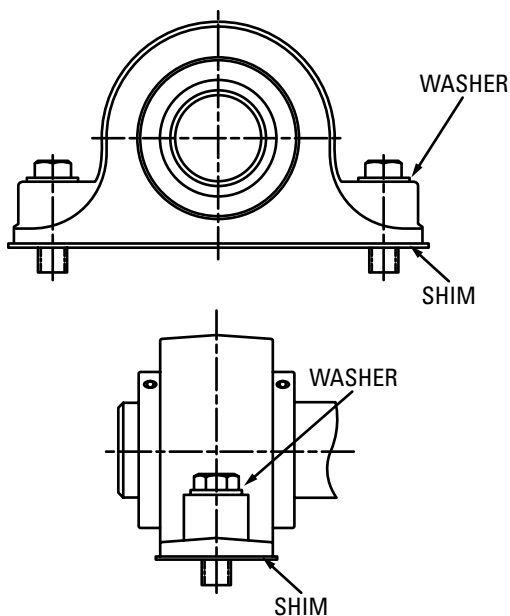

Fig. 20. Use washers and full shims.

REMOVAL

- Remove covers, if applicable, by removing cover hardware and disengaging the cover from the housed unit retaining nut.
- Loosen the set screws on the wedge nut.
- Turn the wedge nut counterclockwise to remove the wedge from the locked position.
- Completely remove the wedge/wedge nut assembly.
 - For **QV** housed units:
 - Remove the bearing and sleeve from the shaft.
 - For **QVV** housed units:
 - Loosen the set screws on the sleeve nut.
 - Turn the sleeve nut clockwise to un-seat the sleeve.
 - Remove the bearing and sleeve/sleeve nut from the shaft.

TABLE 23. RECOMMENDED SHAFT TOLERANCES

Shaft Dia.	Bearing No.	Tolerance
mm in.		mm in.
50 1 15/16, 2	22211	+0.00/-0.038 +0.00/-0.0015
55 2 3/16, 2 1/4	22212 22213	
60, 65 2 7/16, 2 1/2	22214 22215	
70, 75 2 11/16, 2 3/4, 2 15/16, 3	22216 22217	+0.00/-0.051 +0.00/-0.0020
80, 85, 90 3 3/16, 3 1/4, 3 7/16, 3 1/2	22219 22220	+0.00/-0.076 +0.00/-0.0030
100 3 11/16, 3 15/16, 4	22222	+0.00/-0.076 +0.00/-0.0030
110, 115 4 7/16, 4 1/2	22224 22226	+0.00/-0.127 +0.00/-0.0050
125, 130 4 15/16, 5	22228	

HOW TO CONVERT A SOLID-BLOCK HOUSED UNIT FROM FIXED TO EXPANSION (FLOATING)

Flange Cartridge and Flange Block

- Make a reference mark on the housing and retaining nut.
- Loosen the Teflon-tipped set screw that locks the retaining nut in place.
- Loosen the retaining nut by tapping it with a hammer and punch, rotating the retaining nut counterclockwise one complete revolution.
- Tighten the Teflon-tipped set screw.

Pillow Block

- Decide the amount and direction of expansion that's needed. If unidirectional expansion is required, follow the directions outlined in the previous page for flange housed units on the nut that is on the side you want the expansion.
- If multi-directional expansion is required, follow the directions outlined in the previous section for both nuts on flange housed units.

HOW TO CONVERT A SOLID-BLOCK HOUSED UNIT FROM EXPANSION (FLOATING) TO FIXED

Flange Cartridge and Flange Block

- Loosen the Teflon-tipped set screw that locks the retaining nut in place.



WARNING

Failure to observe the following warnings could create a risk of death or serious injury.

Proper maintenance and handling practices are critical. Always follow installation instructions and maintain proper lubrication.

Overheated bearings can ignite explosive atmospheres. Special care must be taken to properly select, install, maintain, and lubricate housed unit bearings that are used in or near atmospheres that may contain explosive levels of combustible gases or accumulations of dust such as from grain, coal, or other combustible materials. Consult your equipment designer or supplier for installation and maintenance instructions.

If hammer and bar are used for installation or removal of a part, use a mild steel bar (e.g., 1010 or 1020 grade). Mild steel bars are less likely to cause release of high speed fragments from the hammer or bar or the part being installed or removed.

- Tighten the retaining nut by tapping it with a hammer and punch, rotating the retaining nut clockwise until it's tight. It is not possible to overtighten the retaining nut.
- Tighten the Teflon-tipped set screw.

NOTE

When converting a solid-block housed unit bearing from fixed to expansion, it is imperative that the unit that is going to be converted is correctly oriented. Since the insert in a steel housed unit flange bearing is held against either a shoulder or snap ring opposite the housing retaining nut, a flange bearing that has been converted to expansion can only float in the direction of the retaining nut. Based on this, the retaining nut must be on the side of the housing opposite the fixed bearing.

Pillow Block

- Follow the directions above for flange housed units on both nuts on either side of the housing.

NOTE

When converting a solid-block housed unit from expansion to fixed on a mounted bearing, the locking-collar set screws must be released to allow the insert to move both in the housing and on the shaft.

LUBRICATION

This information is to aid in the proper lubrication of Timken spherical roller bearing solid-block housed units for the majority of applications.

Housed units have been factory-prelubricated with an NLGI No. 2 lithium-complex, extreme-pressure synthetic grease that combines the benefits of wide operating temperatures and broad compatibility with varied materials. This grease offers excellent thermal stability through temperatures ranging from -40° C to 177° C (-40° F to 350° F). Housed units should be relubricated with this grease or one that is compatible and made for roller bearings. It is vital that the greases used are compatible. Please consult with your Timken engineer for the grease specifications if the use of a grease other than the grease mentioned above is needed.

Normal service is considered as operation in a clean, dry environment at temperatures between -34° C to +82° C (-30° F to +180° F). If service is beyond normal conditions due to speed, temperature, or exposure to moisture, dirt or corrosive chemicals,

more frequent relubrication may be necessary. For extreme conditions or conditions in which special chemicals are used, consult with your Timken engineer.

After extended storage or periods when the housed unit is not in operation, fresh grease should be added.

It's important to have the right amount of lubrication, because it affects the housed unit bearing operating temperature as well. An inadequate amount of grease could lead to higher operating temperatures due to inadequate lubrication film thickness. Excessive grease also will lead to higher operating temperatures due to grease churning, which can cause bearing overheating. It is best to observe the bearing and its temperature and adjust the lubrication as needed. If necessary, use the purge valve or seals that purge to reduce the amount of grease.

NOTE

Please check with the manufacturer of your grease delivery system for specific information.

RELUBRICATION

Adequate lubrication is an essential element to the housed unit bearing life. Use table 24 as a suggested initial point of reference. Relubrication frequency and quantity intervals are best determined through experience for each application, based on types of service, which may differ from the suggestions in the table.

When the housed unit is not in operation for an extended period of time, grease should be added to prevent corrosion.

Table 24 shows general lubrication suggested starting points only. Please read the entire installation instructions prior to using these tables. Applications should be regularly reviewed and lubrication amounts and intervals modified as needed to ensure best results.

TABLE 24. RELUBRICATION INTERVALS

Shaft Diameter	Bearing No.	Initial Weight	Relubrication Weight	Relubrication Interval (Hours of Service based on RPM and Temperature deg. F)											
				100 RPM		250 RPM		500 RPM		1000 RPM		2000 RPM		3000 RPM	
				<160°	>160°	<160°	>160°	<160°	>160°	<160°	>160°	<160°	>160°	<160°	>160°
mm in.		g oz.	g oz.												
50 1 15/16, 2	22211	28.4 1	8.5 0.3	1200	600	800	400	440	220	160	80	100	50	60	30
55 2 3/16, 2 1/4	22212	34.0 1.2	8.5 0.3	1150	580	750	380	400	200	140	70	90	50	50	20
	22213	36.9 1.3	11.3 0.4	1130	570	740	370	380	190	130	65	85	45	45	20
60, 65 2 7/16, 2 1/2	22214	39.7 1.4	11.3 0.4	1120	560	720	360	360	180	120	60	80	40	40	20
	22215	56.7 2	14.2 0.5	1080	540	700	350	350	175	110	55	70	35		
70, 75 2 11/16, 2 3/4 2 15/16, 3	22216	76.5 2.7	19.9 0.7	1040	520	680	340	340	170	100	50	60	30		
	22217	96.4 3.4	25.5 0.9	1000	500	640	320	320	160	100	50	60	30		
80, 85, 90 3 3/16, 3 1/4 3 7/16, 3 1/2	22219	104.9 3.7	25.5 0.9	960	480	600	300	300	150	80	40	40	20		
	22220	184.3 6.5	45.4 1.6	840	420	520	260	240	120	70	35	30	18		
100 3 11/16, 3 3/4 3 15/16, 4	22222	209.8 7.4	53.9 1.9	680	340	440	220	200	100	60	30	20	16		
110, 115 4 7/16, 4 1/2	22224	260.8 9.2	68.0 2.4	640	320	400	200	180	90	50	25				
	22226	300.5 10.6	76.5 2.7	560	280	360	180	160	80						
125, 130 4 15/16, 5	22228	396.9 14	99.2 3.5	520	260	340	170	140	75						

DISCLAIMER: Every reasonable effort has been made to ensure the accuracy of the information in this writing, but no liability is accepted for errors, omissions or for any other reason.

CL SERIES

Please complete the following steps to install Timken solid-block housed unit CL Series bearings.

- Ensure that the shaft is clean, free from nicks and burrs, straight and of proper diameter. See table 25 for recommended shaft tolerances. The housed unit should not be mounted on a worn section of the shaft. Using shafts with hardness greater than HRC 45 will reduce the effectiveness of locking devices.
- If using an open-end cover, slide the open-end cover/seal combination into position on the shaft.
- Apply a thin oil film to the shaft and bearing bore.
- Slide the housed unit into position on the shaft.
- Install the housed unit mounting bolts. Check the housed unit alignment. Verify mounting surfaces are in the same flat plane to help achieve good alignment. If shimming is required to minimize misalignment, use full shims across the entire housing base where possible (fig. 22). The bolts then need to be alternately torqued securely to their mounting supports.
- Tighten set screws alternately as per table 26. Set screws in multiple units should be aligned to each other (fig. 21).

If using covers:

- Make sure the mating surface of the cover and retaining nuts are clean and dry.
 - Urethane cover: slightly roughen the mating surface of the cover, place a 3 mm – 6 mm (1/8 in. – 1/4 in.) bead of polyurethane adhesive sealant on the roughened surface.
 - Steel cover: place a 3 mm – 6 mm (1/8 in. – 1/4 in.) bead of silicone adhesive sealant on the mating surface of the cover.
- Align the cover mounting holes with the mounting holes on the retaining housing nut (make sure that the grease fitting on the cover is accessible when doing so).
- Apply and tighten the cover mounting hardware.

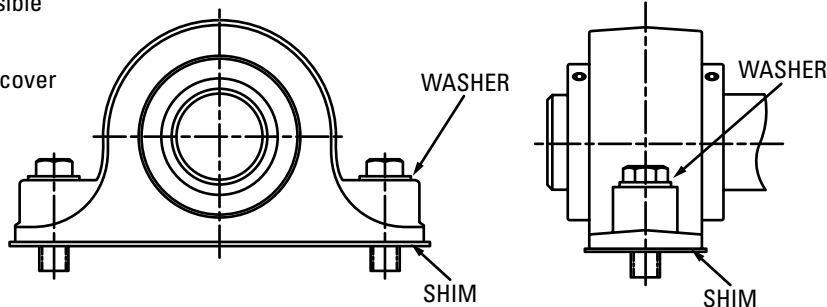

Fig. 22. Use washers and full shims.

TABLE 25. RECOMMENDED SHAFT TOLERANCES

Shaft Dia.	Bearing No.	Tolerance
mm in.		mm in.
35 1 7/16, 1 1/2	22208	+0.00/-0.025 +0.00/0.0010
40, 45 1 1/16, 1 3/4	22209	+0.00/-0.038 +0.00/0.0015
50 1 15/16, 2	22210	+0.00/-0.038 +0.00/-0.0015
55 2 3/16, 2 1/4	22211	+0.00/-0.038 +0.00/-0.0015
60, 65 2 7/16, 2 1/2	22213	+0.00/-0.038 +0.00/-0.0015
70, 75 2 11/16, 2 3/4 2 15/16, 3	22215	+0.00/-0.51 +0.00/-0.0020
80, 85, 90 3 3/16, 3 1/4 3 7/16, 3 1/2	22218	+0.00/-0.076 +0.00/-0.0030
100 3 15/16, 4	22220	+0.00/-0.076 +0.00/-0.0030
110, 115 4 7/16, 4 1/2	22222	+0.00/-0.127 +0.00/-0.0050
125, 130 4 15/16, 5	22226	+0.00/-0.127 +0.00/-0.0050

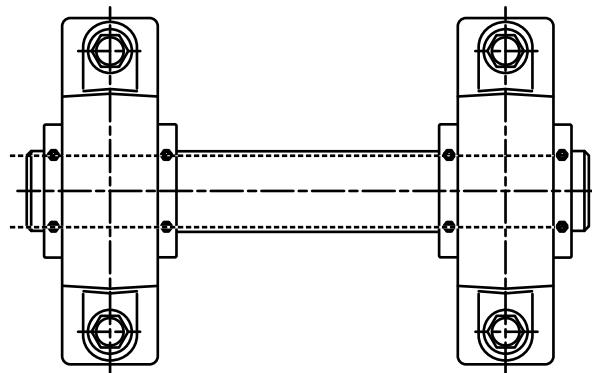

Fig. 21. Line up set screws in multiple units.

TABLE 26. SET SCREW TORQUE VALUES

Shaft Dia.	Bearing No.	Set Screw Size	Torque
mm in.		mm in.	Nm Nm/in. - lbs.
35 1 7/16, 1 1/2	22208	M10 X 1.5 3/8 - 24 TPI	35 32.8/290
40, 45 1 11/16, 1 3/4	22209	M10 X 1.5 3/8 - 24 TPI	35 32.8/290
50 1 15/16, 2	22210	M10 X 1.5 3/8 - 24 TPI	35 32.8/290
55 2 3/16, 2 1/4	22211	M10 X 1.5 3/8 - 24 TPI	35 32.8/290
60, 65 2 7/16, 2 1/2	22213	M12 X 1.75 1/2 - 20 TPI	57 70.1/620
70, 75 2 11/16, 2 3/4 2 15/16, 3	22215	M12 X 1.75 1/2 - 20 TPI	57 70.1/620
80, 85, 90 3 3/16, 3 1/4 3 7/16, 3 1/2	22218	M12 X 1.75 1/2 - 20TPI	57 70.1/620
100 3 15/16, 4	22220	M16 X 2 5/8 - 18 TPI	126 149.7/1325
110, 115 4 7/16, 4 1/2	22222	M16 X 2 5/8 - 18 TPI	126 149.7/1325
125, 130 4 15/16, 5	22226	M16 X 2 5/8 - 18 TPI	126 149.7/1325

LUBRICATION

This information is to aid in the proper lubrication of Timken spherical roller bearing solid-block housed units for the majority of applications.

Housed units have been factory-prelubricated with an NLGI No. 2 lithium-complex, extreme pressure synthetic grease that combines the benefits of wide operating temperatures and broad compatibility with varied materials. This grease offers excellent thermal stability through temperatures ranging from -40° C to 177° C (-40° F to 350° F). Housed units should be relubricated with this grease or one that is compatible and made for roller bearings. It is vital that the greases used are compatible. Please consult with your Timken engineer for the grease specifications if the use of a grease other than the grease mentioned above is needed.

Normal service is considered as operation in a clean, dry environment at temperatures between -34° C to +82° C (-30° F to +180° F). If service is beyond normal conditions due to speed, temperature, or exposure to moisture, dirt or corrosive chemicals, periodic relubrication may be necessary. For extreme conditions or conditions in which special chemicals are used, consult with your Timken engineer.

After extended storage or periods when the housed unit is not in operation, fresh grease should be added.

It's important to have the right amount of lubrication, because it affects the housed unit bearing operating temperature as well. An inadequate amount of grease could lead to higher operating temperatures due to inadequate lubrication film thickness. Excessive grease also will lead to higher operating temperatures due to grease churning, which can cause bearing overheating. It is best to observe the bearing and its temperature and adjust the lubrication as needed. If necessary, use the purge valve or seals that purge to reduce the amount of grease.

NOTE

Please check with the manufacturer of your grease delivery system for specific information.



WARNING

Failure to observe the following warnings could create a risk of death or serious injury.

Proper maintenance and handling practices are critical. Always follow installation instructions and maintain proper lubrication.

Overheated bearings can ignite explosive atmospheres. Special care must be taken to properly select, install, maintain, and lubricate housed unit bearings that are used in or near atmospheres that may contain explosive levels of combustible gases or accumulations of dust such as from grain, coal, or other combustible materials. Consult your equipment designer or supplier for installation and maintenance instructions.

If hammer and bar are used for installation or removal of a part, use a mild steel bar (e.g., 1010 or 1020 grade). Mild steel bars are less likely to cause release of high speed fragments from the hammer or bar or the part being installed or removed.

RELUBRICATION

Adequate lubrication is an essential element to the housed unit bearing life. Use table 27 as a suggested initial point of reference. Relubrication frequency and quantity intervals are best determined through experience for each application based on types of service, which may differ from the suggestions in the table.

When the housed unit is not in operation for an extended period of time, grease should be added to prevent corrosion.

Table 27 shows general lubrication suggested starting points only. Please read the entire installation instructions prior to using these tables. Applications should be regularly reviewed and lubrication amounts and intervals modified as needed to ensure the best results.

TABLE 27. RELUBRICATION INTERVALS

Shaft Dia.	Bearing No.	Initial Weight	Relubrication Weight	Relubrication Interval (Hours of Service based on RPM and Temperature deg. F)											
				100 RPM		250 RPM		500 RPM		1000 RPM		2000 RPM		3000 RPM	
				<160°	>160°	<160°	>160°	<160°	>160°	<160°	>160°	<160°	>160°	<160°	>160°
mm in.		g oz.	g oz.												
35 1 7/16, 1 1/2	22208	14.2 0.5	2.4 0.1	2200	1000	1400	700	1000	500	240	120	120	60	40	20
40, 45 1 11/16, 1 3/4	22209	19.9 0.7	5.7 0.2	2000	1000	1200	600	800	400	320	160	160	80	80	40
50 1 15/16, 2	22210	22.7 0.8	5.7 0.2	1600	800	1000	500	640	320	240	120	120	60	60	30
55 2 3/16, 2 1/4	22211	28.4 1	8.5 0.3	1200	600	800	400	440	220	160	80	100	50	60	30
60, 65 2 7/16, 2 1/2	22213	39.7 1.4	11.3 0.4	1120	560	720	360	360	180	120	60	80	40	40	20
70, 75 2 11/16, 2 3/4 2 15/16, 3	22215	76.5 2.7	19.4 0.7	1040	520	680	340	340	170	100	50	60	30		
80, 85, 90 3 3/16, 3 1/4 3 7/16, 3 1/2	22218	104.9 3.7	25.5 0.9	960	480	600	300	300	150	80	40	40	20		
100 3 15/16, 4	22220	184.3 6.5	45.4 1.6	840	420	520	260	240	120	60	30	20	16		
110, 115 4 7/16, 4 1/2	22222	209.8 7.4	53.9 1.9	680	340	440	220	200	100	60	30	20	16		
125, 130 4 15/16, 5	22226	300.5 10.6	76.5 2.7	560	280	360	180	160	80						

DISCLAIMER: Every reasonable effort has been made to ensure the accuracy of the information in this writing, but no liability is accepted for errors, omissions or for any other reason.

HOW TO CONVERT A SOLID-BLOCK HOUSED UNIT FROM FIXED TO EXPANSION (FLOATING)

Flange Cartridge and Flange Block

- Make a reference mark on the housing and retaining nut.
- Loosen the Teflon-tipped set screw that locks the retaining nut in place.
- Loosen the retaining nut by tapping it with a hammer and punch, rotating the retaining nut counterclockwise one complete revolution.
- Tighten the Teflon-tipped set screw.

NOTE

When converting a solid-block housed unit bearing from fixed to expansion, it is imperative that the unit that is going to be converted is correctly oriented. Since the insert in a steel housed unit flange bearing is held against either a shoulder or snap ring opposite the housing retaining nut, a flange bearing that has been converted to expansion can only float in the direction of the retaining nut. Based on this, the retaining nut must be on the side of the housing opposite the fixed bearing.

Pillow Block

- Decide the amount and direction of expansion that's needed. If unidirectional expansion is required, follow the directions outlined above for flange bearings on the nut that is on the side you want the expansion.
- If multi-directional expansion is required, follow the directions as outlined above for both nuts on flange housed units.

HOW TO CONVERT A SOLID-BLOCK HOUSED UNIT FROM EXPANSION (FLOATING) TO FIXED

Flange Cartridge and Flange Block

- Loosen the Teflon-tipped set screw that locks the retaining nut in place.
- Tighten the retaining nut by tapping it with a hammer and punch, rotating the retaining nut clockwise until it's tight. It is not possible to overtighten the retaining nut.
- Tighten the Teflon-tipped set screw.

Pillow Block

- Follow the directions above for flange bearings on both nuts on either side of the housing.

NOTE

When converting a solid-block housed unit from expansion to fixed on a mounted bearing, the locking-collar set screws must be released to allow the insert to move both in the housing and on the shaft.

EC SERIES

Please complete the following steps to install Timken EC series spherical roller bearing solid-block housed units.

- Ensure that the shaft is clean, free from nicks and burrs, straight and of proper diameter. See table 28 for recommended shaft tolerances. The housed unit should not be mounted on a worn section of the shaft. Using shafts with hardness greater than HRC 45 will reduce the effectiveness of locking devices.
- If using an open-end cover, slide the open-end cover/seal combination into position on the shaft.
- Apply a thin oil film to the shaft and bearing bore.
- Slide the housed unit into position on the shaft.
- Install the housed unit mounting bolts. Check the housed unit alignment. Verify that the mounting surfaces are in the same flat plane to help achieve good alignment. If shimming is required to minimize misalignment, use full shims across the entire housing base where possible (fig. 23). The bolts then need to be alternately torqued securely to their mounting supports.

- Slide the eccentric locking collar along shaft and onto the extended portion of the bearing's inner ring.
- Rotate the eccentric locking collar until it is hand-tight (the direction of rotation does not matter).
- Lock the eccentric locking collar firmly in place by using a spanner wrench or a hammer and drift.

When using a hammer and drift, one or two firm, but not too hard, blows will be sufficient due to the shallow eccentric ramp on EC series housed units. Make sure you drive the collar in the same direction in which you hand-tightened it so as to turn it to a tighter position on the bearing's inner ring.

- Tighten the eccentric locking collar set screws alternately as per table 29.

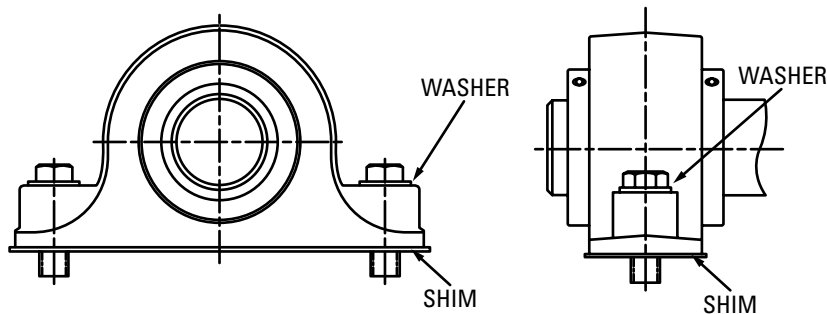

Fig. 23. Use washers and full shims.

If using covers:

- Make sure the mating surface of the cover and retaining nuts are clean and dry.
 - Urethane cover: slightly roughen the mating surface of the cover, place a 3 mm – 6 mm (1/8 in. – 1/4 in.) bead of polyurethane adhesive sealant on the roughened surface.
 - Steel cover: place a 3 mm – 6 mm (1/8 in. – 1/4 in.) bead of silicone adhesive sealant on the mating surface of the cover.
- Align the cover mounting holes with the mounting holes on the retaining housing nut (make sure that the grease fitting on the cover is accessible when doing so).
- Apply and tighten the cover mounting hardware.

TABLE 28. RECOMMENDED SHAFT TOLERANCES

Shaft Dia.	Bearing No.	Tolerance
mm in.		mm in.
35 1 7/16, 1 1/2	22208	+0.00/-0.025 +0.00/-0.0010
40, 45 1 11/16, 1 3/4	22209	+0.00/-0.038 +0.00/-0.0015
50 1 15/16, 2	22210	+0.00/-0.038 +0.00/-0.0015
55 2 3/16, 2 1/4	22211	+0.00/-0.038 +0.00/-0.0015
60, 65 2 7/16, 2 1/2	22213	+0.00/-0.038 +0.00/-0.0015
70, 75 2 11/16, 2 3/4 2 15/16, 3	22215	+0.00/-0.051 +0.00/-0.0020
80, 85, 90 3 3/16, 3 1/4 3 7/16, 3 1/2	22218	+0.00/-0.076 +0.00/-0.0030
100 3 11/16, 3 3/4 3 15/16, 4	22220	+0.00/-0.076 +0.00/-0.0030
110, 115 4 7/16, 4 1/2	22222	+0.00/-0.127 +0.00/-0.0050
125, 130 4 15/16, 5	22226	+0.00/-0.127 +0.00/-0.0050
140, 150 5 7/16, 5 1/2 5 15/16, 6	23230	+0.00/-0.127 +0.00/-0.0050
170, 180 6 7/16, 6 1/2 6 15/16, 7	23234	+0.00/-0.127 +0.00/-0.0050

TABLE 29. SET SCREW TORQUE VALUES

Shaft Dia.	Bearing No.	Set Screw Size	Torque
mm in.		mm in.	Nm Nm/in. - lbs.
35 1 7/16, 1 1/2	22208	M8 X 1.25 5/16 - 24 TPI	17.8 18.6/165
40, 45 1 11/16, 1 3/4	22209	M10 X 1.5 3/8 - 24 TPI	35 32.8/290
50 1 15/16, 2	22210	M10 X 1.5 3/8 - 24 TPI	35 32.8/290
55 2 3/16, 2 1/4	22211	M10 X 1.5 3/8 - 24 TPI	35 32.8/290
60, 65 2 7/16, 2 1/2	22213	M12 X 1.75 7/16 - 20 TPI	57 70.1/620
70, 75 2 11/16, 2 3/4 2 15/16, 3	22215	M12 X 1.75 7/16 - 20 TPI	57 70.1/620
80, 85, 90 3 3/16, 3 1/4 3 7/16, 3 1/2	22218	M12 X 1.75 7/16 - 20 TPI	57 70.1/620
100 3 11/16, 3 3/4 3 15/16, 4	22220	M16 X 2 5/8 - 18 TPI	126 149.7/1325
110, 115 4 7/16, 4 1/2	22222	M16 X 2 5/8 - 18 TPI	126 149.7/1325
125, 130 4 15/16, 5	22226	M16 X 2 5/8 - 18 TPI	126 149.7/1325
140, 150 5 7/16, 5 1/2 5 15/16, 6	23230	M16 X 2 5/8 - 18 TPI	126 149.7/1325
170, 180 6 7/16, 6 1/2 6 15/16, 7	23234	M16 X 2 5/8 - 18 TPI	126 149.7/1325

LUBRICATION

This information is to aid in the proper lubrication of Timken spherical roller bearing solid-block housed units for the majority of applications.

Housed units have been factory-prelubricated with an NLGI No. 2 lithium-complex, extreme-pressure synthetic grease that combines the benefits of wide operating temperatures and broad compatibility with varied materials. This grease offers excellent thermal stability through temperatures ranging from -40° C to 177° C (-40° F to 350° F). Housed units should be relubricated with this grease or one that is compatible and made for roller bearings. It is vital that the greases used are compatible. Please consult with your Timken engineer for the grease specifications if the use of a grease other than the grease mentioned above is needed.

Normal service is considered as operation in a clean, dry environment at temperatures between -34° C to +82° C (-30° F to +180° F). If service is beyond normal conditions due to speed, temperature, or exposure to moisture, dirt or corrosive chemicals, periodic relubrication may be necessary. For extreme conditions or conditions in which special chemicals are used, consult with your Timken engineer.

After extended storage or periods when the housed unit is not in operation, fresh grease should be added.

It's important to have the right amount of lubrication, because it affects the housed unit bearing operating temperature as well. An inadequate amount of grease could lead to higher operating temperatures due to inadequate lubrication film thickness. Excessive grease also will lead to higher operating temperatures due to grease churning, which can cause bearing overheating. It is best to observe the bearing and its temperature and adjust the lubrication as needed. If necessary, use the purge valve or seals that purge to reduce the amount of grease.

NOTE

Please check with the manufacturer of your grease delivery system for specific information.

RELUBRICATION

Adequate lubrication is an essential element to the housed unit bearing life. Use table 30 as a suggested initial point of reference. Relubrication frequency and quantity intervals are best developed through experience for each application based on types of service, which may differ from the suggestions in the table.

When the housed unit is not in operation for an extended period of time, grease should be added to prevent corrosion.

Table 30 shows general lubrication suggested starting points only. Please read the entire installation instructions prior to using these tables. Applications should be regularly reviewed and lubrication amounts and intervals modified as needed to ensure the best results.



WARNING

Failure to observe the following warnings could create a risk of death or serious injury.

Proper maintenance and handling practices are critical. Always follow installation instructions and maintain proper lubrication.

Overheated bearings can ignite explosive atmospheres. Special care must be taken to properly select, install, maintain, and lubricate housed unit bearings that are used in or near atmospheres that may contain explosive levels of combustible gases or accumulations of dust such as from grain, coal, or other combustible materials. Consult your equipment designer or supplier for installation and maintenance instructions.

If hammer and bar are used for installation or removal of a part, use a mild steel bar (e.g., 1010 or 1020 grade). Mild steel bars are less likely to cause release of high speed fragments from the hammer or bar or the part being installed or removed.

DISCLAIMER

Every reasonable effort has been made to ensure the accuracy of the information in this writing, but no liability is accepted for errors, omissions or for any other reason.

TABLE 30. RELUBRICATION INTERVALS

Shaft Dia.	Bearing No.	Initial Weight	Relubrication Weight	Relubrication Interval (Hours of Service based on RPM and Temperature deg. F)											
				100 RPM		250 RPM		500 RPM		1000 RPM		2000 RPM		3000 RPM	
				<160°	>160°	<160°	>160°	<160°	>160°	<160°	>160°	<160°	>160°	<160°	>160°
mm in.		g oz.	g oz.												
35 1 7/16, 1 1/2	22208	14.2 0.5	2.8 0.1	2200	1000	1400	700	1000	500	240	120	120	60	40	20
40, 45 1 11/16, 1 3/4	22209	19.9 0.7	5.7 0.2	2000	1000	1200	600	800	400	320	160	160	80	80	40
50 1 15/16, 2	22210	22.7 0.8	5.7 0.2	1600	800	1000	500	640	320	240	120	120	60	60	30
55 2 3/16, 2 1/4	22211	28.4 1	8.5 0.3	1200	600	800	400	440	220	160	80	100	50	60	30
60, 65 2 7/16, 2 1/2	22213	39.7 1.4	11.3 0.4	1120	560	720	360	360	180	120	60	80	40	40	20
70, 75 2 11/16, 2 3/4 2 15/16, 3	22215	76.5 2.7	19.8 0.7	1040	520	680	340	340	170	100	50	60	30		
80, 85, 90 3 3/16, 3 1/4 3 7/16, 3 1/2	22218	104.9 3.7	25.5 0.9	960	480	600	300	300	150	80	40	40	20		
100 3 11/16, 3 3/4 3 15/16, 4	22220	184.3 6.5	45.4 1.6	840	420	520	260	240	120	60	30	20	16		
110, 115 4 7/16, 4 1/2	22222	209.8 7.4	53.9 1.9	680	340	440	220	200	100	60	30	20	16		
125, 130 4 15/16, 5	22226	300.5 10.6	76.5 2.7	560	280	360	180	160	80						
140, 150 5 7/16, 5 1/2 5 15/16, 6	23230	589.7 20.8	147.4 5.2	480	240	320	160	120	68						
170, 180 6 7/16, 6 1/2 6 15/16, 7	23234	850.0 30.0	241.0 8.5	400	160	240	160	110	60						

HOW TO CONVERT A SOLID-BLOCK HOUSED UNIT FROM FIXED TO EXPANSION (FLOATING)

Flange Cartridge and Flange Block

- Make a reference mark on the housing and retaining nut.
- Loosen the Teflon-tipped set screw that locks the retaining nut in place.
- Loosen the retaining nut by tapping it with a hammer and punch, rotating the retaining nut counterclockwise one complete revolution.
- Tighten the Teflon-tipped set screw.

NOTE

When converting a solid-block housed unit bearing from fixed to expansion, it is imperative that the unit that is going to be converted is correctly oriented. Since the insert in a steel housed unit flange bearing is held against either a shoulder or snap ring opposite the housing retaining nut, a flange bearing that has been converted to expansion can only float in the direction of the retaining nut. Based on this, the retaining nut must be on the side of the housing opposite the fixed bearing.

Pillow Block

- Decide the amount and direction of expansion that's needed. If unidirectional expansion is required, follow the directions outlined above for flange bearings on the nut that is on the side you want the expansion.
- If multi-directional expansion is required, follow the directions outlined above for both nuts on flange housed units.

HOW TO CONVERT A SOLID-BLOCK HOUSED UNIT FROM EXPANSION (FLOATING) TO FIXED

Flange Cartridge and Flange Block

- Loosen the Teflon-tipped set screw that locks the retaining nut in place.
- Tighten the retaining nut by tapping it with a hammer and punch, rotating the retaining nut clockwise until it's tight. It is not possible to overtighten the retaining nut.
- Tighten the Teflon-tipped set screw.

Pillow Block

- Follow the directions above for flange bearings on both nuts on either side of the housing.

NOTE

When converting a solid-block housed unit from expansion to fixed on a mounted bearing, the locking collar set screws must be released to allow the insert to move both in the housing and on the shaft.

TA/DV SERIES

Choose one of the following two methods for installing your housed unit depending on your situation. Timken recommends the axial drive-up method for most applications. If your application is not as critical, the simpler tang counting method is fine.

AXIAL DRIVE-UP METHOD

- Clean all components of any debris and apply a thin oil film to all mating surfaces to ensure proper seating.
- If using an open-end cover, slide the open-end cover/seal combination into position on the shaft.
- Slide the adapter sleeve into position on the shaft, then put the housed unit into place on the adapter sleeve.
- Loosely install the housed unit mounting bolts. Check the housed unit alignment. Verify mounting surfaces are in the same flat plane to help achieve good alignment. If shimming is required to minimize misalignment, use full shims across the entire housing base where possible (fig. 24). Washers should be properly sized to the bolt diameter and should not be an SAE grade, which is smaller.
- Put the lockwasher on and thread the locknut onto the adapter sleeve leaving approximately 6.350 mm (¼ in.) between the lockwasher and the inner ring of the bearing.
- Use a large screwdriver or pry bar to lever the sleeve into position until there is no relative movement between the shaft, the adapter sleeve, and the bearing's inner ring.
- Rotate the locknut until hand-tight.
- Tighten the locknut while using a dial indicator to measure the axial movement of the tapered adapter sleeve relative to the bearing's inner ring (see table 31).
- Bend a tang on the lockwasher into a slot on the locknut to prevent the locknut from loosening.
- Tighten the housed unit mounting bolts.

If using covers:

- Make sure the mating surface of the cover and retaining nuts are clean and dry.
 - Urethane cover: slightly roughen the mating surface of the cover, place a 3 mm – 6 mm (⅛ in. – ¼ in.) bead of polyurethane adhesive sealant on the roughened surface.
 - Steel cover: place a 3 mm – 6 mm (⅛ in. – ¼ in.) bead of silicone adhesive sealant on the mating surface of the cover.
- Align the cover mounting holes with the mounting holes on the retaining housing nut (make sure that the grease fitting on the cover is accessible when doing so).
- Apply and tighten the cover mounting hardware.

TABLE 31. AXIAL MOVEMENT OF TAPERED ADAPTER SLEEVE RELATIVE TO INNER RING

Shaft Dia.	Bearing No.	Minimum Axial Movement	Maximum Axial Movement
mm in.		mm in.	mm in.
40 1 7/16, 1 1/2	22209	0.38 0.015	0.46 0.018
45 1 11/16, 1 3/4	22210	0.38 0.015	0.46 0.018
50 1 15/16, 2	22211	0.46 0.018	0.56 0.022
55 —	22212	0.46 0.018	0.56 0.022
60 2 3/16, 2 1/4	22213	0.46 0.018	0.56 0.022
65 2 7/16, 2 1/2	22215	0.64 0.025	0.76 0.030
70 2 11/16, 2 3/4	22216	0.64 0.025	0.76 0.030
75 2 15/16, 3	22217	0.69 0.027	0.97 0.038
80 3 3/16, 3 1/4	22218	0.69 0.027	0.97 0.038
85 —	22219	0.69 0.027	0.97 0.038
90 3 7/16, 3 1/2	22220	0.69 0.027	0.97 0.038
100 3 15/16, 4	22222	0.76 0.030	1.07 0.042
110 4 3/16, 4 1/4	22224	0.76 0.030	1.07 0.042
115 4 7/16, 4 1/2	22226	0.89 0.035	1.27 0.050
125 4 15/16, 5	22228	0.89 0.035	1.27 0.050

TANG COUNTING METHOD

- Clean all components of any debris and apply a thin oil film to all mating surfaces to ensure proper seating.
- If using an open-end cover, slide the open-end cover/seal combination into position on the shaft.
- Slide the adapter sleeve into the correct position on the shaft, then put the housed unit into place on the adapter sleeve.
- Loosely install the housed unit mounting bolts. Check the housed unit alignment. Verify mounting surfaces are in the same flat plane to help achieve good alignment. If shimming is required to minimize misalignment, use full shims across the entire housing base where possible (fig. 24). Washers should be properly sized to the bolt diameter and should not be an SAE grade, which is smaller.
- Put the lockwasher on and thread the locknut onto the adapter sleeve, leaving approximately $\frac{1}{4}$ in. between the lockwasher and the inner ring of the bearing.
- Use a large screwdriver or pry bar to lever the sleeve into position until there is no relative movement between the shaft, the adapter sleeve and the bearing's inner ring.
- Rotate the locknut until hand-tight.
- Note which tang is in line with one slot on the locknut.
- Tighten the locknut until the slot on the locknut passes the number of tangs shown in table 32.
- Bend a tang on the lockwasher into a slot on the locknut to prevent the locknut from loosening.
- Tighten the housed unit mounting bolts.

If using covers:

- Make sure the mating surface of the cover and retaining nuts are clean and dry.
 - Urethane cover: slightly roughen the mating surface of the cover, place a 3 mm – 6 mm ($\frac{1}{8}$ in. – $\frac{1}{4}$ in.) bead of polyurethane adhesive sealant on the roughened surface.
 - Steel cover: place a 3 mm – 6 mm ($\frac{1}{8}$ in. – $\frac{1}{4}$ in.) bead of silicone adhesive sealant on the mating surface of the cover.
- Align the cover mounting holes with the mounting holes on the retaining housing nut (make sure that the grease fitting on the cover is accessible when doing so).
- Apply and tighten the cover mounting hardware.

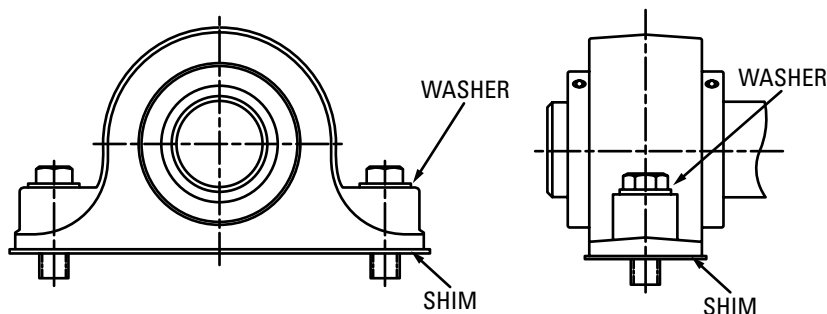

Fig. 24. Use washers and full shims.

TABLE 32. NUMBER OF TANGS TO LOCKING

Shaft Dia.	Bearing No.	Number of Tangs
mm in.		
40 1 7/16, 1 1/2	22209	3-4
45 1 11/16, 1 3/4	22210	3-4
50 1 15/16, 2	22211	4-5
55 —	22212	4-5
60 2 3/16, 2 1/4	22213	4-5
65 2 7/16, 2 1/2	22215	5-6
70 2 11/16, 2 3/4	22216	5-6
75 2 15/16, 3	22217	8-9
80 3 3/16, 3 1/4	22218	8-9
85 —	22219	8-9
90 3 7/16, 3 1/2	22220	8-9
100 3 15/16, 4	22222	10-11
110 4 3/16, 4 1/4	22224	10-11
115 4 7/16, 4 1/2	22226	10-11
125 4 15/16, 5	22228	10-11

LUBRICATION

This information is to aid in the proper lubrication of Timken spherical roller bearing solid-block housed units for the majority of applications.

Housed units have been factory-prelubricated with an NLGI No. 2 lithium-complex, extreme-pressure synthetic grease that combines the benefits of wide operating temperatures and broad compatibility with varied materials. This grease offers excellent thermal stability through temperatures ranging from -40° C to 177° C (-40° F to 350° F). Housed units should be relubricated with this grease or one that is compatible and made for roller bearings. It is vital that the greases used are compatible. Please consult with your Timken engineer for the grease specifications if the use of a grease other than the grease mentioned above is needed.

Normal service is considered as operation in a clean, dry environment at temperatures between -34° C to +82° C (-30° F to +180° F). If service is beyond normal conditions due to speed, temperature or exposure to moisture, dirt or corrosive chemicals, periodic relubrication may be necessary. For extreme conditions or conditions in which special chemicals are used, consult with your Timken engineer.

After extended storage or periods when the housed unit is not in operation, fresh grease should be added.

It's important to have the right amount of lubrication, because it affects the housed unit bearing operating temperature as well. An inadequate amount of grease could lead to higher operating temperatures due to inadequate lubrication film thickness. Excessive grease will lead to higher operating temperatures due to grease churning, which can cause bearing overheating. It is best to observe the bearing and its temperature and adjust the lubrication as needed. If necessary, use the purge valve or seals that purge to reduce the amount of grease.

NOTE

Please check with the manufacturer of your grease delivery system for specific information.

RELUBRICATION

Adequate lubrication is an essential element to the housed unit bearing life. Use table 33 as a suggested initial point of reference. Relubrication frequency and quantity intervals are best determined through experience for each application based on types of service, which may differ from the suggestions in the table.

When the housed unit is not in operation for an extended period of time, grease should be added to prevent corrosion.

Table 33 shows general lubrication suggested starting points only. Please read the entire installation instructions prior to using these tables. Applications should be regularly reviewed and lubrication amounts and intervals modified as needed to ensure the best results.



WARNING

Failure to observe the following warnings could create a risk of death or serious injury.

Proper maintenance and handling practices are critical. Always follow installation instructions and maintain proper lubrication.

Overheated bearings can ignite explosive atmospheres. Special care must be taken to properly select, install, maintain, and lubricate housed unit bearings that are used in or near atmospheres that may contain explosive levels of combustible gases or accumulations of dust such as from grain, coal, or other combustible materials. Consult your equipment designer or supplier for installation and maintenance instructions.

If hammer and bar are used for installation or removal of a part, use a mild steel bar (e.g., 1010 or 1020 grade). Mild steel bars are less likely to cause release of high speed fragments from the hammer or bar or the part being installed or removed.

TABLE 33. RELUBRICATION INTERVALS

Shaft Dia.	Bearing No.	Initial Weight	Relubrication Weight	Relubrication Interval (Hours of Service based on RPM and Temperature deg. F)											
				100 RPM		250 RPM		500 RPM		1000 RPM		2000 RPM		3000 RPM	
				<160°	>160°	<160°	>160°	<160°	>160°	<160°	>160°	<160°	>160°	<160°	>160°
mm in.		g oz.	g oz.												
40 1 7/16, 1 1/2	22209	19.8 0.7	5.7 0.2	2000	1000	1200	600	800	400	320	160	160	80	80	40
45 1 11/16, 1 3/4	22210	22.7 0.8	5.7 0.7	1600	800	1000	500	640	320	240	120	120	60	60	30
50 1 15/16, 2	22211	28.4 1.0	8.5 0.3	1200	600	800	400	440	220	160	80	100	50	60	30
55 —	22212	34.0 1.2	8.5 0.3	1150	580	750	380	400	200	140	70	90	50	50	20
60 2 3/16, 2 1/4	22213	39.7 1.4	11.3 0.4	1120	560	720	360	360	180	120	60	80	40	40	20
65 2 7/16, 2 1/2	22215	76.5 2.7	19.8 0.7	1040	520	680	340	340	170	100	50	60	30		
70 2 11/16, 2 3/4	22216	76.5 2.7	19.8 0.7	1040	520	680	340	340	170	10	50	60	30		
75 2 15/16, 3	22217	96.4 3.4	25.5 0.9	1000	500	640	320	320	160	100	50	60	30		
80 3 3/16, 3 1/4	22218	104.9 3.7	25.5 0.9	960	480	600	300	300	150	80	40	40	20		
85 —	22219	104.9 3.7	25.5 0.9	960	480	600	300	300	150	80	40	40	20		
90 3 7/16, 3 1/2	22220	184.3 6.5	45.4 1.6	840	420	520	260	240	120	60	30				
100 3 15/16, 4	22222	209.8 7.4	53.9 1.9	680	340	440	220	200	100	60	30				
110 4 3/16, 4 1/4	22224	260.8 9.2	68.0 2.4	640	320	400	200	180	90	50	25				
115 4 7/16, 4 1/2	22226	340.2 12.0	85.0 3.0	600	300	360	180	160	80	40	20				
125 4 15/16, 5	22228	396.9 14.0	99.2 3.5	520	260	340	170	140	75						

DISCLAIMER: Every reasonable effort has been made to ensure the accuracy of the information in this writing, but no liability is accepted for errors, omissions or for any other reason.

HOW TO CONVERT A SOLID-BLOCK HOUSED UNIT FROM FIXED TO EXPANSION (FLOATING)

Flange Cartridge and Flange Block

- Make a reference mark on the housing and retaining nut.
- Loosen the Teflon-tipped set screw that locks the retaining nut in place.
- Loosen the retaining nut by tapping it with a hammer and punch, rotating the retaining nut counterclockwise one complete revolution.
- Tighten the Teflon-tipped set screw.

NOTE

When converting a solid-block housed unit bearing from fixed to expansion, it is imperative that the unit that is going to be converted is correctly oriented. Since the insert in a steel housed unit flange bearing is held against either a shoulder or snap ring opposite the housing retaining nut, a flange bearing that has been converted to expansion can only float in the direction of the retaining nut. Based on this, the retaining nut must be on the side of the housing opposite the fixed bearing.

Pillow Block

- Decide the amount and direction of expansion that's needed. If unidirectional expansion is required, follow the directions outlined above for flange bearings on the nut that is on the side you want the expansion.
- If multi-directional expansion is required, follow the directions above for both nuts on flange housed units.

HOW TO CONVERT A SOLID-BLOCK HOUSED UNIT FROM EXPANSION (FLOATING) TO FIXED

Flange Cartridge and Flange Block

- Loosen the Teflon-tipped set screw that locks the retaining nut in place.
- Tighten the retaining nut by tapping it with a hammer and punch, rotating the retaining nut clockwise until tight. It is not possible to overtighten the retaining nut.
- Tighten the Teflon-tipped set screw.

Pillow Block

- Follow the directions above for flange bearings on both nuts on either side of the housing.

NOTE

When converting a solid-block housed unit from expansion to fixed on a mounted bearing, the locking-collar set screws must be released to allow the insert to move both in the housing and on the shaft.

PRODUCT DATA TABLES

When your equipment faces harsh environments, you need spherical roller bearing solid-block housed units rugged enough to withstand tough conditions and deliver exceptional performance. You gain both with Timken® spherical roller bearing solid-block housed units.

Nomenclatures.....	60
Seal and Cover Options.....	65
V-Lock® Series (double taper lock).....	80
CL Series (concentric [set screw] lock).....	107
EC Series (eccentric lock).....	137
TA/DV Series (tapered adapter lock).....	161
Take-Up Frames.....	177

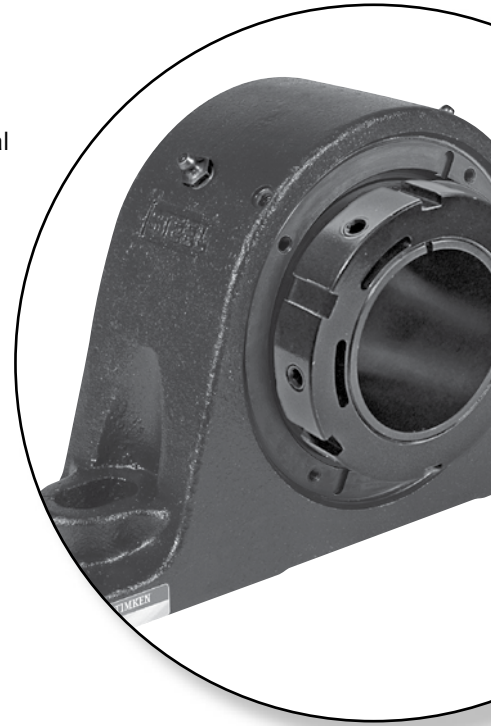

SPHERICAL ROLLER BEARING SOLID-BLOCK HOUSED UNIT NOMENCLATURE

QM P 13 J 207 S E M NG

<p>LOCKING STYLE QM – eccentric lock QA – concentric (set screw) lock, single-collar QAA – concentric (set screw) lock, double-collar QV – V-Lock®, single-nut QVV – V-Lock, double-nut DV – tapered adapter lock (heavy-duty block) TA – tapered adapter lock (extreme-duty block)</p>									
<p>HOUSING STYLE P – Type E dimension two-bolt pillow block PL – two-bolt pillow block, S2000 style PA – SAF-style two-bolt pillow block PN – SN-style two-bolt pillow block SN – SN-style two-bolt pillow block PKT – 9000 series two-bolt pillow block PXT – 5000 series two-bolt pillow block PR – Type E dimension four-bolt pillow block PF – four-bolt pillow block, S2000 style PH – SAF-style four-bolt pillow block PG – SN-style four-bolt pillow block PK – 9000 series four-bolt pillow block PX – 5000 series four-bolt pillow block F – square flange block FB – square flange block FL – square flange block FX – 5000 series flange block FY – round flange block FK – 9000 series flange block C – piloted flange cartridge CW – piloted flange cartridge FC – piloted flange cartridge MC – cartridge block TU – take-up block</p>									
<p>BEARING INSERT BORE SERIES 222XX (i.e., 13 = 22213) 232XX (for size 30 and 34 bearing only)</p>									
<p>BEARING INSERT LOCKING TYPE J – EC series A and AA – CL series V – V-Lock series K – TA/DV series</p>									
<p>SHAFT DIAMETER In inch (i.e., 207 = 2 7/16 in.) and metric (i.e., 050 = 50 mm) sizes</p>									
<p>CAST-STEEL HOUSING</p>									
<p>EXPANSION OR NON-EXPANSION BLANK (No letter) – Non-expansion (fixed) E – Expansion (floating)</p>									
<p>SEAL TYPE M – M seal (triple-lip nitrile rubber) N – N seal (triple-lip DuPont™ Viton®) O – O seal (triple-lip urethane) B – B seal (double-lip nitrile rubber) C – C seal (double-lip Viton) T – T seal (DuPont™ Teflon® labyrinth) YDR – flange cartridge backing plate with DR triple-lip seal DuPont™ is a trademark of E.I. du Pont de Nemours and Co. Teflon® is a registered trademark of E.I. du Pont de Nemours and Co. Viton® is a registered trademark of E.I. du Pont de Nemours and Co.</p>									
<p>ADDITIONAL OFFERINGS NG – No Grease FG – Food Grade Grease XY – Xylan® Coated NP – Nickel Plated DK – Dykor® Coated</p>									

STEEL COVER NOMENCLATURE

CJ **18** **T** **085** **S**

Open-End Steel Cover

LOCKING STYLE

CA – concentric lock
 CJ – eccentric lock
 CV – V-Lock
 CK – tapered adapter lock

BEARING INSERT SERIES

222XX (i.e., 13 = 22213)
 232XX (for size 30 and 34 bearing only)

SEAL TYPE

T seal only

SHAFT SIZE

In inch (i.e., 207 = 2 7/16 in.) and metric (i.e., 050 = 50 mm) sizes

STEEL COVER

CS **18** **STEEL**

Closed-End Steel Cover

BEARING INSERT SERIES

222XX (i.e., 13 = 22213)
 232XX (for size 30 and 34 bearing only)

STEEL COVER

URETHANE COVER NOMENCLATURE

Open-End Cover with DR Seal

CJ **DR** **207**

LOCKING STYLE CA – concentric lock CJ – eccentric lock CK – tapered adapter lock
TRIPLE-LIP SECONDARY SEAL
SHAFT SIZE In inch (i.e., 207 = 2 7/16 in.) and metric (i.e., 050 = 50 mm) sizes

Open-End Cover with VR Seal

CJ **VR** **13**

LOCKING STYLE CV – V-Lock CA – concentric lock CJ – eccentric lock CK – tapered adapter lock
SEAL TYPE VR ring
BEARING INSERT SERIES 222XX (i.e., 13 = 22213) 232XX (for size 30 and 34 bearing only)

V-Lock® Open-End Cover with DR Seal

CV **DR** **13** – **085**

LOCKING STYLE CV – V-Lock
TRIPLE-LIP SECONDARY SEAL
BEARING INSERT SERIES 222XX (i.e., 13 = 22213) 232XX (for size 30 and 34 bearing only)
SHAFT SIZE In inch (i.e., 207 = 2 7/16 in.) and metric (i.e., 050 = 50 mm) sizes

CS **13**

Closed-End Cover
BEARING INSERT SERIES 222XX (i.e., 13 = 22213) 232XX (for size 30 and 34 bearing only)

BACKING PLATE NOMENCLATURE

Backing Plate (Only Available for CA and CJ Series Bearings)

UFP **207**

SQUARE FLANGE BLOCK WITH VR SEAL

SHAFT SIZE
In inch (i.e., 207 = 2 7/16 in.) and metric (i.e., 050 = 50 mm) sizes

Backing Plate (Only Available for CA and CJ Series Bearings)

HSY **085**

ROUND PILOTED FLANGE CARTRIDGE WITH DR SEAL

SHAFT SIZE
In inch (i.e., 207 = 2 7/16 in.) and metric (i.e., 050 = 50 mm) sizes

High Performance Steel Backing Plate (Only Available for CA and CJ Series Bearings)

BP **10** **T** **115** **S**

LOCKING STYLE
CV – V-Lock

BEARING INSERT SERIES
222XX (i.e., 10 = 22210)

SEAL TYPE
T - T seal (DuPont™ Teflon® labyrinth)

SHAFT SIZE
In inch (i.e., 207 = 2 7/16 in.) and metric (i.e., 050 = 50 mm) sizes

STEEL

ORDERING SOLID-BLOCK HOUSED UNITS

Every solid-block housed unit is made of cast steel for greater strength (compared to cast iron). All bearings feature a double-row, spherical roller bearing design for a high load-carrying capacity, misalignment tolerance and reduced friction.

Starting with these standard design advantages, you can choose from a wide range of sizes, locking styles, seal options and housing styles suited precisely for your application.

There are many ways to determine the correct solid-block housed unit part number for ordering purposes:

- Once you determine the best locking style, housing and seal options for your application, you can easily find the correct part number in the tables included in the following sections.
- If you are ordering a replacement for an existing housed unit, locate the part number for that housed unit on the housing tag.
- If none of the above apply, or if you have additional questions or concerns about ordering the correct housed unit, contact your Timken engineer.

SEAL AND COVER OPTIONS

PRIMARY SEALS

Primary seals are installed between the inner ring of the bearing and the housing. They are held securely in place by the external housing nut. Primary seals can be contacting or non-contacting, purging or non-purging and are available in several material compounds for a variety of applications.

TRIPLE-LIP SEALS – CONTACTING, SELF-PURGING, LOW TO MODERATE SPEEDS⁽¹⁾

Timken offers three kinds of medium-contact triple-lip seals. Choose from seals made of nitrile synthetic rubber (acrylonitrile butadiene), DuPont™ Viton® fluoroelastomer or urethane.

- **M Seal** – This seal, made of nitrile rubber, offers superior sealing in moist and dirty applications. It is chemical- and corrosion-resistant and provides excellent lubrication retention. It also allows excess grease to purge from the bearing cavity.
- **N Seal** – Made of DuPont Viton, this seal provides excellent chemical resistance and can operate at higher temperatures than nitrile rubber.
- **O Seal** – Made of high-strength urethane for superior abrasion resistance.

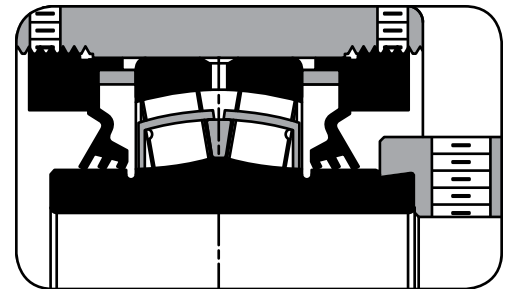

Fig. 25. Triple-lip seals.

LABYRINTH SEALS – NON-CONTACTING, NON-PURGING, ALL SPEEDS⁽²⁾

Instead of trying to form a seal with a single strong barrier, a labyrinth seal uses a winding passageway to accomplish the same reduction in flow. Not only is seal friction reduced, but so is seal wear.

- **T Seal** – This seal consists of a DuPont™ Teflon® ring pressed onto the inner ring of the bearing that floats between two pieces of formed steel to accommodate misalignment. When using this seal, the housing comes with a vent fitting. Developed for higher-speed applications involving dirty conditions or moisture-affected areas, it is able to operate at higher temperatures and is impervious to most chemicals.

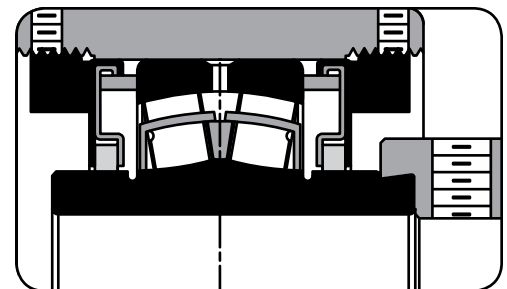

Fig. 26. T seal.

DOUBLE-LIP SEALS – CONTACTING, NON-PURGING, LOW SPEEDS⁽¹⁾⁽²⁾

These seals incorporate a double-lip seal, a garter spring for maximum contact, and a heavy-duty steel shield that protects the seal from large pieces of debris that could damage the seal itself.

- **B Seal** – Made of nitrile rubber, this seal offers superior protection in applications with oil lubrication and is designed for extreme moisture, fine dust or extremely dirty applications. When using this seal, the housing comes with a vent fitting.
- **C Seal** – Made of DuPont Viton, this seal provides excellent chemical and abrasion resistance and can operate at higher temperatures than nitrile rubber. When using this seal, the housing comes with a vent fitting.

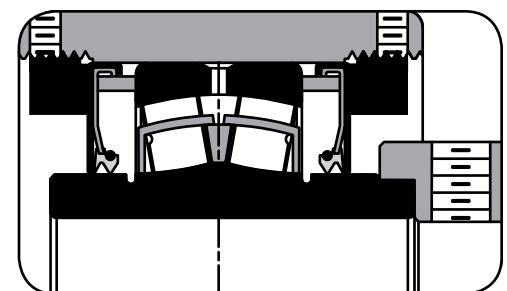

Fig. 27. Double-lip seals.

⁽¹⁾Temperature limit -40° C to 121° C (-40° F to 250° F) continuous, 149° C (300° F) intermittent. Constant seal-lip pressure on the inner ring results in higher operating temperatures of the complete unit. (See pages 31 and 32).

⁽²⁾Relief valve is standard.

DuPont™ is a trademark of E.I. du Pont de Nemours and Company. Teflon® is a registered trademark of E.I. du Pont de Nemours and Company. Viton® is a registered trademark of E.I. du Pont de Nemours and Company.

SECONDARY SEALS

In many circumstances, bearings become damaged in housed units due to premature primary seal wear. This is usually the result of harsh operating environments or lubrication issues. Timken offers secondary sealing options that provide an additional barrier to protect the primary seal. These economical secondary seals and covers are easily outfitted on virtually all solid-block housed units.

STEEL COVERS

Labyrinth Seals – Non-Contacting, Non-Purging, All Speeds

A labyrinth seal uses a winding passageway to accomplish a reduction in flow instead of trying to form a seal with a single strong barrier. Seal friction and wear is reduced.

- T Seal** – This seal, which is used in the open-end steel covers, consists of a DuPont Teflon ring pressed onto the shaft that floats between two pieces of formed steel to accommodate misalignment. Developed for higher-speed applications involving dirty conditions or moisture-affected areas, it is able to operate at higher temperatures and is impervious to most chemicals, while avoiding shaft damage.

URETHANE COVERS

DR Triple-Lip Secondary Seal – low speeds

The DR seal is the standard triple-lip seal adapted for use on the open-end covers and piloted flange cartridge backing plates (HSY). This seal can move within the cover or backing plate opening to accommodate misalignment while maintaining full contact to the shaft for positive sealing.

VR V-Ring Secondary Seal – high speeds

The VR seal, made of nitrile rubber, rides on the shaft and seals against the open-end covers and flange block backing plates (UFP).

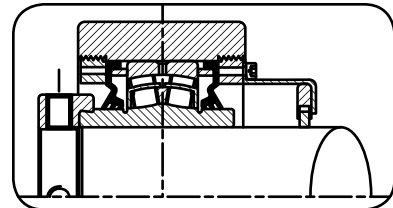

Fig. 28. Open-end steel cover with T seal.

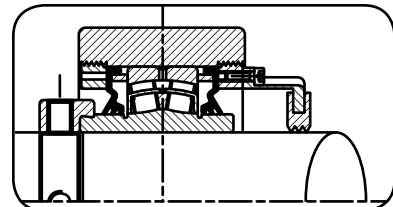

Fig. 29. Open-end urethane cover with DR seal.

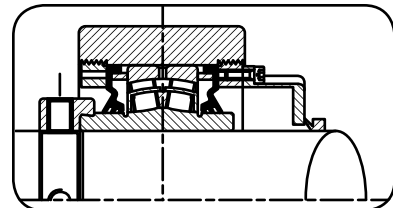

Fig. 30. Open-end urethane cover with VR seal.

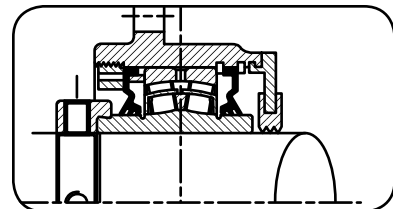

Fig. 31. HSY backing plate with DR seal.

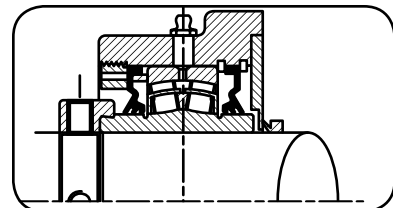

Fig. 32. UFP backing plate with VR seal.

STEEL AUXILIARY COVERS

Steel auxiliary covers bolt directly onto spherical roller bearing solid-block housed units. A DuPont Teflon labyrinth seal on the open-ended covers guards against shaft damage and gives protection at high running speeds. Made from steel to withstand the toughest applications, the covers are black-oxide treated for improved corrosion protection.

These covers are available in both open-ended and closed-ended designs for standard and custom configurations of Timken spherical roller bearing solid-block housed units.

Closed-End Covers (CS)

These bolt-on covers are designed to be virtually indestructible and extremely convenient. They are made from structural steel or urethane and are easy to install. The cover completely seals the bearing, preventing contamination from reaching the primary seal. Every cover is outfitted with a grease fitting to fill the cover cavity for an added barrier against contamination.



Fig. 33. Closed-end covers.

Open-End Covers (CJ/CK/CV)

These bolt-on covers are made from structural steel or urethane for repeated and continuous use. The covers are used with either a DuPont Teflon (T seal), triple-lip seal (DR) or a V-ring seal (VR) to help prevent contamination from reaching the primary seal. Every cover is outfitted with a grease fitting to fill the cover cavity for an added barrier against contamination.



Fig. 34. Open-end covers.

PILOTED FLANGE CARTRIDGE BACKING PLATES (HSY)

The HSY backing plate is designed to work in conjunction with the piloted flange cartridge housed units. Made of structural urethane, these plates are fitted to the back side of the pilot for extra protection. The HSY plate comes supplied with a triple-lip seal (DR) or a contamination collar (optional) to form an additional barrier against contamination for the most demanding applications.



Fig. 35. Piloted flange cartridge backing plates.

FLANGE BLOCK BACKING PLATES (UFP)

These backing plates are made from structural urethane and are uniquely designed to work with our flange block housed units. Made to fit flush against the back of the housing, these plates create a labyrinth over the inner ring for additional contamination protection. The UFP plate, when used with an optional V-ring seal (VR), provides an extra barrier against extreme contamination.



Fig. 36. Flange block backing plates.

HIGH-PERFORMANCE STEEL BACKING PLATE (BP)

These backing plates are made from mild steel and are uniquely designed to fit with our square flange block housed units. These plates use dual Teflon seals to make 360° contact on the shaft to eliminate contamination into the flange side of the housing. The plate is placed on the shaft prior to mounting the flange block and mounts flush with the back of the housing secured by the mounting bolts.



Fig. 37. High-performance steel backing plates.

STEEL COVER DIMENSIONS

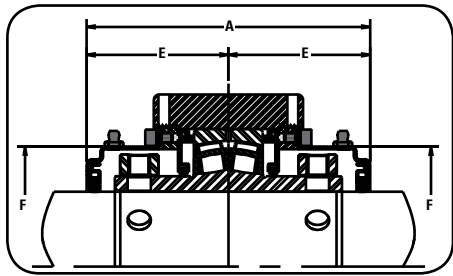

Fig. 38. Double open-end cover.⁽¹⁾

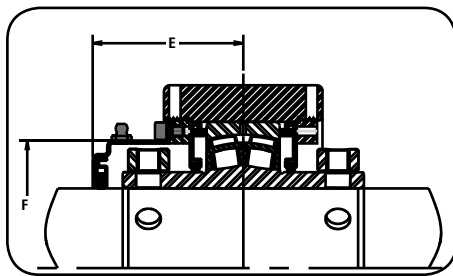

Fig. 39. Single open-end cover.

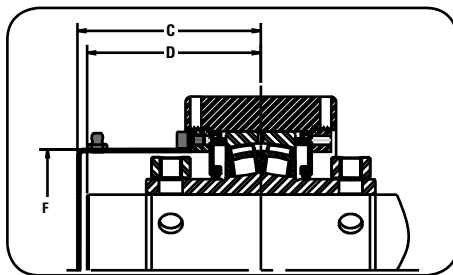

Fig. 40. Single closed-end cover.

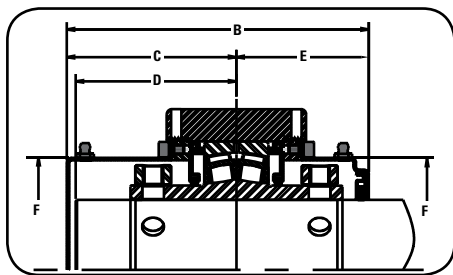

Fig. 41. Single closed-end cover and single open-end cover.⁽¹⁾

TABLE 34. V-LOCK® SERIES—STRAIGHT BORE EQUIVALENTS

Cover Part No.	Shaft Dia.	Bearing No.	Steel Cover Dimensions											
			A	B	C	D	E	F						
	mm in.		mm in.	mm in.	mm in.	mm in.	mm in.	mm in.						
CS11STEEL	CLOSED													
CV11T115S	1 15/16 in.	22211	128.5	143.3	79.2	75.2	64.3	89.7						
CV11T050S	50 mm		5.06	5.64	3.12	2.96	2.53	3.53						
CV11T200S	2 in.													
CS12STEEL	CLOSED													
CV12T055S	55 mm	22212	129.0	141.5	77.0	72.9	64.5	98.6						
CV12T203S	2 3/16 in.		5.08	5.57	3.03	2.87	2.54	3.88						
CV12T204S	2 1/4 in.													
CS14STEEL	CLOSED													
CV14T060S	60 mm	22214	135.4	159.3	91.4	87.4	67.8	103.6						
CV14T207S	2 7/16 in.		5.33	6.27	3.60	3.44	2.67	4.08						
CV14T208S	2 1/2 in.													
CV14T065S	65 mm													
CS16STEEL	CLOSED													
CV16T211S	2 11/16 in.	22216	150.1	167.6	92.5	88.4	75.2	116.1						
CV16T212S	2 3/4 in.								5.91	6.60	3.64	3.48	2.96	4.57
CV16T070S	70 mm													
CV16T215S	2 15/16 in.													
CV16T075S	75 mm													
CV16T300S	3 in.													
CS19STEEL	CLOSED													
CV19T080S	80 mm	22219	167.9	191.0	106.9	102.9	84.1	139.4						
CV19T303S	3 3/16 in.								6.61	7.52	4.21	4.05	3.31	5.49
CV19T304S	3 1/4 in.													
CV19T085S	85 mm													
CV19T307S	3 7/16 in.													
CV19T308S	3 1/2 in.													
CV19T090S	90 mm													
CS22STEEL	CLOSED													
CV22T311S	3 11/16 in.	22222	217.7	241.8	133.1	129.0	109.0	180.1						
CV22T312S	3 3/4 in.								8.57	9.52	5.24	5.08	4.29	7.09
CV22T100S	100 mm													
CV22T315S	3 15/16 in.													
CV22T400S	4 in.													
CS26STEEL	CLOSED													
CV26T110S	110 mm	22226	219.7	242.8	133.1	129.0	110.0	209.3						
CV26T407S	4 7/16 in.								8.65	9.56	5.24	5.08	4.33	8.24
CV26T408S	4 1/2 in.													
CV26T115S	115 mm													
CS28STEEL	CLOSED													
CV28T125S	125 mm	22228	223.5	246.9	135.1	131.1	111.8	209.3						
CV28T415S	4 15/16 in.								8.80	9.72	5.32	5.16	4.40	8.24
CV28T500S	5 in.													
CV28T130S	130 mm													

⁽¹⁾Double covers available only on pillow block and take-up style bearings.

TABLE 35. V-LOCK SERIES – TAPERED BORE EQUIVALENTS

Cover Part No.	Shaft Dia.	Bearing No.	Steel Cover Dimensions					
			A	B	C	D	E	F
	mm in.		mm in.	mm in.	mm in.	mm in.	mm in.	mm in.
CS11STEEL	CLOSED	22211	124.2 4.89	139.2 5.48	77.0 3.03	72.9 2.87	62.2 2.45	89.7 3.53
CV11T115S	1 15/16 in.							
CV11T050S	50 mm							
CV11T200S	2 in.							
CS13STEEL	CLOSED	22213	130.3 5.13	154.2 6.07	88.9 3.50	84.8 3.34	65.3 2.57	103.6 4.08
CV13T055S	55 mm							
CV13T203S	2 3/16 in.							
CV13T204S	2 1/4 in.							
CS15STEEL	CLOSED	22215	142.7 5.62	160.3 6.31	88.9 3.50	84.8 3.34	71.4 2.81	116.1 4.57
CV15T060S	60 mm							
CV15T207S	2 7/16 in.							
CV15T208S	2 1/2 in.							
CS17STEEL	CLOSED	22217	133.9 5.27	156.0 6.14	88.9 3.50	84.8 3.34	67.1 2.64	132.1 5.2
CV17T211S	2 11/16 in.							
CV17T212S	2 3/4 in.							
CV17T070S	70 mm							
CV17T215S	2 15/16 in.	22219	170.4 6.71	193.0 7.60	108.0 4.25	103.9 4.09	85.3 3.36	160.3 6.31
CV17T075S	75 mm							
CV17T300S	3 in.							
CS20STEEL	CLOSED							
CV20T080S	80 mm	22220	170.4 6.71	193.0 7.60	108.0 4.25	103.9 4.09	85.3 3.36	160.3 6.31
CV20T303S	3 3/16 in.							
CV20T304S	3 1/4 in.							
CV20T085S	85 mm							
CV20T307S	3 7/16 in.	22222	208.5 8.21	232.9 9.17	128.5 5.06	124.5 4.90	104.4 4.11	180.1 7.09
CV20T308S	3 1/2 in.							
CV20T090S	90 mm							
CS22STEEL	CLOSED							
CV22T311S	3 11/16 in.	22224	213.6 8.41	237.7 9.36	131.1 5.16	127.0 5.00	106.7 4.20	180.1 7.09
CV22T312S	3 3/4 in.							
CV22T100S	100 mm							
CV22T315S	3 15/16 in.							
CV22T400S	4 in.	22226	210.6 8.29	233.9 9.21	128.5 5.06	124.5 4.90	105.4 4.15	209.3 8.24
CS24STEEL	CLOSED							
CV24T110S	110 mm							
CS26STEEL	CLOSED							
CV26T110S	110 mm	22228	214.6 8.45	238.0 9.37	130.6 5.14	126.5 4.98	107.2 4.22	209.3 8.24
CV26T407S	4 7/16 in.							
CV26T408S	4 1/2 in.							
CV26T115S	115 mm							
CS28STEEL	CLOSED	22222	217.7 8.57	241.8 9.52	133.1 5.24	129.0 5.08	109.0 4.29	180.1 7.09
CV28T125S	125 mm							
CV28T415S	4 15/16 in.							
CV28T500S	5 in.							
CV28T130S	130 mm	22226	219.7 8.65	242.8 9.56	133.1 5.24	129.0 5.08	110.0 4.33	209.3 8.24
CS26STEEL	CLOSED							
CA26T125S	125 mm							
CA26T415S	4 15/16 in.							
CA26T500S	5 in.	22226	219.7 8.65	242.8 9.56	133.1 5.24	129.0 5.08	110.0 4.33	209.3 8.24
CA26T130S	130 mm							

TABLE 36. CL SERIES – SINGLE AND DOUBLE SET SCREW LOCKS

Cover Part No.	Shaft Dia.	Bearing No.	Steel Cover Dimensions					
			A	B	C	D	E	F
	mm in.		mm in.	mm in.	mm in.	mm in.	mm in.	mm in.
CS08STEEL	CLOSED	22208	115.6 4.55	127.8 5.03	69.9 2.75	65.8 2.59	57.9 2.28	69.6 2.74
CA08T035S	35 mm							
CA08T107S	1 7/16 in.							
CA08T108S	1 1/2 in.							
CS09STEEL	CLOSED	22209	121.7 4.79	130.8 5.15	69.9 2.75	65.8 2.59	61.0 2.40	74.7 2.94
CA09T040S	40 mm							
CA09T111S	1 11/16 in.							
CA09T112S	1 3/4 in.							
CA09T045S	45 mm	22210	122.7 4.83	132.8 5.23	73.2 2.88	69.1 2.72	61.5 2.42	79.8 3.14
CS10STEEL	CLOSED							
CA10T115S	1 15/16 in.							
CA10T050S	50 mm							
CA10T200S	2 in.	22211	128.5 5.06	143.3 5.64	79.2 3.12	75.2 2.96	64.3 2.53	89.7 3.53
CS11STEEL	CLOSED							
CA11T055S	55 mm							
CA11T203S	2 3/16 in.							
CA11T204S	2 1/4 in.	22213	135.4 5.33	159.3 6.27	91.4 3.60	87.4 3.44	67.8 2.67	103.6 4.08
CS13STEEL	CLOSED							
CA13T060S	60 mm							
CA13T207S	2 7/16 in.							
CA13T208S	2 1/2 in.	22215	148.1 5.83	165.6 6.52	91.4 3.60	87.4 3.44	74.2 2.92	116.1 4.57
CA13T065S	65 mm							
CS15STEEL	CLOSED							
CA15T211S	2 11/16 in.							
CA15T212S	2 3/4 in.	22218	164.8 6.49	188.0 7.40	105.7 4.16	101.6 4.00	82.6 3.25	139.4 5.49
CA15T070S	70 mm							
CA15T215S	2 15/16 in.							
CA15T075S	75 mm							
CA15T300S	3 in.	22220	179.6 7.07	202.2 7.96	112.5 4.43	108.5 4.27	89.9 3.54	160.3 6.31
CS18STEEL	CLOSED							
CA18T080S	80 mm							
CA18T303S	3 3/16 in.							
CA18T304S	3 1/4 in.	22222	217.7 8.57	241.8 9.52	133.1 5.24	129.0 5.08	109.0 4.29	180.1 7.09
CA18T085S	85 mm							
CA18T307S	3 7/16 in.							
CA18T308S	3 1/2 in.							
CA18T090S	90 mm	22226	219.7 8.65	242.8 9.56	133.1 5.24	129.0 5.08	110.0 4.33	209.3 8.24
CS20STEEL	CLOSED							
CA20T311S	3 11/16 in.							
CA20T312S	3 3/4 in.							
CA20T100S	100 mm	22222	217.7 8.57	241.8 9.52	133.1 5.24	129.0 5.08	109.0 4.29	180.1 7.09
CA20T315S	3 15/16 in.							
CA20T400S	4 in.							
CS22STEEL	CLOSED							
CA22T110S	110 mm	22222	217.7 8.57	241.8 9.52	133.1 5.24	129.0 5.08	109.0 4.29	180.1 7.09
CA22T407S	4 7/16 in.							
CA22T408S	4 1/2 in.							
CA22T115S	115 mm							
CS26STEEL	CLOSED	22226	219.7 8.65	242.8 9.56	133.1 5.24	129.0 5.08	110.0 4.33	209.3 8.24
CA26T125S	125 mm							
CA26T415S	4 15/16 in.							
CA26T500S	5 in.							
CA26T130S	130 mm	22226	219.7 8.65	242.8 9.56	133.1 5.24	129.0 5.08	110.0 4.33	209.3 8.24
CA26T130S	130 mm							

TABLE 37. EC SERIES—ECCENTRIC LOCK

Cover Part No.	Shaft Dia.	Bearing No.	Steel Cover Dimensions					
			A	B	C	D	E	F
	mm in.		mm in.	mm in.	mm in.	mm in.	mm in.	mm in.
CS08STEEL	CLOSED							
CJ08T035S	35 mm	22208	115.6 4.55	127.8 5.03	69.9 2.75	65.8 2.59	57.9 2.28	69.6 2.74
CJ08T107S	1 7/16 in.							
CJ08T108S	1 1/2 in.							
CS09STEEL	Closed							
CJ09T040S	40 mm	22209	121.7 4.79	130.8 5.15	69.9 2.75	65.8 2.59	61.0 2.40	74.7 2.94
CJ09T111S	1 11/16 in.							
CJ09T112S	1 3/4 in.							
CJ09T045S	45 mm							
CS10STEEL	CLOSED							
CJ10T115S	1 15/16 in.	22210	122.7 4.83	132.8 5.23	73.2 2.88	69.1 2.72	61.5 2.42	79.8 3.14
CJ10T050S	50 mm							
CJ10T200S	2 in.							
CS11STEEL	CLOSED							
CJ11T055S	55 mm	22211	128.5 5.06	143.3 5.64	79.2 3.12	75.2 2.96	64.3 2.53	89.7 3.53
CJ11T203S	2 3/16 in.							
CJ11T204S	2 1/4 in.							
CS13STEEL	CLOSED							
CJ13T060S	60 mm	22213	135.4 5.33	159.3 6.27	91.4 3.60	87.4 3.44	67.8 2.67	103.6 4.08
CJ13T207S	2 7/16 in.							
CJ13T208S	2 1/2 in.							
CJ13T065S	65 mm							
CS15STEEL	CLOSED							
CJ15T211S	2 11/16 in.	22215	148.1 5.83	165.6 6.52	91.4 3.60	87.4 3.44	74.2 2.92	116.1 4.57
CJ15T212S	2 3/4 in.							
CJ15T070S	70 mm							
CJ15T215S	2 15/16 in.							
CJ15T075S	75 mm							
CJ15T300S	3 in.							
CS18STEEL	CLOSED							
CJ18T080S	80 mm	22218	164.8 6.49	188.0 7.40	105.7 4.16	101.6 4.00	82.6 3.25	139.4 5.49
CJ18T303S	3 3/16 in.							
CJ18T304S	3 1/4 in.							
CJ18T085S	85 mm							
CJ18T307S	3 7/16 in.							
CJ18T308S	3 1/2 in.							
CJ18T090S	90 mm							

Cover Part No.	Shaft Dia.	Bearing No.	Steel Cover Dimensions					
			A	B	C	D	E	F
	mm in.		mm in.	mm in.	mm in.	mm in.	mm in.	mm in.
CS20STEEL	CLOSED							
CJ20T311S	3 11/16 in.	22220	179.6 7.07	202.2 7.96	112.5 4.43	108.5 4.27	89.9 3.54	160.3 6.31
CJ20T312S	3 3/4 in.							
CJ20T100S	100 mm							
CJ20T315S	3 15/16 in.							
CJ20T400S	4 in.							
CS22STEEL	CLOSED							
CJ22T110S	110 mm	22222	217.7 8.57	241.8 9.52	133.1 5.24	129.0 5.08	109.0 4.29	180.1 7.09
CJ22T407S	4 7/16 in.							
CJ22T408S	4 1/2 in.							
CJ22T115S	115 mm							
CS26STEEL	CLOSED							
CJ26T125S	125 mm	22226	219.7 8.65	242.8 9.56	133.1 5.24	129.0 5.08	110.0 4.33	209.3 8.24
CJ26T415S	4 15/16 in.							
CJ26T500S	5 in.							
CJ26T130S	130 mm							
CS30STEEL	CLOSED							
CJ30T507S	5 7/16 in.	23230	270.3 10.64	283.2 11.15	148.1 5.83	144.0 5.67	135.1 5.32	239.5 9.43
CJ30T508S	5 1/2 in.							
CJ30T140S	140 mm							
CJ30T515S	5 15/16 in.							
CJ30T600S	6 in.							
CJ30T150S	150 mm							
CS34STEEL	CLOSED							
CJ34T607S	6 7/16 in.	23234	300.5 11.83	305.3 12.02	155.2 6.11	151.1 5.95	150.1 5.91	279.4 11.00
CJ34T608S	6 1/2 in.							
CJ34T170S	170 mm							
CJ34T615S	6 15/16 in.							
CJ34T700S	7 in.							
CJ34T180S	180 mm							

TABLE 38. TA/DV SERIES – TAPERED ADAPTER LOCK

Cover Part No.	Shaft Dia.	Bearing No.	Steel Cover Dimensions					
			A	B	C	D	E	F
	mm in.		mm in.	mm in.	mm in.	mm in.	mm in.	mm in.
CS09STEEL	CLOSED							
CK09T107S	1 7/16 in.	22209	118.4	127.5	68.3	64.3	59.2	74.7
CK09T108S	1 1/2 in.		4.66	5.02	2.69	2.53	2.33	2.94
CK09T040S	40 mm							
CS10STEEL	CLOSED							
CK10T111S	1 11/16 in.	22210	118.4	130.0	70.9	66.8	59.2	79.8
CK10T112S	1 3/4 in.		4.66	5.12	2.79	2.63	2.33	3.14
CK10T045S	45 mm							
CS11STEEL	CLOSED							
CK11T115S	1 15/16 in.	22211	124.2	139.2	77.0	72.9	62.2	89.7
CK11T050S	50 mm		4.89	5.48	3.03	2.87	2.45	3.53
CK11T200S	2 in.							
CS12STEEL	CLOSED							
CK12T055S	55 mm	22212	123.7	136.4	74.4	70.4	62.0	98.6
CK12T055S	55 mm		4.87	5.37	2.93	2.77	2.44	3.88
CS13STEEL	CLOSED							
CK13T203S	2 3/16 in.	22213	130.3	154.2	88.9	84.8	65.3	103.6
CK13T204S	2 1/4 in.		5.13	6.07	3.50	3.34	2.57	4.08
CK13T060S	60 mm							
CS15STEEL	CLOSED							
CK15T207S	2 7/16 in.	22215	142.7	160.3	88.9	84.8	71.4	116.1
CK15T208S	2 1/2 in.		5.62	6.31	3.50	3.34	2.81	4.57
CK15T065S	65 mm							
CS16STEEL	CLOSED							
CK16T211S	2 11/16 in.	22216	144.8	162.3	89.9	85.9	72.4	116.1
CK16T212S	2 3/4 in.		5.70	6.39	3.54	3.38	2.85	4.57
CK16T070S	70 mm							
CS17STEEL	CLOSED							
CK17T215S	2 15/16 in.	22217	133.9	156.0	88.9	84.8	67.1	132.1
CK17T075S	75 mm		5.27	6.14	3.50	3.34	2.64	5.20
CK17T300S	3 in.							
CS18STEEL	CLOSED							
CK18T080S	80 mm	22218	159.5	182.9	102.9	98.8	79.8	139.4
CK18T303S	3 3/16 in.		6.28	7.20	4.05	3.89	3.14	5.49
CK18T304S	3 1/4 in.							
CS19STEEL	CLOSED							
CK19T085S	85 mm	22219	162.6	185.7	104.4	100.3	81.3	139.4
CK19T085S	85 mm		6.40	7.31	4.11	3.95	3.20	5.49
CS20STEEL	CLOSED							
CK20T307S	3 7/16 in.	22220	170.4	193.0	108.0	103.9	85.3	160.3
CK20T308S	3 1/2 in.		6.71	7.60	4.25	4.09	3.36	6.31
CK20T090S	90 mm							
CS22STEEL	CLOSED							
CK22T315S	3 15/16 in.	22222	208.5	232.9	128.5	124.5	104.4	180.1
CK22T400S	4 in.		8.21	9.17	5.06	4.90	4.11	7.09
CK22T100S	100 mm							
CS24STEEL	CLOSED							
CK24T403S	4 3/16 in.	22224	213.6	237.7	131.1	127.0	106.7	180.1
CK24T404S	4 1/4 in.		8.41	9.36	5.16	5.00	4.20	7.09
CK24T110S	110 mm							
CS26STEEL	CLOSED							
CK26T407S	4 7/16 in.	22226	210.6	233.9	128.5	124.5	105.4	209.3
CK26T408S	4 1/2 in.		8.29	9.21	5.06	4.90	4.15	8.24
CK26T115S	115 mm							
CS28STEEL	CLOSED							
CK28T415S	4 15/16 in.	22228	214.6	238.0	130.6	126.5	107.2	209.3
CK28T500S	5 in.		8.45	9.37	5.14	4.98	4.22	8.24
CK28T125S	125 mm							

URETHANE

CLOSED-END COVER DIMENSIONS

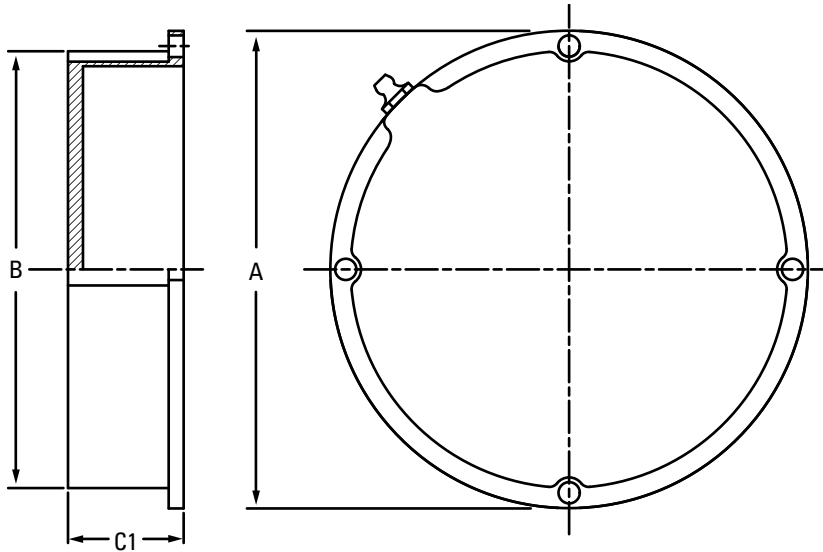

TABLE 39. CLOSED-END COVER DIMENSIONS

Cover Part No. ⁽¹⁾	A	B	C1 ⁽²⁾
	mm in.	mm in.	mm in.
CS08	97.0 3.82	76.7 3.02	31.8 1.25
CS09	101.8 4.01	81.5 3.21	31.8 1.25
CS10	106.9 4.21	86.6 3.41	31.8 1.25
CS11	117.1 4.61	96.8 3.81	31.8 1.25
CS12V	126.0 4.96	105.7 4.16	31.8 1.25
CS13/CS14V	132.1 5.20	116.1 4.57	31.8 1.08
CS15/CS16V	142.0 5.59	122.9 4.84	33.0 1.30
CS17	160.5 6.32	141.5 5.57	31.0 1.22
CS18/CS19V	168.1 6.62	149.1 5.87	38.9 1.53
CS20	192.0 7.56	174.7 6.88	44.5 1.75
CS22	212.1 8.35	194.8 7.67	52.6 2.07
CS24	212.1 8.35	194.8 7.67	52.6 2.07
CS26/CS28V	241.3 9.50	223.8 8.81	56.9 2.24
CS30	271.5 10.69	254.0 10.00	56.9 2.24
CS34	304.8 12.00	287.3 11.31	56.9 2.24

⁽¹⁾Cover part number, CSXX, is determined by the bearing insert series of unit on which cover will be installed. See nomenclature guide on page 62 to determine bearing insert series.

⁽²⁾Extended covers available upon request.

OPEN-END COVERS WITH DR SEALS

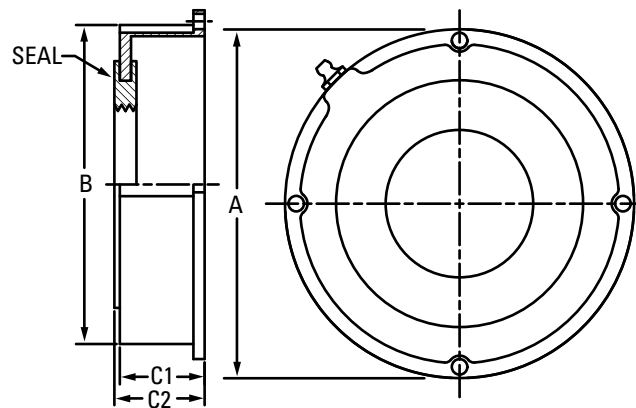

TABLE 40. V-LOCK SERIES – STRAIGHT BORE EQUIVALENT – OPEN-END COVER WITH DR SEAL – (QV[V]...P, PL, SN, PF, PR, C, CW, F, FL, FY, FX, TU)

Cover Part No.	Shaft Dia.	A	B	C1	C2
	mm in.	mm in.	mm in.	mm in.	mm in.
CVDR11-115	1 15/16 in.	117.1 4.61	96.8 3.81	31.8 1.25	34.3 1.35
CVDR11-200	2 in.				
CVDR11-050MM	50 mm	126.0 4.96	105.7 4.16	31.8 1.25	34.3 1.35
CVDR12-203	2 3/16 in.				
CVDR12-204	2 1/4 in.	126.0 4.96	105.7 4.16	31.8 1.25	34.3 1.35
CVDR12-055MM	55 mm				
CVDR14-060MM	60 mm	132.1 5.20	116.1 4.57	27.4 1.08	30.0 1.18
CVDR14-207	2 7/16 in.				
CVDR14-208	2 1/2 in.	132.1 5.20	116.1 4.57	27.4 1.08	30.0 1.18
CVDR14-065MM	65 mm				
CVDR16-211	2 11/16 in.	142.0 5.59	122.9 4.84	33.0 1.30	35.6 1.40
CVDR16-212	2 3/4 in.				
CVDR16-070MM	70 mm	142.0 5.59	122.9 4.84	33.0 1.30	35.6 1.40
CVDR16-215	2 15/16 in.				
CVDR16-300	3 in.	142.0 5.59	122.9 4.84	33.0 1.30	35.6 1.40
CVDR16-075MM	75 mm				
CVDR19-303	3 3/16 in.	168.1 6.62	149.1 5.87	38.9 1.53	41.4 1.63
CVDR19-304	3 1/4 in.				
CVDR19-080MM	80 mm	168.1 6.62	149.1 5.87	38.9 1.53	41.4 1.63
CVDR19-085MM	85 mm				
CVDR19-307	3 7/16 in.	168.1 6.62	149.1 5.87	38.9 1.53	41.4 1.63
CVDR19-308	3 1/2 in.				
CVDR19-090MM	90 mm	212.1 8.35	194.8 7.67	52.6 2.07	55.1 2.17
CVDR22-311	3 11/16 in.				
CVDR22-312	3 3/4 in.	212.1 8.35	194.8 7.67	52.6 2.07	55.1 2.17
CVDR22-100MM	100 mm				
CVDR22-315	3 15/16 in.	212.1 8.35	194.8 7.67	52.6 2.07	55.1 2.17
CVDR22-400	4 in.				
CVDR26-110MM	110 mm	241.3 9.50	223.8 8.81	56.9 2.24	59.4 2.34
CVDR26-407	4 7/16 in.				
CVDR26-408	4 1/2 in.	241.3 9.50	223.8 8.81	56.9 2.24	59.4 2.34
CVDR26-115MM	115 mm				
CVDR28-125MM	125 mm	241.3 9.50	223.8 8.81	56.9 2.24	59.4 2.34
CVDR28-415	4 15/16 in.				
CVDR28-500	5 in.	241.3 9.50	223.8 8.81	56.9 2.24	59.4 2.34
CVDR28-130MM	130 mm				

TABLE 41. V-LOCK SERIES – TAPERED ADAPTER EQUIVALENT – OPEN-END COVER WITH DR SEAL – (QV[V]...PA, PN, PKT, PK, PH, PG, FC, FB, MC)

Cover Part No.	Shaft Dia.	A	B	C1	C2
	mm in.	mm in.	mm in.	mm in.	mm in.
CVDR11-115	1 15/16 in.	117.1 4.61	96.8 3.81	31.8 1.25	34.3 1.35
CVDR11-200	2 in.				
CVDR11-050MM	50 mm	132.1 5.20	116.1 4.57	27.4 1.08	30.0 1.18
CVDR13-203	2 3/16 in.				
CVDR13-204	2 1/4 in.	132.1 5.20	116.1 4.57	27.4 1.08	30.0 1.18
CVDR13-055MM	55 mm				
CVDR15-060MM	60 mm	142.0 5.59	122.9 4.84	33.0 1.30	35.6 1.40
CVDR15-207	2 7/16 in.				
CVDR15-208	2 1/2 in.	142.0 5.59	122.9 4.84	33.0 1.30	35.6 1.40
CVDR15-065MM	65 mm				
CVDR17-211	2 11/16 in.	160.5 6.32	141.5 5.57	31.0 1.22	33.5 1.32
CVDR17-212	2 3/4 in.				
CVDR17-070MM	70 mm	160.5 6.32	141.5 5.57	31.0 1.22	33.5 1.32
CVDR17-215	2 15/16 in.				
CVDR17-300	3 in.	160.5 6.32	141.5 5.57	31.0 1.22	33.5 1.32
CVDR16-075MM	75 mm				
CVDR20-303	3 3/16 in.	192.0 7.56	174.8 6.88	44.5 1.75	47.0 1.85
CVDR20-304	3 1/4 in.				
CVDR20-080MM	80 mm	192.0 7.56	174.8 6.88	44.5 1.75	47.0 1.85
CVDR20-085MM	85 mm				
CVDR20-307	3 7/16 in.	192.0 7.56	174.8 6.88	44.5 1.75	47.0 1.85
CVDR19-308	3 1/2 in.				
CVDR19-090MM	90 mm	212.1 8.35	194.8 7.67	52.6 2.07	55.1 2.17
CVDR22-311	3 11/16 in.				
CVDR22-312	3 3/4 in.	212.1 8.35	194.8 7.67	52.6 2.07	55.1 2.17
CVDR22-100MM	100 mm				
CVDR22-315	3 15/16 in.	212.1 8.35	194.8 7.67	52.6 2.07	55.1 2.17
CVDR22-400	4 in.				
CVDR26-110MM	110 mm	241.3 9.50	223.8 8.81	56.9 2.24	59.4 2.34
CVDR26-407	4 7/16 in.				
CVDR26-408	4 1/2 in.	241.3 9.50	223.8 8.81	56.9 2.24	59.4 2.34
CVDR26-115MM	115 mm				
CVDR28-125MM	125 mm	241.3 9.50	223.8 8.81	56.9 2.24	59.4 2.34
CVDR28-415	4 15/16 in.				
CVDR28-500	5 in.	241.3 9.50	223.8 8.81	56.9 2.24	59.4 2.34
CVDR28-130MM	130 mm				

SEAL AND COVER OPTIONS

TABLE 42. CL AND EC SERIES—OPEN-END COVER WITH DR SEAL

Cover Part No.	Shaft Dia.	A	B	C1	C2
	mm in.	mm in.	mm in.	mm in.	mm in.
CJDR035MM	35 mm				
CJDR107	1 7/16 in.	97.0	76.7	31.8	34.3
CJDR108	1 1/2 in.	3.82	3.02	1.25	1.35
CJDR040MM	40 mm				
CJDR111	1 11/16 in.	101.9	81.6	31.8	34.3
CJDR112	1 3/4 in.	4.01	3.21	1.25	1.35
CJDR045MM	45 mm				
CJDR115	1 15/16 in.	106.9	86.6	31.8	34.3
CJDR200	2 in.	4.21	3.41	1.25	1.35
CJDR050MM	50 mm				
CJDR203	2 3/16 in.	117.1	96.8	31.8	34.3
CJDR204	2 1/4 in.	4.61	3.81	1.25	1.35
CJDR055MM	55 mm				
CJDR060MM	60 mm				
CJDR207	2 7/16 in.	132.1	116.1	27.4	30.0
CJDR208	2 1/2 in.	5.20	4.57	1.08	1.18
CJDR065MM	65 mm				
CJDR211	2 11/16 in.				
CJDR070MM	70 mm				
CJDR212	2 3/4 in.	142	122.9	33.0	35.6
CJDR215	2 15/16 in.	5.59	4.84	1.30	1.40
CJDR300	3 in.				
CJDR075MM	75 mm				
CJDR303	3 3/16 in.				
CJDR304	3 1/4 in.				
CJDR080MM	80 mm	168.1	149.1	38.9	41.4
CJDR085MM	85 mm	6.62	5.87	1.53	1.63
CJDR307	3 7/16 in.				
CJDR308	3 1/2 in.				
CJDR090MM	90 mm				
CJDR315	3 15/16 in.	192	174.8	44.5	47.0
CJDR400	4 in.	7.56	6.88	1.75	1.85
CJDR100MM	100 mm				
CJDR110MM	110 mm				
CJDR407	4 7/16 in.	212.1	194.8	52.6	55.1
CJDR408	4 1/2 in.	8.35	7.67	2.07	2.17
CJDR115MM	115 mm				
CJDR125MM	125 mm				
CJDR415	4 15/16 in.	241.3	223.8	56.9	59.4
CJDR500	5 in.	9.50	8.81	2.24	2.34
CJDR130MM	130 mm				
CJDR507	5 7/16 in.				
CJDR508	5 1/2 in.				
CJDR140MM	140 mm	271.6	254.0	56.9	59.4
CJDR515	5 15/16 in.	10.69	10.00	2.24	2.34
CJDR600	6 in.				
CJDR150MM	150 mm				
CJDR607	6 7/16 in.				
CJDR608	6 1/2 in.				
CJDR170MM	170 mm	304.8	287.3	56.9	59.4
CJDR615	6 15/16 in.	12.00	11.31	2.24	2.34
CJDR700	7 in.				
CJDR180MM	180 mm				

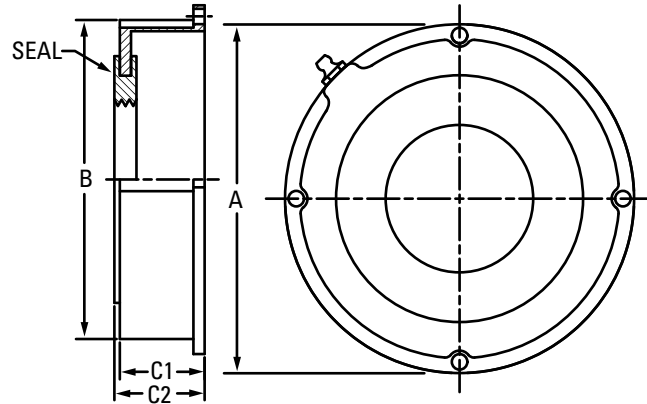

TABLE 43. TA/DV SERIES—OPEN-END COVER WITH DR SEAL

Cover Part No.	Shaft Dia.	A	B	C1	C2
	mm in.	mm in.	mm in.	mm in.	mm in.
CKDR107	1 7/16 in.	101.9	81.5	31.8	34.3
CKDR108	1 1/2 in.	4.01	3.21	1.25	1.35
CKDR040MM	40 mm				
CKDR111	1 11/16 in.	106.9	86.6	31.8	34.3
CKDR112	1 3/4 in.	4.21	3.41	1.25	1.35
CKDR045MM	45 mm				
CKDR115	1 15/16 in.	117.1	96.8	31.8	34.3
CKDR200	2 in.	4.61	3.81	1.25	1.35
CKDR050MM	50 mm				
CKDR055MM	55 mm	126.0	105.7	31.8	34.3
		4.96	4.16	1.25	1.35
CKDR203	2 3/16 in.	132.1	116.1	27.4	30.0
CKDR204	2 1/4 in.	5.20	4.57	1.08	1.18
CKDR060MM	60 mm				
CKDR207	2 7/16 in.	142.0	122.9	33.0	35.6
CKDR208	2 1/2 in.	5.59	4.84	1.30	1.40
CKDR065MM	65 mm				
CKDR211	2 11/16 in.	142.0	122.9	33.0	35.6
CKDR212	2 3/4 in.	5.59	4.84	1.30	1.40
CKDR070MM	70 mm				
CKDR215	2 15/16 in.	160.5	141.5	31.0	33.5
CKDR300	3 in.	6.32	5.57	1.22	1.32
CKDR075MM	75 mm				
CKDR080MM	80 mm				
CKDR303	3 3/16 in.	168.1	149.1	38.9	41.4
CKDR304	3 1/4 in.	6.62	5.87	1.53	1.63
CKDR085MM	85 mm	168.1	149.1	38.9	41.4
		6.62	5.87	1.53	1.63
CKDR307	3 7/16 in.	192.0	174.8	44.5	47.0
CKDR308	3 1/2 in.	7.56	6.88	1.75	1.85
CKDR090MM	90 mm				
CKDR315	3 15/16 in.	212.1	194.8	52.6	55.1
CKDR400	4 in.	8.35	7.67	2.07	2.17
CKDR100MM	100 mm				
CKDR403	4 3/16 in.	212.1	194.8	52.6	55.1
CKDR404	4 1/4 in.	8.35	7.67	2.07	2.17
CKDR110MM	110 mm				
CKDR407	4 7/16 in.	241.3	223.8	56.9	59.4
CKDR408	4 1/2 in.	9.50	8.81	2.24	2.34
CKDR115MM	115 mm				
CKDR415	4 15/16 in.	241.3	223.8	56.9	59.4
CKDR500	5 in.	9.50	8.81	2.24	2.34
CKDR125MM	125 mm				

OPEN-END COVERS WITH VR SEALS

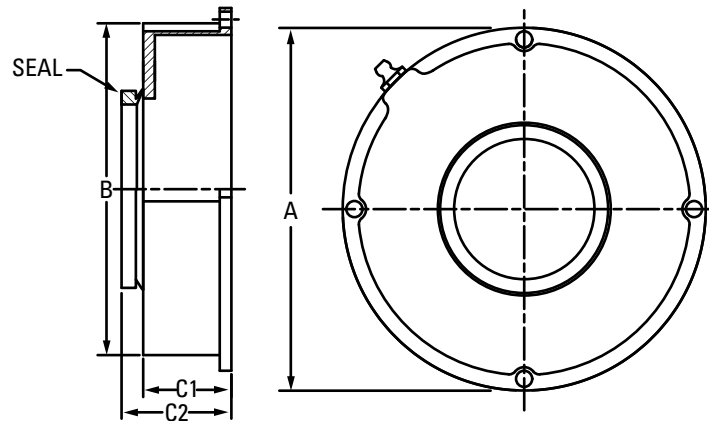

TABLE 44. V-LOCK SERIES – STRAIGHT BORE EQUIVALENT – OPEN-END COVER WITH VR SEAL – (QV[V])...P, PL, SN, PF, PR, PX, PXT, C, CW, F, FL, FY, FX, TU)

Cover Part No. ⁽¹⁾	Shaft Dia.	A	B	C1	C2
	mm in.	mm in.	mm in.	mm in.	mm in.
CVVR11	1 15/16 in.	117.1 4.61	96.8 3.81	31.8 1.25	40.6 1.60
	2 in.				
	50 mm				
CVVR12	2 3/16 in.	126.0 4.96	105.7 4.16	31.8 1.25	40.6 1.60
	2 1/4 in.				
	55 mm				
CVVR14	2 7/16 in.	132.1 5.20	116.1 4.57	27.4 1.08	36.3 1.43
	2 1/2 in.				
	65 mm				
CVVR16	2 11/16 in.	142.0 5.59	122.9 4.84	33.0 1.30	44.0 1.73
	2 3/4 in.				
	70 mm				
	2 15/16 in.				
CVVR19	3 in.	168.1 6.62	149.1 5.87	38.9 1.53	50.0 1.96
	75 mm				
	3 3/16 in.				
	3 1/4 in.				
	80 mm				
CVVR22	85 mm	212.1 8.35	194.8 7.67	52.6 2.07	63.5 2.50
	3 7/16 in.				
	3 1/2 in.				
	90 mm				
CVVR26	3 11/16 in.	241.3 9.50	223.8 8.81	56.9 2.24	69.6 2.74
	3 3/4 in.				
	100 mm				
	3 15/16 in.				
CVVR28	4 in.	241.3 9.50	223.8 8.81	56.9 2.24	69.6 2.74
	110 mm				
	4 7/16 in.				
CVVR26	4 1/2 in.	241.3 9.50	223.8 8.81	56.9 2.24	69.6 2.74
	115 mm				
	125 mm				
CVVR28	4 15/16 in.	241.3 9.50	223.8 8.81	56.9 2.24	69.6 2.74
	5 in.				
	130 mm				
	125 mm				

⁽¹⁾Please refer to bore size when choosing cover for straight-bore V-Lock®.

TABLE 45. V-LOCK SERIES – TAPERED ADAPTER EQUIVALENT – OPEN-END COVER WITH VR SEAL – (QV[V])...PA, PN, PKT, PK, PH, PG, FC, FB, MC)

Cover Part No.	Shaft Dia.	A	B	C1	C2
	mm in.	mm in.	mm in.	mm in.	mm in.
CKVR11	1 15/16 in.	117.1 4.61	96.8 3.81	31.8 1.25	40.6 1.60
	2 in.				
	50 mm				
CKVR13	2 3/16 in.	132.1 5.20	116.1 4.57	27.4 1.08	36.3 1.43
	2 1/4 in.				
	55 mm				
CKVR15	60 mm	142.0 5.59	122.9 4.84	33.0 1.30	41.9 1.65
	2 7/16 in.				
	2 1/2 in.				
CKVR17	65 mm	160.6 6.32	141.5 5.57	31.0 1.22	41.9 1.65
	2 11/16 in.				
	2 3/4 in.				
	70 mm				
CKVR20	2 15/16 in.	192.0 7.56	174.8 6.88	44.4 1.75	55.4 2.18
	3 in.				
	75 mm				
	3 3/16 in.				
	3 1/4 in.				
CKVR22	80 mm	212.1 8.35	194.8 7.67	52.6 2.07	63.5 2.50
	85 mm				
	3 7/16 in.				
	3 1/2 in.				
CKVR24	90 mm	212.1 8.35	194.8 7.67	52.6 2.07	63.5 2.5
	3 11/16 in.				
	3 3/4 in.				
	100 mm				
CKVR26	3 15/16 in.	241.3 9.50	223.8 8.81	56.9 2.24	69.6 2.74
	4 in.				
	110 mm				
CKVR28	4 7/16 in.	241.3 9.50	223.8 8.81	56.9 2.24	69.6 2.74
	4 1/2 in.				
	115 mm				
	125 mm				
CKVR28	4 15/16 in.	241.3 9.50	223.8 8.81	56.9 2.24	69.6 2.74
	5 in.				
	130 mm				
	125 mm				

SEAL AND COVER OPTIONS

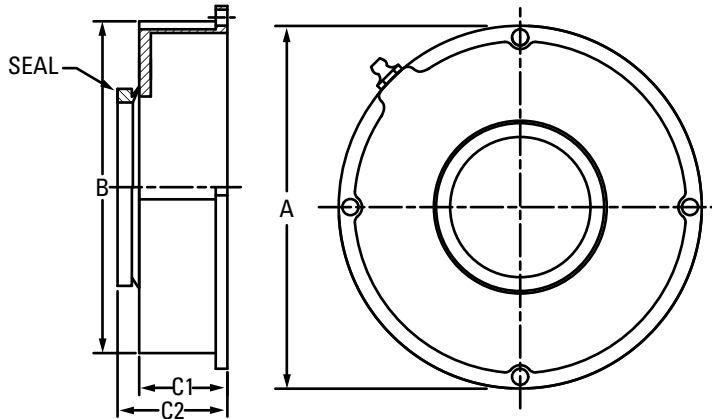

TABLE 46. CL AND EC SERIES—OPEN-END COVER WITH VR SEAL

Cover Part No.	Shaft Dia.	A	B	C1	C2
	mm in.	mm in.	mm in.	mm in.	mm in.
CJVR08	35 mm	97.0	76.7	31.8	39.4
	1 7/16 in.				
	1 1/2 in.				
CJVR09	40 mm	101.9	81.5	31.8	40.6
	1 11/16 in.				
	1 3/4 in.				
CJVR10	45 mm	106.9	86.6	31.8	40.6
	1 15/16 in.				
	2 in.				
CJVR11	50 mm	117.1	96.8	31.8	40.6
	2 3/16 in.				
	2 1/4 in.				
CJVR13	55 mm	132.1	116.1	27.4	36.3
	2 1/8 in.				
	2 1/2 in.				
CJVR15	60 mm	142.0	122.9	33.0	44.0
	2 3/8 in.				
	2 5/8 in.				
	3 in.				
	75 mm				
CJVR18	80 mm	168.1	149.1	38.9	49.8
	3 1/8 in.				
	3 1/4 in.				
	85 mm				
	3 7/16 in.				
CJVR20	90 mm	192.0	174.8	44.5	55.4
	3 5/8 in.				
	4 in.				
CJVR22	100 mm	212.1	194.8	52.6	65.3
	4 in.				
	4 1/2 in.				
CJVR26	110 mm	241.3	223.8	56.9	69.6
	4 3/8 in.				
	4 7/16 in.				

TABLE 47. TA/DV SERIES—OPEN-END COVER WITH VR SEAL

Cover Part No.	Shaft Dia.	A	B	C1	C2
	mm in.	mm in.	mm in.	mm in.	mm in.
CKVR09	1 7/16 in.	101.9	81.5	31.8	39.4
	1 1/2 in.				
	40 mm				
CKVR10	1 11/16 in.	106.9	86.6	31.8	40.6
	1 3/4 in.				
	45 mm				
CKVR11	1 15/16 in.	117.1	96.8	31.8	40.6
	2 in.				
	50 mm				
CKVR12	55 mm	126.0	105.7	31.8	40.6
	2 3/16 in.				
CKVR13	60 mm	132.1	116.1	27.4	36.3
	2 1/4 in.				
	60 mm				
CKVR15	65 mm	142.0	122.9	33.0	41.9
	2 7/16 in.				
	2 1/2 in.				
CKVR16	70 mm	142.0	122.9	33.0	41.9
	2 7/16 in.				
	2 3/4 in.				
CKVR17	75 mm	160.5	141.5	31.0	41.9
	2 15/16 in.				
	3 in.				
CKVR18	80 mm	168.1	149.1	38.9	49.8
	3 1/8 in.				
	3 1/4 in.				
CKVR19	85 mm	168.1	149.1	38.9	49.8
	3 3/16 in.				
CKVR20	90 mm	192.0	174.8	44.5	55.4
	3 5/8 in.				
	3 1/2 in.				
CKVR22	100 mm	212.1	194.8	52.6	63.5
	4 in.				
	100 mm				
CKVR24	110 mm	212.1	194.8	52.6	63.5
	4 3/16 in.				
	4 1/4 in.				
CKVR26	115 mm	241.3	223.8	56.9	69.6
	4 7/16 in.				
	4 1/2 in.				
CKVR28	125 mm	241.3	223.8	56.9	69.6
	4 15/16 in.				
	5 in.				

UFP AND HSY FLANGE BLOCK BACKING PLATE DIMENSIONS

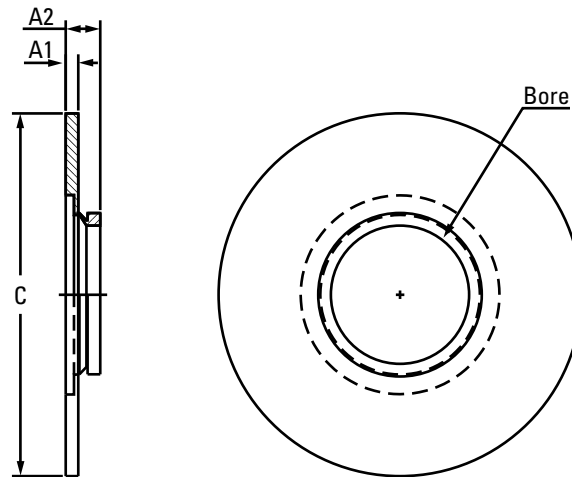

TABLE 48. UFP BACKING PLATE DIMENSIONS⁽¹⁾

Cover Part No.	Shaft Dia.	A1	A2	C
	mm in.	mm in.	mm in.	mm in.
UFP035MM UFP107 UFP108	35mm 1- ⁷ / ₁₆ in. 1- ¹ / ₂ in.	5.1 0.20	12.7 0.50	95.3 3.75
UFP111 UFP040MM UFP112 UFP045MM	1- ¹¹ / ₁₆ in. 40mm 1- ³ / ₄ in. 45mm	5.1 0.20	14.0 0.55	105.9 4.17
UFP115 UFP200 UFP050MM	1- ¹⁵ / ₁₆ in. 2 in. 50mm	3.8 0.15	12.7 0.50	106.4 4.19
UFP203 UFP204 UFP055MM	2- ³ / ₁₆ in. 2- ¹ / ₄ in. 55mm	6.4 0.25	15.2 0.60	114.6 4.51
UFP060MM UFP207 UFP208 UFP065MM	60mm 2- ⁷ / ₁₆ in. 2- ¹ / ₂ in. 65mm	5.1 0.20	14.0 0.55	146.1 5.75
UFP211 UFP070MM UFP212 UPF215 UFP300 UFP075MM	2- ¹¹ / ₁₆ in. 70mm 2- ³ / ₄ in. 2- ¹⁵ / ₁₆ in. 3 in. 75mm	5.1 0.20	16.0 0.63	146.6 5.77
UFP303 UFP304 UFP080MM UFP085MM UFP307 UFP308 UFP090MM	3- ³ / ₁₆ in. 3- ¹ / ₄ in. 80mm 85mm 3- ⁷ / ₁₆ in. 3- ¹ / ₂ in. 90mm	5.1 0.20	16.0 0.63	187.5 7.38
UFP315 UFP400 UFP100MM	3- ¹⁵ / ₁₆ in. 4 in. 100mm	5.1 0.20	16.0 0.63	206.5 8.13
UFP110MM UFP407 UFP408 UFP115MM	110mm 4- ⁷ / ₁₆ in. 4- ¹ / ₂ in. 115mm	5.1 0.20	17.8 0.70	215.9 8.50
UFP125MM UFP415 UFP500 UFP130MM	125mm 4- ¹⁵ / ₁₆ in. 5 in. 130mm	5.1 0.20	17.8 0.70	299 11.77

⁽¹⁾Actual backing plate may differ from drawing.

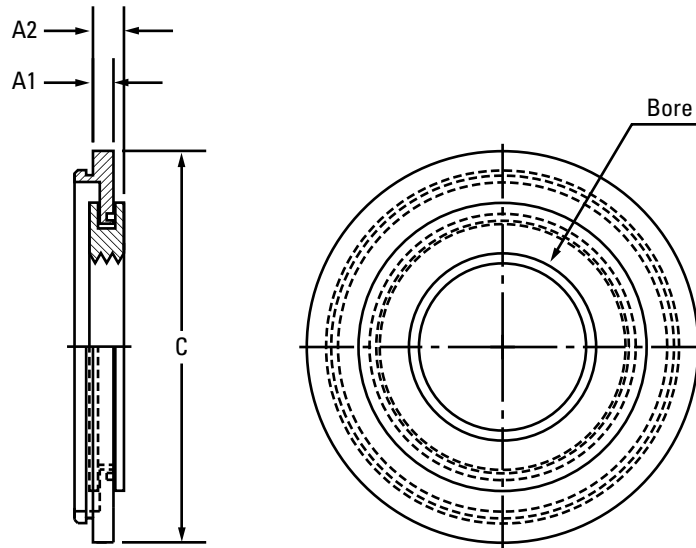

TABLE 49. HSY BACKING PLATE DIMENSIONS

Cover Part No.	Shaft Dia.	A1	A2	C
	mm in.	mm in.	mm in.	mm in.
HSY035MM	35mm	5.1	7.6	85.9
HSY107	1- ⁷ / ₁₆ in.	0.20	0.30	3.38
HSY108	1- ¹ / ₂ in.			
HSY111	1- ¹¹ / ₁₆ in.			
HSY040MM	40mm	8.9	11.4	101.6
HSY112	1- ³ / ₄ in.	0.35	0.45	4.00
HSY045MM	45mm			
HSY115	1- ¹⁵ / ₁₆ in.	5.1	7.6	108.0
HSY200	2 in.	0.20	0.30	4.25
HSY050MM	50mm			
HSY203	2- ³ / ₁₆ in.	5.1	7.6	120.1
HSY204	2- ¹ / ₄ in.	0.20	0.30	4.73
HSY055MM	55mm			
HSY060MM	60mm			
HSY207	2- ⁷ / ₁₆ in.	6.4	8.9	133.4
HSY208	2- ¹ / ₂ in.	0.25	0.35	5.25
HSY065MM	65mm			
HSY211	2- ¹¹ / ₁₆ in.			
HSY070MM	70mm			
HSY212	2- ³ / ₄ in.	6.4	8.9	155.7
UPF215	2- ¹⁵ / ₁₆ in.	0.25	0.35	6.13
HSY300	3 in.			
HSY075MM	75mm			
HSY303	3- ³ / ₁₆ in.			
HSY304	3- ¹ / ₄ in.			
HSY080MM	80mm	5.1	7.6	181.1
HSY085MM	85mm	0.20	0.30	7.13
HSY307	3- ⁷ / ₁₆ in.			
HSY308	3- ¹ / ₂ in.			
HSY090MM	90mm			
HSY315	3- ¹⁵ / ₁₆ in.	5.1	7.6	199.9
HSY400	4 in.	0.20	0.30	7.87
HSY100MM	100mm			
HSY110MM	110mm			
HSY407	4- ⁷ / ₁₆ in.	7.6	10.2	245.0
HSY408	4- ¹ / ₂ in.	0.30	0.40	10.00
HSY115MM	115mm			

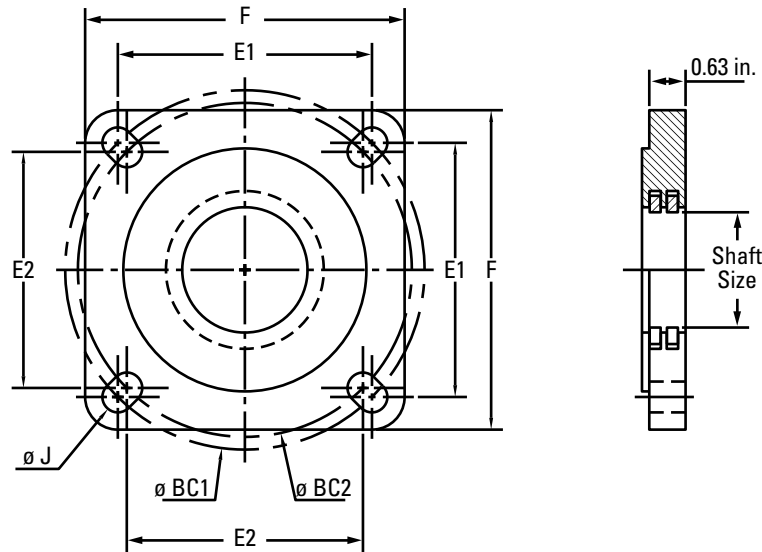

TABLE 50. STEEL BACKING PLATES AVAILABLE IN ECCENTRIC AND SET SCREW LOCKING HOUSING STYLES QMF/QAF AND QMFL/QAFL

Part Number	Shaft Dia.	F	E1	E2	BC1	BC2	J	Bolt Size	Weight
	mm in.	mm in.	mm in.	mm in.	mm in.	mm in.	mm [+1.5/-0] in. [+0.063/-0]	mm in.	kg lb.
BP10T115S	1 1/16 in.	139.7 5.50	111.1 4.375	103.3 4.066	157.1 6.187	146.1 5.750	13.5 0.531	12 1/2	2.0 4.5
BP10T200S	2 in.								
BP10T050S	50 mm								
BP11T203S	2 3/16 in.	157.2 6.19	123.8 4.875	114.5 4.508	175.1 6.894	161.9 6.375	16.7 0.656	16 5/8	2.8 6.1
BP11T204S	2 1/4 in.								
BP11T055S	55 mm								
BP13T060S	60 mm	168.4 6.63	136.5 5.375	121.2 4.773	193.1 7.601	171.5 6.750	16.7 0.656	16 5/8	3.0 6.7
BP13T207S	2 7/16 in.								
BP13T208S	2 1/2 in.								
BP13T065S	65 mm	189.0 7.44	152.4 6.000	141.4 5.568	215.5 8.485	200.0 7.875	21.0 0.827	20 3/4	3.9 8.6
BP15T211S	2 1/16 in.								
BP15T212S	2 3/4 in.								
BP15T070S	70 mm	219.2 8.63	178.0 7.007	170.6 6.718	251.7 9.910	241.3 9.500	21.0 0.827	20 3/4	5.4 12.0
BP15T215S	2 1/8 in.								
BP15T300S	3 in.								
BP15T075S	75 mm	253.2 9.97	196.9 7.750	193.1 7.601	278.4 10.960	273.1 10.750	25.0 0.984	24 1	7.1 15.6
BP18T303S	3 3/16 in.								
BP18T304S	3 1/4 in.								
BP18T080S	80 mm	276.4 10.88	222.3 8.750	N/A	314.3 12.375	N/A	25.0 0.984	24 1	8.4 18.5
BP18T085S	85 mm								
BP18T307S	3 7/16 in.								
BP18T308S	3 1/2 in.								
BP18T090S	90 mm								
BP20T311S	3 1/16 in.								
BP20T312S	3 3/4 in.								
BP20T315S	3 15/16 in.								
BP20T400S	4 in.								
BP20T100S	100 mm								
Bore Size 110mm – 115mm only available in QMF/QAF Series Housings									
BP22T110S	110 mm								
BP22T407S	4 7/16 in.								
BP22T408S	4 1/2 in.								
BP22T115S	115 mm								

V-LOCK® SERIES

The V-Lock® locking mechanism (U.S. Pat. No. 7344313) evenly distributes force on the shaft, helping eliminate fretting corrosion. V-Lock provides maximum holding power and prevents overtightening.

In response to customer input, V-Lock was specifically designed to address common spherical roller bearing solid-block housed unit problems:

- Reliable mechanical withdrawal.
- Preset spherical inner ring radial internal clearances (feeler gages are not required).
- Quick installation (typically 10 minutes or less).
- Highest shaft-holding power.
- Works well in high-speed applications where shaft centering is an issue.



Fig. 42. V-Lock® series insert.

YOU HAVE CHOICES

For the V-Lock series, you can select either single-nut or double-nut versions and choose from many seal configurations and housing styles, which are shown on page 65.

HOUSINGS

- Two-bolt pillow blocks.
- Four-bolt pillow blocks.
- Flange blocks.
- Piloted flange cartridges.
- Cartridge blocks.
- Take-up blocks.

SEALS

- Labyrinth: DuPont Teflon (T).
- Triple-lip: nitrile rubber (M), urethane (O) and DuPont Viton (N).
- Double-lip: nitrile rubber (B) and DuPont Viton (C).
- Steel and urethane closed-end covers (CS).
- Steel and urethane open-end covers (CV) with:
 - DuPont Teflon (T).
 - Triple-lip seal (DR).
 - V-ring seal (VR).

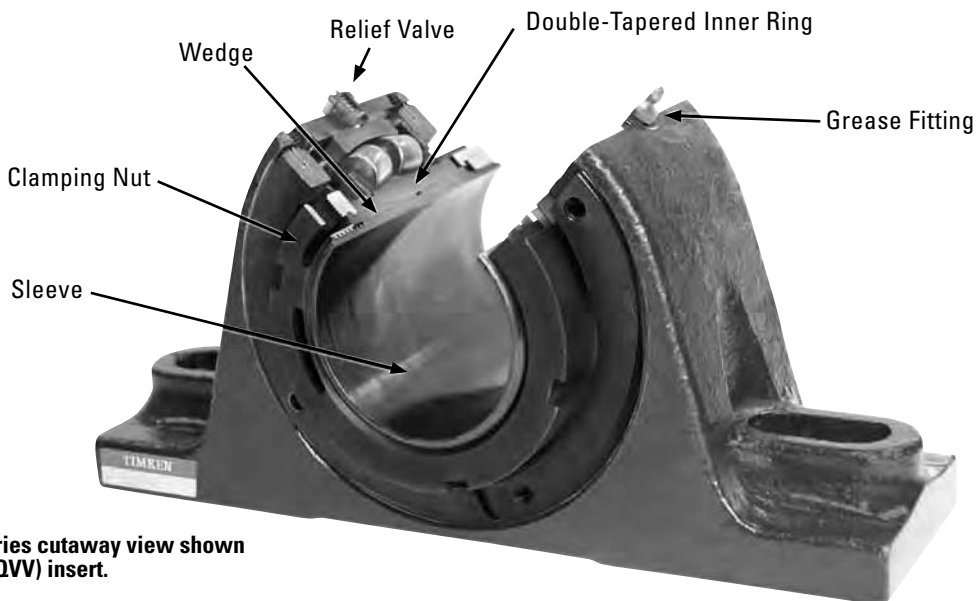
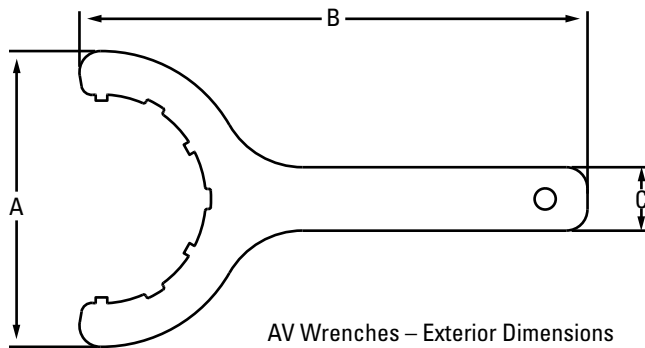

Fig. 43. V-Lock series cutaway view shown with double-nut (QVV) insert.



V-LOCK SERIES WRENCH

New V-Lock series wrenches make installation easy; the wrenches are specifically designed for the V-Lock adapter sleeves, providing three or four points of contact and maximum wrench engagement versus traditional spanner wrench designs. Made from tough high alloy steel for long service life. Eight wrenches are all you need for the 36 different bore sizes.

Fig. 44. V-Lock® series wrench.



TABLE 51. V-LOCK SERIES WRENCH DIMENSIONS

Part #	Shaft Dia.	A	B	C
	mm in.	in.	in.	in.
AVWR11	1 1/16 in. 2 in. 50 mm	5.03	10.78	1.50
AVWR12-13	2 3/16 in. 2 1/4 in. 55 mm	5.19	10.89	1.50
AVWR14-15	60 mm 2 7/16 in. 2 1/2 in. 65 mm	5.74	11.25	1.50
AVWR16-17	2 11/16 in. 2 3/4 in. 70 mm 2 15/16 in. 3 in. 75 mm	6.30	11.61	1.50
AVWR19-20	3 3/16 in. 3 1/4 in. 80 mm 85 mm 3 7/16 in. 3 1/2 in. 90 mm	7.00	12.02	1.50
AVWR22	3 11/16 in. 3 3/4 in. 100 mm 3 15/16 in. 4 in.	7.54	12.67	1.50
AVWR26	110 mm 4 7/16 in. 4 1/2 in. 115 mm	8.92	13.30	1.50
AVWR28	125 mm 4 15/16 in. 5 in. 130 mm	9.52	13.65	1.50

V-LOCK SERIES (ADAPTER LOCK) U.S. PAT. NO. 7344313

	Housing Type	Primary Seals						Secondary Seals and Covers					
		M	N	O	B	C	T	Open-End Cover			Closed-End Cover	HSY Flange Cartridge Backing Plate	UFP Backing Plate
								DR	VR	T		DR	
V-Lock® (Timken Exclusive Double Taper Lock)	Pillow Block	•	•	•	•	•	•	•	•	•	•		
	Flange Block	•	•	•	•	•	•	•	•	•	•		
	Piloted Flange Cartridge	•	•	•	•	•	•	•	•	•	•		
	Take-Up Block	•	•	•	•	•	•	•	•	•	•		
	Cartridge Block	•	•	•	•	•	•	•	•	•	•		
CL Series (Set Screw Lock)	Pillow Block	•	•	•	•	•	•	•	•	•	•		
	Flange Block	•	•	•	•	•	•	•	•	•	•		•
	Piloted Flange Cartridge	•	•	•	•	•	•	•	•	•	•	•	
	Take-Up Block	•	•	•	•	•	•	•	•	•	•		
	Cartridge Block	•	•	•	•	•	•	•	•	•	•		
	Hanger Block	•	•	•	•	•	•	•	•	•	•		
EC Series (Eccentric Lock)	Pillow Block	•	•	•	•	•	•	•	•	•	•		
	Flange Block	•	•	•	•	•	•	•	•	•	•		•
	Piloted Flange Cartridge	•	•	•	•	•	•	•	•	•	•	•	
	Take-Up Block	•	•	•	•	•	•	•	•	•	•		
	Cartridge Block	•	•	•	•	•	•	•	•	•	•		
	Hanger Block	•	•	•	•	•	•	•	•	•	•		
TA Series (Tapered Adapter Lock)	Pillow Block	•	•	•	•	•	•	•	•	•	•		
	Flange Block	•	•	•	•	•	•	•	•	•	•		
	Piloted Flange Cartridge	•	•	•	•	•	•	•	•	•	•		
	Cartridge Block	•	•	•	•	•	•	•	•	•	•		
DV Series (Tapered Adapter Lock)	Pillow Block	•	•	•	•	•	•	•	•	•	•		
	Flange Block	•	•	•	•	•	•	•	•	•	•		
	Piloted Flange Cartridge	•	•	•	•	•	•	•	•	•	•		

QVVP TWO-BOLT PILLOW BLOCKS – STRAIGHT BORE EQUIVALENT

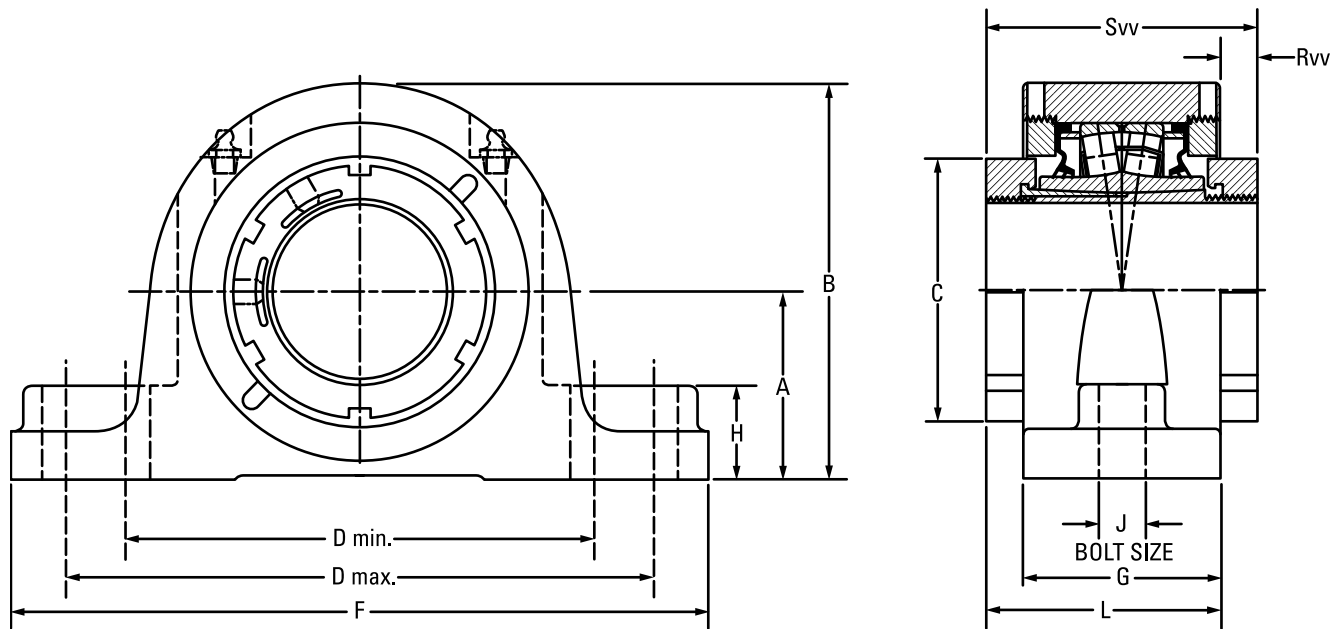

Bearing Part No. ⁽¹⁾	Shaft Dia.	Bearing No.	A	B	C	D min.	D max.	F	G	H	J	L	Rvv	Svv	Wt.	
	mm in.		mm in.	mm in.	mm in.	mm in.	mm in.	mm in.	mm in.	mm in.	mm in.	mm in.	mm in.	mm in.	kg lbs.	
QVVP11V115S	1 15/16 in.	22211	57.2	122.2	75.9	152.4	181.1	225.6	62.0	31.8	16	82.0	20.1	102.1	6.4	
QVVP11V200S	2 in.		2.25	4.81	2.99	6.00	7.13	8.88	2.44	1.25	5/8	3.23	0.79	4.02	14	
QVVP11V050S	50 mm															
QVVP12V203S	2 3/16 in.	22212	63.5	133.4	80.3	165.1	200.2	244.6	66.8	31.8	16	84.6	17.8	102.1	7.7	
QVVP12V204S	2 1/4 in.		2.50	5.25	3.16	6.50	7.88	9.63	2.63	1.25	5/8	3.33	0.70	4.02	17	
QVVP12V055S	55 mm															
QVVP14V060S	60 mm	22214	69.9	147.3	94.0	174.8	219.2	260.4	73.7	35.1	16	88.9	15.2	103.9	10.0	
QVVP14V207S	2 7/16 in.		2.75	5.80	3.70	6.88	8.63	10.25	2.90	1.38	5/8	3.50	0.60	4.09	22	
QVVP14V208S	2 1/2 in.															
QVVP14V065S	65 mm															
QVVP16V211S	2 11/16 in.	22216	79.5	164.3	106.4	200.2	244.6	295.4	76.2	35.1	20	91.2	15.0	106.2	12.7	
QVVP16V212S	2 3/4 in.		3.13	6.47	4.19	7.88	9.63	11.63	3.00	1.38	3/4	3.59	0.59	4.18	28	
QVVP16V070S	70 mm															
QVVP16V215S	2 15/16 in.															
QVVP16V300S	3 in.	22219	95.3	195.3	124.5	238.3	285.8	342.9	86.6	47.8	24	102.1	15.5	117.6	20.4	
QVVP16V075S	75 mm		3.75	7.69	4.90	9.38	11.25	13.50	3.41	1.88	7/8	4.02	0.61	4.63	45	
QVVP19V303S	3 3/16 in.															
QVVP19V304S	3 1/4 in.															
QVVP19V080S	80 mm															
QVVP19V085S	85 mm															
QVVP19V307S	3 7/16 in.	22222	104.9	219.7	139.7	255.0	320.0	362.0	102.6	50.8	24	116.6	14.0	130.3	26.8	
QVVP19V308S	3 1/2 in.		4.13	8.65	5.50	10.04	12.60	14.25	4.04	2.00	1	4.59	0.55	5.13	59	
QVVP19V090S	90 mm															
QVVP22V311S	3 11/16 in.															
QVVP22V312S	3 3/4 in.															
QVVP22V100S	100 mm															
QVVP22V315S	3 15/16 in.															
QVVP22V400S	4 in.															

⁽¹⁾Double-nut (QVV) part number shown. Single-nut (QV) version available upon request.

QVVPL TWO-BOLT PILLOW BLOCKS – STRAIGHT BORE EQUIVALENT

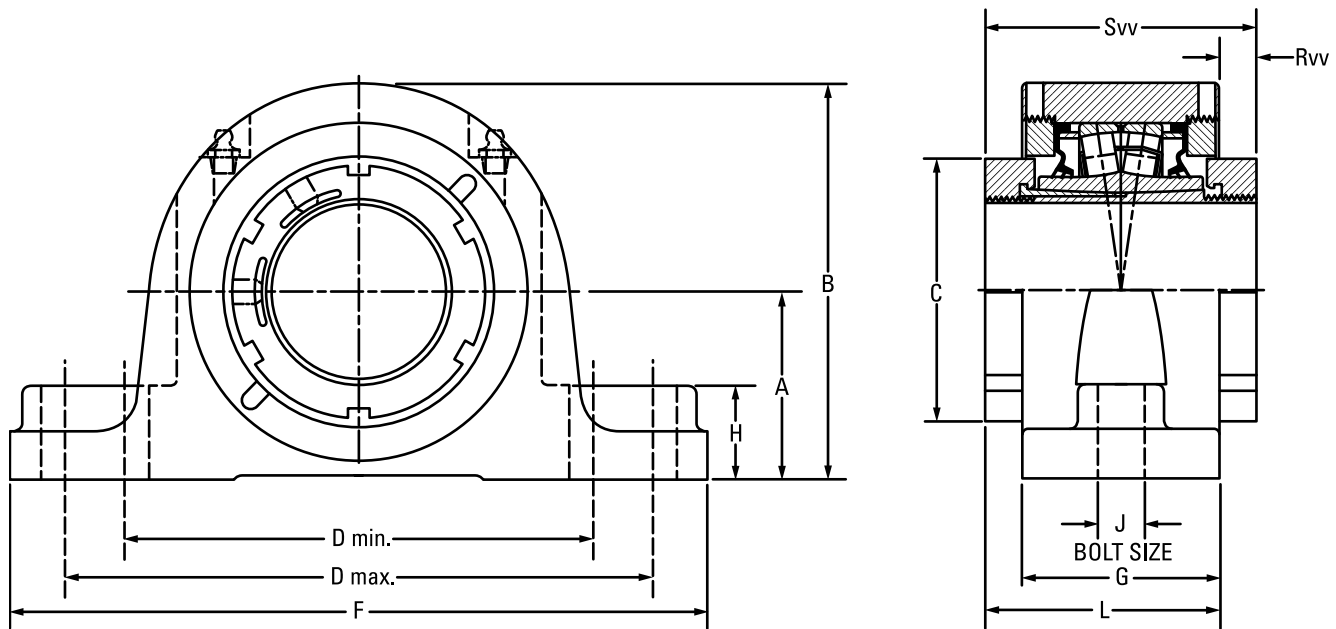

Bearing Part No. ⁽¹⁾	Shaft Dia.	Bearing No.	A	B	C	D min.	D max.	F	G	H	J	L	Rvv	Svv	Wt.
	mm in.		mm in.	mm in.	mm in.	mm in.	mm in.	mm in.	mm in.	mm in.	mm in.	mm in.	mm in.	mm in.	kg lbs.
QVVPL11V115S	1 15/16 in.	22211	57.2	122.2	75.9	150.6	161.5	212.9	62.0	31.8	16	82.0	20.1	102.1	6.4
QVVPL11V200S	2 in.		2.25	4.81	2.99	5.93	6.36	8.38	2.44	1.25	5/8	3.23	0.79	4.02	14
QVVPL11V050S	50 mm														
QVVPL12V203S	2 3/16 in.	22212	63.5	133.4	80.3	165.1	179.3	225.6	65.5	31.8	16	83.8	18.3	102.1	7.7
QVVPL12V204S	2 1/4 in.		2.50	5.25	3.16	6.50	7.06	8.88	2.58	1.25	5/8	3.30	0.72	4.02	17
QVVPL12V055S	55 mm														
QVVPL14V060S	60 mm	22214	69.9	147.3	94.0	173	189.0	235.0	73.7	35.1	16	88.9	15.2	103.9	10.0
QVVPL14V207S	2 7/16 in.		2.75	5.80	3.70	6.81	7.44	9.25	2.90	1.38	5/8	3.50	0.60	4.09	22
QVVPL14V208S	2 1/2 in.														
QVVPL14V065S	65 mm	22216	82.6	167.4	106.4	195.6	213.4	265.2	76.2	35.1	20	91.2	15.0	106.2	12.7
QVVPL16V211S	2 11/16 in.		3.25	6.59	4.19	7.70	8.40	10.44	3.00	1.38	3/4	3.59	0.59	4.18	28
QVVPL16V212S	2 3/4 in.														
QVVPL16V070S	70 mm	22219	95.3	195.3	124.5	235.0	273.1	330.2	86.6	47.8	24	102.1	15.5	117.6	20.4
QVVPL16V215S	2 15/16 in.		3.75	7.69	4.90	9.25	10.75	13.00	3.41	1.88	7/8	4.02	0.61	4.63	45
QVVPL16V300S	3 in.														
QVVPL16V075S	75 mm	22222	108	223	139.7	255.0	320.0	362.0	102.6	53.8	24	116.6	14.0	130.3	26.8
QVVPL19V303S	3 3/16 in.		4.25	8.78	5.50	10.04	12.60	14.25	4.04	2.12	1	4.59	0.55	5.13	59
QVVPL19V304S	3 1/4 in.														
QVVPL19V080S	80 mm	22219	95.3	195.3	124.5	235.0	273.1	330.2	86.6	47.8	24	102.1	15.5	117.6	20.4
QVVPL19V085S	85 mm		3.75	7.69	4.90	9.25	10.75	13.00	3.41	1.88	7/8	4.02	0.61	4.63	45
QVVPL19V307S	3 7/16 in.														
QVVPL19V308S	3 1/2 in.	22222	108	223	139.7	255.0	320.0	362.0	102.6	53.8	24	116.6	14.0	130.3	26.8
QVVPL19V090S	90 mm		4.25	8.78	5.50	10.04	12.60	14.25	4.04	2.12	1	4.59	0.55	5.13	59
QVVPL22V311S	3 11/16 in.														
QVVPL22V312S	3 3/4 in.	22222	108	223	139.7	255.0	320.0	362.0	102.6	53.8	24	116.6	14.0	130.3	26.8
QVVPL22V100S	100 mm		4.25	8.78	5.50	10.04	12.60	14.25	4.04	2.12	1	4.59	0.55	5.13	59
QVVPL22V315S	3 15/16 in.														
QVVPL22V400S	4 in.														

⁽¹⁾Double-nut (QVV) part number shown. Single-nut (QV) version available upon request.

QVVP SAFTWO-BOLT PILLOW BLOCKS – TAPERED BORE EQUIVALENT

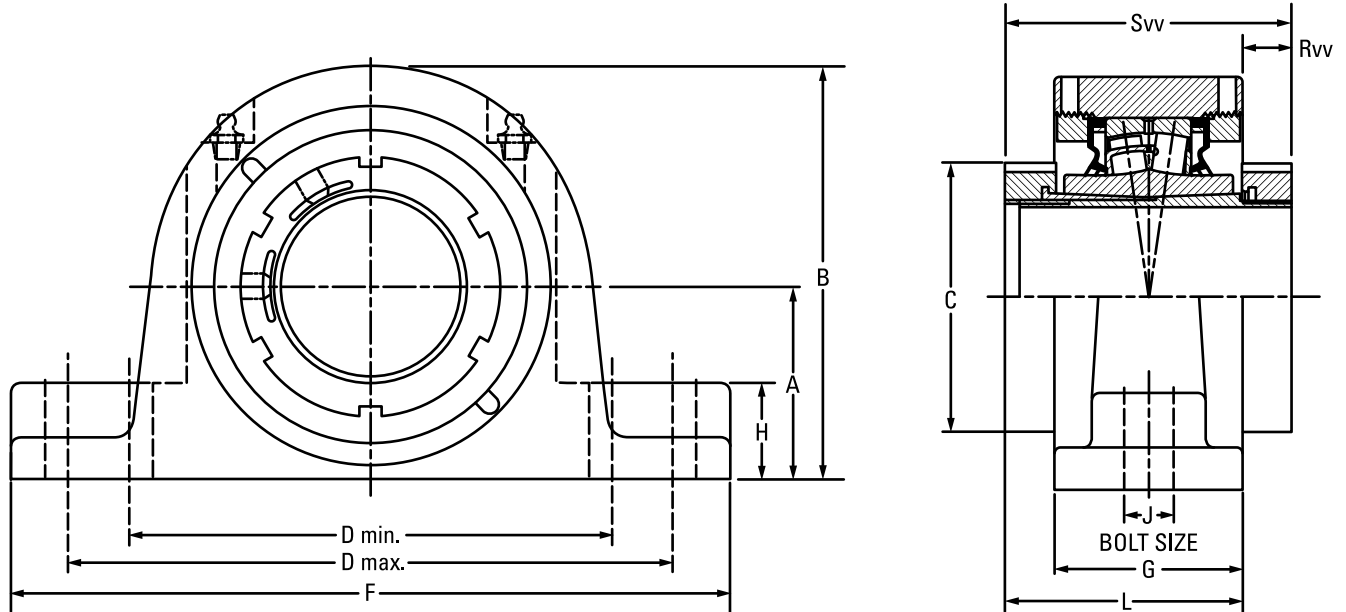

Bearing Part No. ⁽¹⁾	Shaft Dia.	Bearing No.	A	B	C	D min.	D max.	F	G	H	J	L	Rvv	Svv	Wt.
			mm in.	mm in.	mm in.	mm in.	mm in.	mm in.	mm in.	mm in.	mm in.	mm in.	mm in.	mm in.	mm in.
QVVP13V203S	2 3/16 in.	22213	76.2	151.1	80.3	182.9	233.7	261.9	68.6	31.2	16	85.3	16.8	102.1	10.4
QVVP13V204S	2 1/4 in.		3.00	5.95	3.16	7.20	9.20	10.31	2.70	1.23	5/8	3.36	0.66	4.02	23
QVVP13V055S	55 mm														
QVVP15V060S	60 mm	22215	82.6	163.3	94.0	200.2	244.6	276.4	68.6	31.8	16	86.4	17.8	103.9	12.2
QVVP15V207S	2 7/16 in.		3.25	6.43	3.70	7.88	9.63	10.88	2.70	1.25	5/8	3.40	0.70	4.09	27
QVVP15V208S	2 1/2 in.														
QVVP15V065S	65 mm	22217	95.3	186	106.4	241.3	279.4	320.8	76.2	33.8	20	91.2	15.0	106.2	15.0
QVVP17V211S	2 11/16 in.		3.75	7.32	4.19	9.50	11.00	12.63	3.00	1.33	3/4	3.59	0.59	4.18	33
QVVP17V212S	2 3/4 in.														
QVVP17V070S	70 mm	22220	114.3	219.2	124.5	276.4	327.2	368.3	86.9	41.4	24	102.4	15.5	117.6	29.5
QVVP17V215S	2 15/16 in.		4.50	8.63	4.90	10.88	12.88	14.50	3.42	1.63	7/8	4.03	0.61	4.63	65
QVVP17V300S	3 in.														
QVVP17V075S	75 mm	22222	125.5	240.5	139.7	317.5	368.3	406.4	100.6	50.8	24	115.6	15.0	130.3	38.1
QVVP20V303S	3 3/16 in.		4.94	9.47	5.50	12.50	14.50	16.00	3.96	2.00	7/8	4.55	0.59	5.13	84
QVVP20V304S	3 1/4 in.														
QVVP20V080S	80 mm	22226	152.4	284.0	174.8	362.0	400.1	444.5	128	51.8	24	153.2	36.5	178.3	61.7
QVVP20V085S	85 mm		6.00	11.18	6.88	14.25	15.75	17.50	5.04	2.04	1	6.03	1.44	7.02	136
QVVP20V307S	3 7/16 in.														
QVVP20V308S	3 1/2 in.	22228	152.4	290.8	190.0	384.3	447.8	499.9	85.6	51.8	30	132.0	46.5	178.3	61.8
QVVP20V090S	90 mm		6.00	11.45	7.48	15.13	17.63	19.68	3.37	2.04	1 1/4	5.20	1.83	7.02	136
QVVP22V311S	3 11/16 in.														
QVVP22V312S	3 3/4 in.	22226	152.4	284.0	174.8	362.0	400.1	444.5	128	51.8	24	153.2	36.5	178.3	61.7
QVVP22V100S	100 mm		6.00	11.18	6.88	14.25	15.75	17.50	5.04	2.04	1	6.03	1.44	7.02	136
QVVP22V315S	3 15/16 in.														
QVVP22V400S	4 in.	22228	152.4	290.8	190.0	384.3	447.8	499.9	85.6	51.8	30	132.0	46.5	178.3	61.8
QVVP26V110S	110 mm		6.00	11.45	7.48	15.13	17.63	19.68	3.37	2.04	1 1/4	5.20	1.83	7.02	136
QVVP26V407S	4 7/16 in.														
QVVP26V408S	4 1/2 in.	22228	152.4	290.8	190.0	384.3	447.8	499.9	85.6	51.8	30	132.0	46.5	178.3	61.8
QVVP26V115S	115 mm		6.00	11.45	7.48	15.13	17.63	19.68	3.37	2.04	1 1/4	5.20	1.83	7.02	136
QVVP28V125S	125 mm														
QVVP28V415S	4 15/16 in.	22228	152.4	290.8	190.0	384.3	447.8	499.9	85.6	51.8	30	132.0	46.5	178.3	61.8
QVVP28V500S	5 in.		6.00	11.45	7.48	15.13	17.63	19.68	3.37	2.04	1 1/4	5.20	1.83	7.02	136
QVVP28V130S	130 mm														

⁽¹⁾Double-nut (QVV) part number shown. Single-nut (QV) version available upon request.

QVVPN SN-STYLE TWO-BOLT PILLOW BLOCKS – TAPERED BORE EQUIVALENT

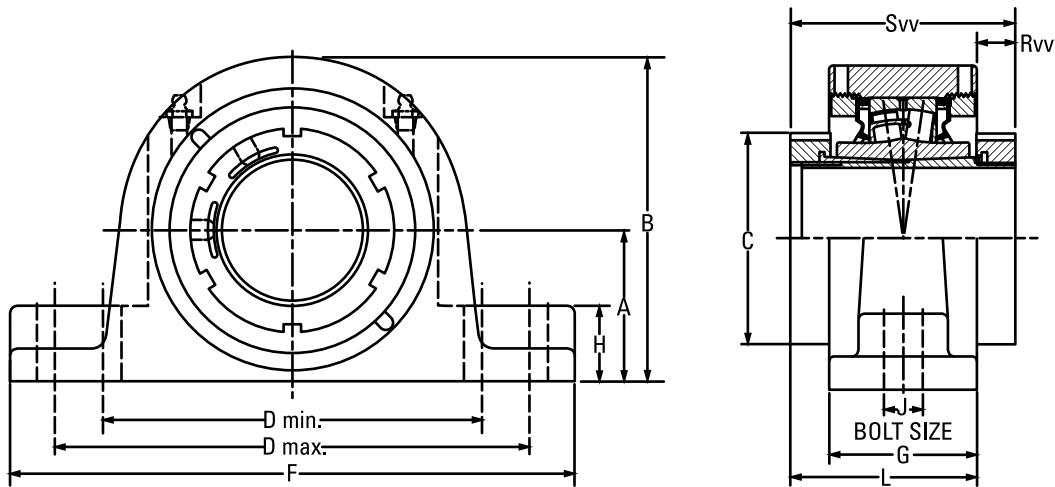

Bearing Part No. ⁽¹⁾	Shaft Dia.	Bearing No.	A	B	C	D min.	D max.	F	G	H	J	L	Rvv	Svv	Wt.	
			mm in.	mm in.	mm in.	mm in.	mm in.	mm in.	mm in.	mm in.	mm in.	mm in.	mm in.	mm in.	mm in.	kg lbs.
QVVPN11V115S	1 15/16 in.	22211	69.9	135.4	75.9	165.1	221.0	251.0	60.5	31.8	16	81.3	20.8	102.1	7.7	
QVVPN11V200S	2 in.		2.750	5.33	2.99	6.50	8.70	9.88	2.38	1.25	5/8	3.20	0.82	4.02	17	
QVVPN11V050S	50 mm															
QVVPN12V055S	55 mm	22212	70.0	140.5	80.0	177.8	219.2	254.0	60.5	31.8	16	81.3	20.8	102.1	9.1	
			2.756	5.53	3.15	7.00	8.63	10.00	2.38	1.25	5/8	3.20	0.82	4.02	20	
QVVPN13V203S	2 3/4 in.	22213	80.0	154.9	80.3	182.9	233.7	261.9	68.6	35.1	16	85.3	16.8	102.1	10.4	
QVVPN13V204S	2 1/4 in.		3.150	6.10	3.16	7.20	9.20	10.31	2.70	1.38	5/8	3.36	0.66	4.02	23	
QVVPN14V060S	60 mm	22214	80.0	157.0	94.0	196.0	235.0	275.0	74.0	35.1	16	89.0	15.0	104.0	10.4	
			3.150	6.18	3.70	7.72	9.25	10.83	2.91	1.38	5/8	3.50	0.59	4.09	23	
QVVPN15V207S	2 7/16 in.	22215	80.0	160.8	94.0	200.2	244.6	276.4	68.6	29.2	16	86.4	17.8	103.9	12.2	
QVVPN15V208S	2 1/2 in.		3.150	6.33	3.70	7.88	9.63	10.88	2.70	1.15	5/8	3.40	0.70	4.09	27	
QVVPN15V065S	65 mm															
QVVPN16V211S	2 11/16 in.	22216	95.0	180.3	106.0	235.0	266.7	315.0	72.6	31.8	20	89.4	16.8	106.0	13.6	
QVVPN16V212S	2 3/4 in.		3.740	7.10	4.17	9.25	10.50	12.40	2.86	1.25	3/4	3.52	0.66	4.17	30	
QVVPN16V070S	70 mm															
QVVPN17V215S	2 15/16 in.	22217	95.3	185.9	106.4	241.3	279.4	345.0	76.2	33.8	20	91.2	15.0	106.2	15.0	
QVVPN17V300S	3 in.		3.750	7.32	4.19	9.50	11.00	13.58	3.00	1.33	3/4	3.59	0.59	4.18	33	
QVVPN17V075S	75 mm															
QVVPN19V303S	3 3/16 in.	22219	100.0	200.0	124.0	279.0	292.0	345.0	86.0	38.9	20	102.0	16.0	118.1	22.2	
QVVPN19V304S	3 1/4 in.		3.937	7.87	4.88	10.98	11.50	13.58	3.39	1.53	3/4	4.02	0.63	4.65	49	
QVVPN19V080S	80 mm															
QVVPN19V085S	85 mm	22219	112.0	212.3	124.0	285.8	295.4	346.2	82.8	38.9	20	100.6	17.8	118.1	23.1	
			4.409	8.36	4.88	11.25	11.63	13.63	3.26	1.53	3/4	3.96	0.70	4.65	51	
QVVPN20V307S	3 7/16 in.	22220	112.0	216.9	124.5	276.4	327.2	368.3	86.9	38.9	24	102.4	15.5	117.6	29.5	
QVVPN20V308S	3 1/2 in.		4.409	8.54	4.90	10.88	12.88	14.50	3.42	1.53	7/8	4.03	0.61	4.63	65	
QVVPN20V090S	90 mm															
QVVPN22V311S	3 11/16 in.	22222	125.0	240.5	139.7	317.5	368.3	406.4	100.6	50.8	24	115.6	15.0	130.3	38.1	
QVVPN22V312S	3 3/4 in.		4.921	9.47	5.50	12.50	14.50	16.00	3.96	2.00	7/8	4.55	0.59	5.13	84	
QVVPN22V100S	100 mm															
QVVPN22V315S	3 15/16 in.															
QVVPN22V400S	4 in.															
QVVPN24V110S	110 mm	22224	140.0	262.9	174.8	344.4	355.6	409.7	97.8	50.8	24	138.2	40.4	178.3	49.9	
			5.512	10.35	6.88	13.56	14.00	16.13	3.85	2.00	7/8	5.44	1.59	7.02	110	
QVVPN26V407S	4 7/16 in.	22226	150.0	281.7	174.8	367.3	400.1	444.5	128.0	49.3	24	153.2	25.1	178.3	61.7	
QVVPN26V408S	4 1/2 in.		5.906	11.09	6.88	14.46	15.75	17.50	5.04	1.94	1	6.03	0.99	7.02	136	
QVVPN26V115S	115 mm															
QVVPN28V125S	125 mm	22228	150.0	288.5	190.0	384.3	447.8	499.9	85.6	49.3	30	132.0	46.5	178.3	63.0	
QVVPN28V415S	4 15/16 in.		5.906	11.36	7.48	15.13	17.63	19.68	3.37	1.94	1 1/4	5.20	1.83	7.02	138	
QVVPN28V500S	5 in.															
QVVPN28V130S	130 mm															

⁽¹⁾Double-nut (QVV) part number shown. Single-nut (QV) version available upon request.

QVVSN SN-STYLE TWO-BOLT PILLOW BLOCKS – PURE METRIC DESIGN

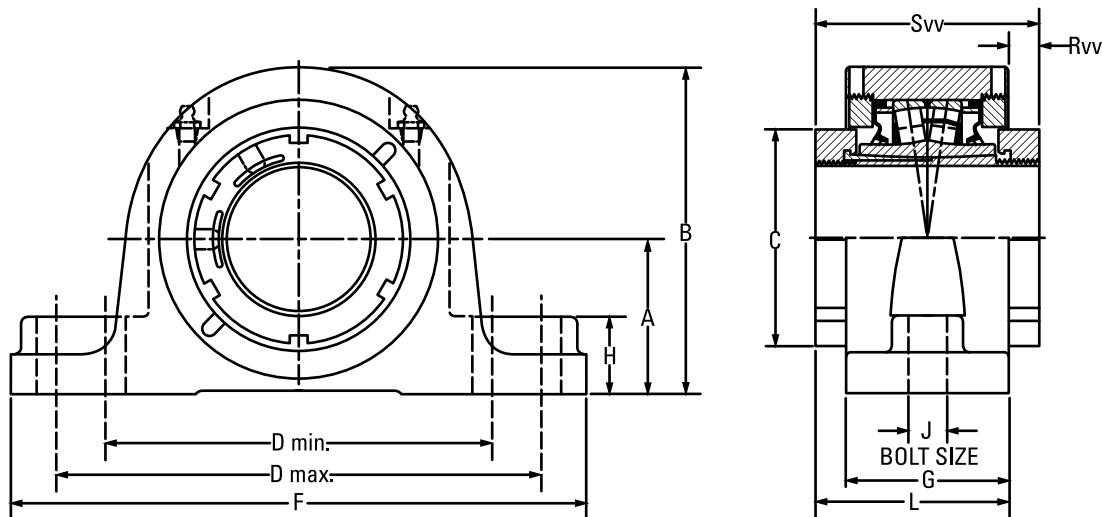

Bearing Part No. ⁽¹⁾	Shaft Dia.	Bearing No.	A	B	C	D min.	D max.	F	G	H	J	L	Rvv	Svv	Wt.
	mm in.		mm in.	mm in.	mm in.	mm in.	mm in.	mm in.	mm in.	mm in.	mm in.	mm in.	mm in.	mm in.	kg lbs.
QVVSN11V115S	1 15/16 in.	22211	70 2.76	136 5.35	76 2.99	183 7.20	216 8.50	254 10.00	68 2.68	25 1.00	16 5/8	85 3.35	17 0.67	102 4.02	8.4 18
QVVSN11V200S	2 in.														
QVVSN11V050S	50 mm														
QVVSN12V203S	2 3/16 in.	22212	70 2.76	141 5.55	80 3.15	183 7.20	216 8.50	254 10.00	68 2.68	25 1.00	16 5/8	85 3.35	17 0.67	102 4.02	13.2 29
QVVSN12V204S	2 1/4 in.														
QVVSN12V055S	55 mm														
QVVSN14V060S	60 mm	22214	80 3.15	157 6.18	94 3.70	196 7.72	235 9.25	275 10.83	74 2.91	35 1.38	16 5/8	89 3.50	15 0.59	104 4.09	16.8 37
QVVSN14V207S	2 7/16 in.														
QVVSN14V208S	2 1/2 in.														
QVVSN14V065S	65 mm	22216	95 3.74	183 7.2	106 4.17	241 9.49	279 10.98	316 12.44	76 2.99	34 1.33	20 3/4	91 3.58	15 0.59	106 4.17	20.9 46
QVVSN16V211S	2 11/16 in.														
QVVSN16V212S	2 3/4 in.														
QVVSN16V070S	70 mm	22219	100 3.94	200 7.87	124 4.88	279 10.98	292 11.50	345 13.58	86 3.39	39 1.53	20 3/4	102 4.02	16 0.63	118 4.65	25.4 56
QVVSN16V215S	2 15/16 in.														
QVVSN16V300S	3 in.														
QVVSN16V075S	75 mm	22219	112 4.41	212 8.34	124 4.88	279 10.98	292 11.50	345 13.58	86 3.39	39 1.53	20 3/4	102 4.02	16 0.63	118 4.65	25.4 56
QVVSN19V303S	3 3/16 in.														
QVVSN19V304S	3 1/4 in.														
QVVSN19V080S	80 mm	22219	112 4.41	212 8.34	124 4.88	290 11.42	327 12.87	380 14.96	86 3.39	39 1.53	24 7/8	102 4.02	16 0.63	118 4.65	25.4 56
QVVSN19V085S	85 mm														
QVVSN19V307S	3 7/16 in.														
QVVSN22V311S	3 11/16 in.	22222	125 4.92	241 9.49	140 5.51	319 12.56	366 14.41	410 16.14	101 3.98	50 2.00	24 7/8	116 4.57	15 0.59	130 5.12	35.8 79
QVVSN22V312S	3 3/4 in.														
QVVSN22V100S	100 mm														
QVVSN22V315S	3 15/16 in.	22226	140 5.51	270 10.63	175 6.89	332 13.07	365 14.37	410 16.14	113 4.45	39 1.53	24 7/8	146 5.75	33 1.30	178 7.01	39.9 88
QVVSN22V400S	4 in.														
QVVSN26V110S	110 mm														
QVVSN26V407S	4 7/16 in.	22226	150 5.91	280 11.02	175 6.89	367 14.45	400 15.75	445 17.52	113 4.45	49 1.92	24 7/8	146 5.75	33 1.30	178 7.01	39.9 88
QVVSN26V408S	4 1/2 in.														
QVVSN26V115S	115 mm														
QVVSN28V125S	125 mm	22228	150 5.91	290 11.41	190 7.48	402 15.83	435 17.13	500 19.68	117 4.61	49 1.92	30 1 1/4	148 5.83	31 1.22	178 7.01	67.0 147
QVVSN28V415S	4 15/16 in.														
QVVSN28V500S	5 in.														
QVVSN28V130S	130 mm														

⁽¹⁾Double-nut (QVV) part number shown. Single-nut (QV) version available upon request.

QVVPKT 9000 SERIES TWO-BOLT PILLOW BLOCKS – TAPERED BORE EQUIVALENT

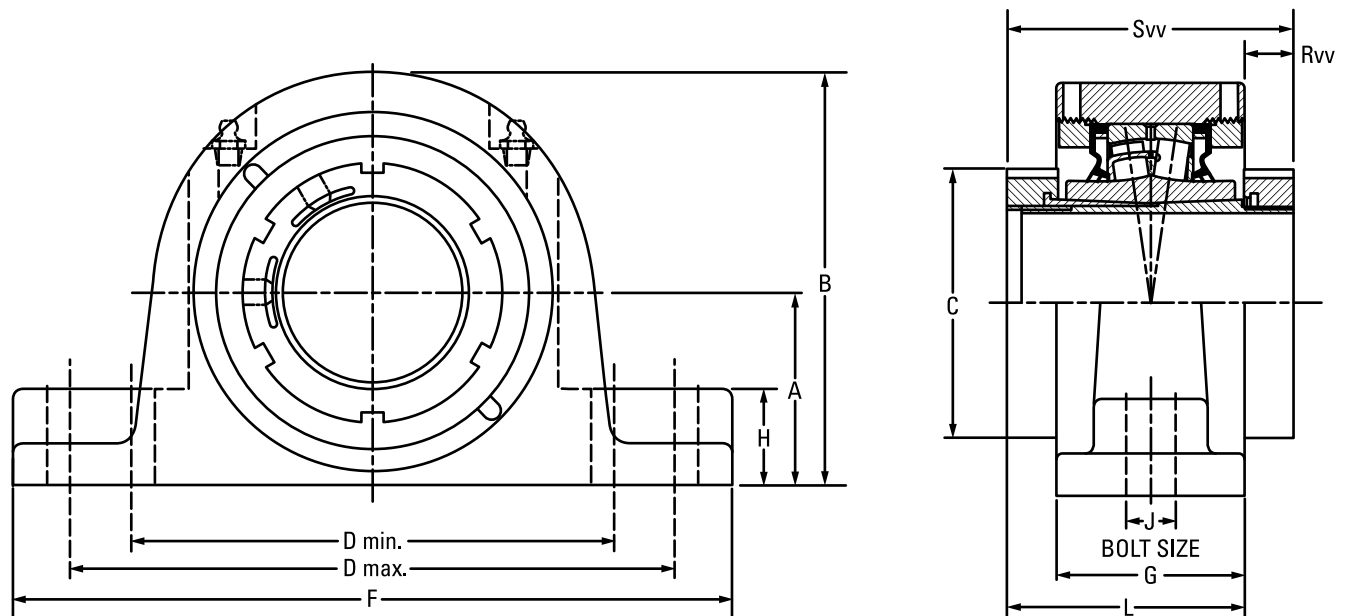

Bearing Part No. ⁽¹⁾	Shaft Dia.	Bearing No.	A	B	C	D min.	D max.	F	G	H	J	L	Rvv	Svv	Wt.
	mm in.		mm in.	mm in.	mm in.	mm in.	mm in.	mm in.	mm in.	mm in.	mm in.	mm in.	mm in.	mm in.	kg lbs.
QVVPKT13V203S	2 3/16 in.	22213	76.2	153.7	80.3	194.6	223.0	285.8	73.7	35.1	20	87.9	14.2	102.1	10.0
QVVPKT13V204S	2 1/4 in.		3.00	6.05	3.16	7.66	8.78	11.25	2.90	1.38	3/4	3.46	0.56	4.02	22
QVVPKT13V055S	55 mm														
QVVPKT15V060S	60 mm	22215	88.9	173.7	94.0	230.1	265.2	330.2	75.7	35.1	24	89.9	14.2	103.9	12.7
QVVPKT15V207S	2 7/16 in.		3.50	6.84	3.70	9.06	10.44	13.00	2.98	1.38	7/8	3.54	0.56	4.09	28
QVVPKT15V208S	2 1/2 in.														
QVVPKT15V065S	65 mm														

⁽¹⁾Double-nut (QVV) part number shown. Single-nut (QV) version available upon request.

QVVPF FOUR-BOLT PILLOW BLOCKS – STRAIGHT BORE EQUIVALENT

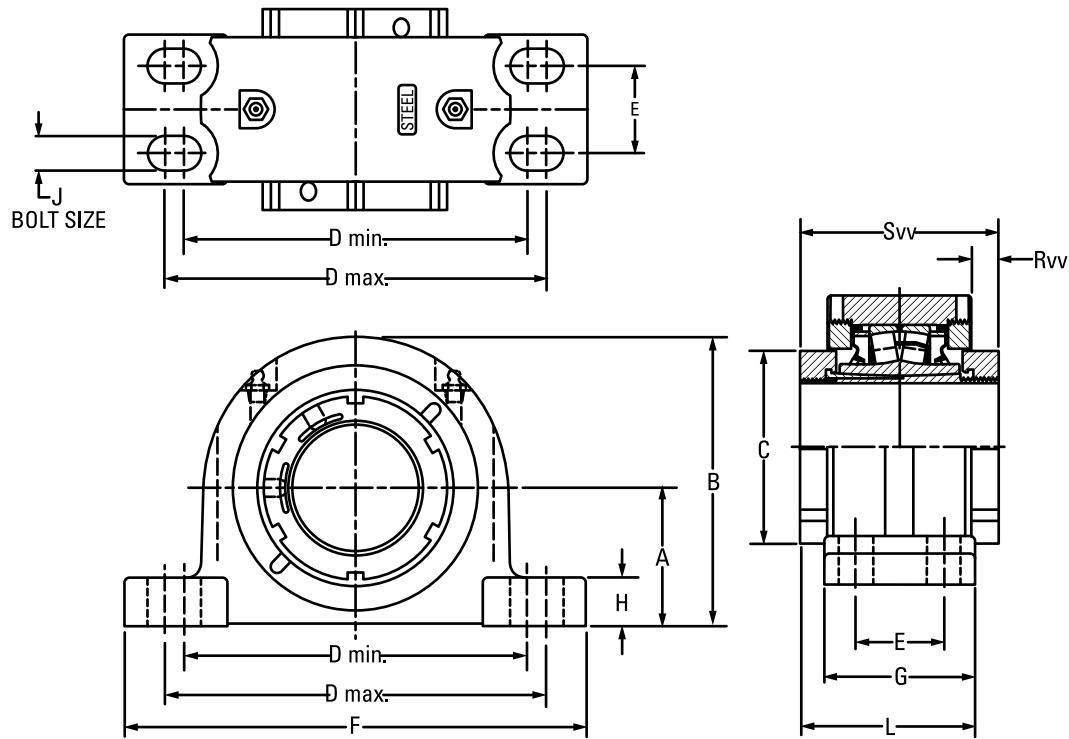

Bearing Part No. ⁽¹⁾	Shaft Dia.	Bearing No.	A	B	C	D min.	D max.	E	F	G	H	J	L	Rvv	Svv	Wt.
	mm in.		mm in.	mm in.	mm in.	mm in.	mm in.	mm in.	mm in.	mm in.	mm in.	mm in.	mm in.	mm in.	mm in.	kg lbs.
QVVPF14V060S	60 mm	22214	69.9 2.75	147.3 5.80	94.0 3.70	174.8 6.88	193.8 7.63	44.5 1.75	235.0 9.25	76.2 3.00	24.9 0.98	16 5/8	90.2 3.55	15.2 0.60	103.9 4.09	9.1 20
QVVPF14V207S	2 7/16 in.															
QVVPF14V208S	2 1/2 in.															
QVVPF14V065S	65 mm															
QVVPF16V211S	2 11/16 in.	22216	82.6 3.25	167.4 6.59	106.4 4.19	193.0 7.60	231.1 9.10	47.8 1.88	265.2 10.44	79.5 3.13	32.8 1.29	16 5/8	93.0 3.66	15.2 0.60	106.2 4.18	12.2 27
QVVPF16V212S	2 3/4 in.															
QVVPF16V070S	70 mm															
QVVPF16V215S	2 15/16 in.															
QVVPF16V300S	3 in.	22219	95.3 3.75	195.3 7.69	124.5 4.90	225.6 8.88	276.4 10.88	50.8 2.00	312.4 12.30	95.3 3.75	39.6 1.56	20 3/4	106.4 4.19	14.5 0.57	117.6 4.63	22.2 49
QVVPF16V075S	75 mm															
QVVPF19V303S	3 3/16 in.															
QVVPF19V304S	3 1/4 in.															
QVVPF19V080S	80 mm	22222	108.0 4.25	223.0 8.78	139.7 5.50	276.4 10.88	339.9 13.38	57.2 2.25	378.0 14.88	109.5 4.31	35.6 1.40	20 3/4	119.9 4.72	14.7 0.58	130.3 5.13	30.4 67
QVVPF19V085S	85 mm															
QVVPF19V307S	3 7/16 in.															
QVVPF19V308S	3 1/2 in.															
QVVPF19V090S	90 mm	22226	120.7 4.75	250.7 9.87	174.8 6.88	301.8 11.88	368.3 14.50	63.5 2.50	409.7 16.13	120.7 4.75	40.1 1.58	20 3/4	149.6 5.89	32.8 1.29	178.3 7.02	37.2 82
QVVPF22V311S	3 11/16 in.															
QVVPF22V312S	3 3/4 in.															
QVVPF22V100S	100 mm															
QVVPF22V315S	3 15/16 in.	22228	139.7 5.50	279.7 11.01	190.0 7.48	349.3 13.75	403.4 15.88	69.9 2.75	444.5 17.50	128.0 5.04	39.1 1.54	24 7/8	153.2 6.03	31.5 1.24	178.3 7.02	60.8 134
QVVPF22V400S	4 in.															
QVVPF26V110S	110 mm															
QVVPF26V407S	4 7/16 in.															
QVVPF26V408S	4 1/2 in.															
QVVPF26V115S	115 mm															
QVVPF28V125S	125 mm															
QVVPF28V415S	4 15/16 in.															
QVVPF28V500S	5 in.															
QVVPF28V130S	130 mm															

⁽¹⁾Double-nut (QVV) part number shown. Single-nut (QV) version available upon request.

QVVPR FOUR-BOLT PILLOW BLOCKS – STRAIGHT BORE EQUIVALENT

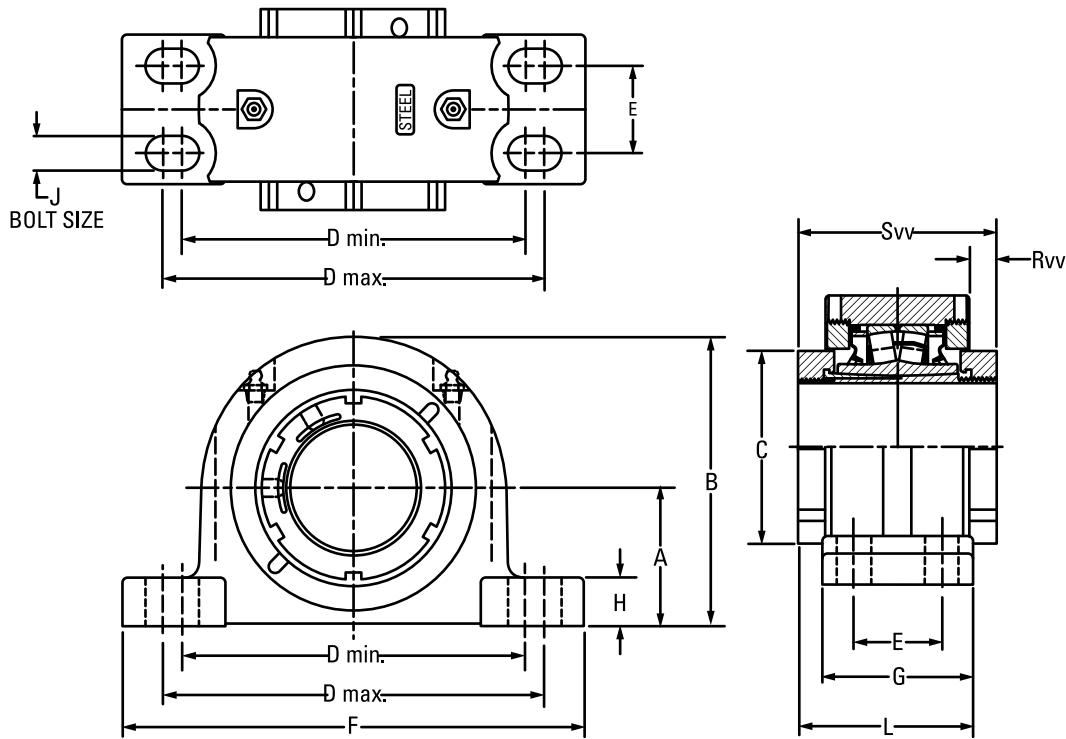

Bearing Part No. ⁽¹⁾	Shaft Dia.	Bearing No.	A	B	C	D min.	D max.	E	F	G	H	J	L	Rvv	Svv	Wt.	
			mm in.	mm in.	mm in.	mm in.	mm in.	mm in.	mm in.	mm in.	mm in.	mm in.	mm in.	mm in.	mm in.	mm in.	mm in.
QVVPR14V060S	60 mm	22214	69.9	147.3	94.0	181.1	222.2	47.8	260.4	82.6	24.9	16	93.2	15.2	103.9	9.1	
QVVPR14V207S	2 7/16 in.		2.75	5.80	3.70	7.13	8.75	1.88	10.25	3.25	0.98	5/8	3.67	0.60	4.09	20	
QVVPR14V208S	2 1/2 in.																
QVVPR14V065S	65 mm																
QVVPR16V211S	2 11/16 in.	22216	79.5	164.3	106.4	203.2	243.8	54.1	275.1	85.9	29.5	16	96.0	15.2	106.2	12.2	
QVVPR16V212S	2 3/4 in.		3.13	6.47	4.19	8.00	9.60	2.13	10.83	3.38	1.16	5/8	3.78	0.60	4.18	27	
QVVPR16V070S	70 mm																
QVVPR16V215S	2 15/16 in.																
QVVPR16V300S	3 in.																
QVVPR16V075S	75 mm																
QVVPR19V303S	3 3/16 in.	22219	95.3	195.3	124.5	235.0	285.8	60.5	346.2	95.3	39.6	20	106.4	14.5	117.6	22.2	
QVVPR19V304S	3 1/4 in.		3.75	7.69	4.90	9.25	11.25	2.38	13.63	3.75	1.56	3/4	4.19	0.57	4.63	49	
QVVPR19V080S	80 mm																
QVVPR19V085S	85 mm																
QVVPR19V307S	3 7/16 in.																
QVVPR19V308S	3 1/2 in.																
QVVPR19V090S	90 mm																

⁽¹⁾Double-nut (QVV) part number shown. Single-nut (QV) version available upon request.

QVVPX 5000 SERIES FOUR-BOLT PILLOW BLOCKS – STRAIGHT BORE EQUIVALENT

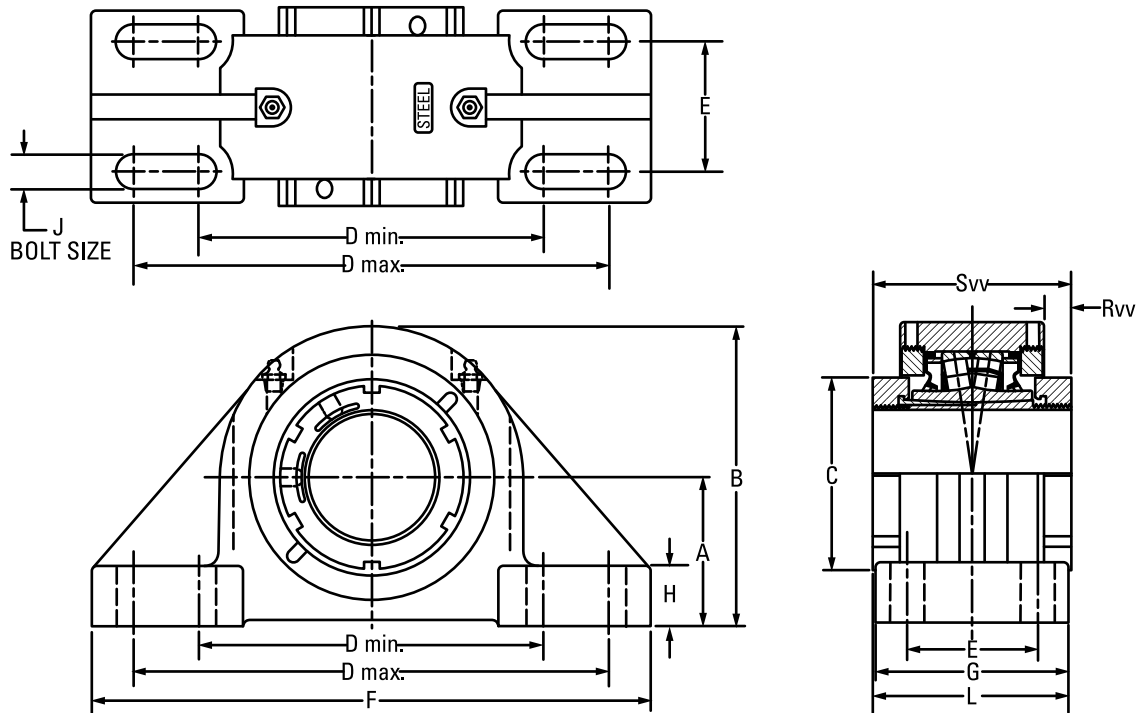

Bearing Part No. ⁽¹⁾	Shaft Dia.	Bearing No.	A	B	C	D min.	D max.	E	F	G	H	J	L	Rvv	Svv	Wt.
	mm in.		mm in.	mm in.	mm in.	mm in.	mm in.	mm in.	mm in.	mm in.	mm in.	mm in.	mm in.	mm in.	mm in.	kg lbs.
QVVPX14V060S	60 mm	22214	76.2 3.00	153.7 6.05	94.0 3.70	176.3 6.94	242.8 9.56	66.8 2.63	285.8 11.25	98.6 3.88	31.0 1.22	16 5/8	101.3 3.99	15.2 0.60	103.9 4.09	10.4 23
QVVPX14V207S	2 7/16 in.															
QVVPX14V208S	2 1/2 in.															
QVVPX14V065S	65 mm															
QVVPX16V211S	2 11/16 in.	22216	88.9 3.50	173.5 6.83	106.4 4.19	230.1 9.06	265.2 10.44	69.9 2.75	330.2 13.00	108.0 4.25	39.1 1.54	20 3/4	107.2 4.22	14.2 0.56	106.2 4.18	12.7 28
QVVPX16V212S	2 3/4 in.															
QVVPX16V070S	70 mm															
QVVPX16V215S	2 15/16 in.															
QVVPX16V300S	3 in.	22219	101.6 4.00	201.2 7.92	124.5 4.90	274.6 10.81	309.6 12.19	76.2 3.00	381.0 15.00	120.7 4.75	38.1 1.50	20 3/4	119.1 4.69	14.5 0.57	117.6 4.63	22.2 49
QVVPX16V075S	75 mm															
QVVPX19V303S	3 3/16 in.															
QVVPX19V304S	3 1/4 in.															
QVVPX19V080S	80 mm	22222	127.0 5.00	239.8 9.44	139.7 5.50	317.5 12.50	355.6 14.00	88.9 3.50	425.5 16.75	139.7 5.50	41.4 1.63	24 7/8	135.1 5.32	15.2 0.60	130.3 5.13	30.4 67
QVVPX19V085S	85 mm															
QVVPX19V307S	3 7/16 in.															
QVVPX19V308S	3 1/2 in.															
QVVPX19V090S	90 mm	22226	146.1 5.75	273.8 10.78	174.8 6.88	354.1 13.94	395.2 15.56	101.6 4.00	469.9 18.50	158.8 6.25	45.7 1.80	24 1	168.7 6.64	38.4 1.51	178.3 7.02	37.2 82
QVVPX22V311S	3 11/16 in.															
QVVPX22V312S	3 3/4 in.															
QVVPX22V315S	3 15/16 in.															
QVVPX22V400S	4 in.	22228	155.6 6.125	293.4 11.55	190.0 7.48	387.4 15.25	452.5 16.75	108.0 4.25	514.4 20.25	171.5 6.75	50.8 2.00	24 1 1/8	175.0 6.89	30.7 1.21	178.3 7.02	61.7 136
QVVPX22V100S	100 mm															
QVVPX26V110S	110 mm															
QVVPX26V407S	4 7/16 in.															
QVVPX26V408S	4 1/2 in.															
QVVPX26V115S	115 mm															
QVVPX28V125S	125 mm															
QVVPX28V415S	4 15/16 in.															
QVVPX28V500S	5 in.															
QVVPX28V130S	130 mm															

⁽¹⁾Double-nut (QVV) part number shown. Single-nut (QV) version available upon request.

QVVPXT 5000 SERIES TWO-BOLT PILLOW BLOCKS – STRAIGHT BORE EQUIVALENT

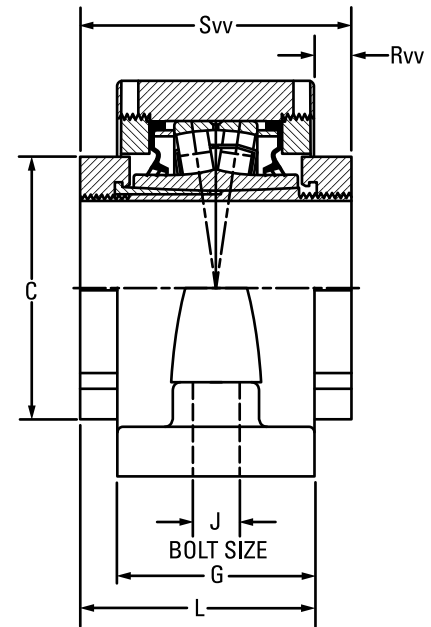
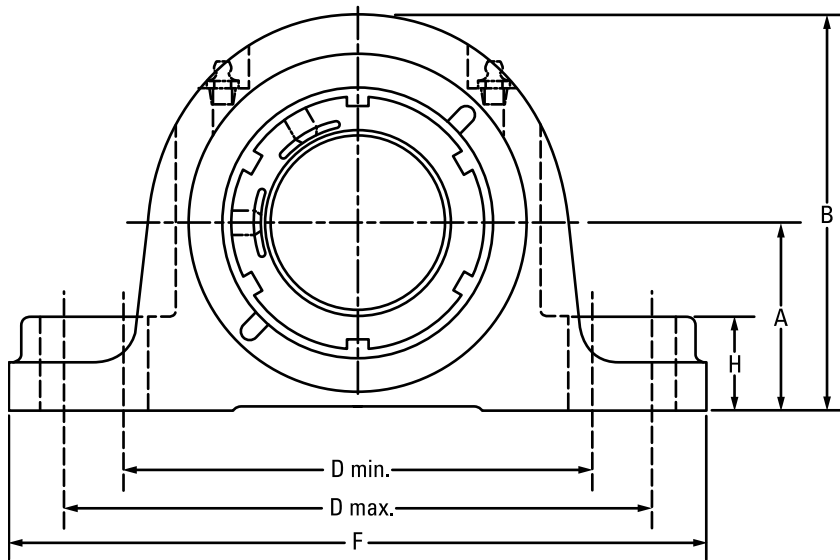

Bearing Part No. ⁽¹⁾	Shaft Dia.	Bearing No.	A	B	C	D min.	D max.	F	G	H	J	L	Rvv	Svv	Wt.
	mm in.		mm in.	mm in.	mm in.	mm in.	mm in.	mm in.	mm in.	mm in.	mm in.	mm in.	mm in.	mm in.	kg lbs.
QVVPXT14V060S	60 mm	22214	76.2 3.00	153.7 6.05	94.0 3.70	194.6 7.66	233.0 8.78	285.8 11.25	73.7 2.90	35.1 1.38	20 ¾	88.9 3.50	15.2 0.60	103.9 4.09	10.0 22
QVVPXT14V207S	2 7/16 in.														
QVVPXT14V208S	2 1/2 in.														
QVVPXT14V065S	65 mm														
QVVPXT16V211S	2 11/16 in.	22216	88.9 3.50	173.7 6.84	106.4 4.19	230.1 9.06	265.2 10.44	330.2 13.00	75.7 2.98	35.1 1.38	24 7/8	90.9 3.58	15.2 0.60	106.2 4.18	12.7 28
QVVPXT16V212S	2 3/4 in.														
QVVPXT16V070S	70 mm														
QVVPXT16V215S	2 15/16 in.														
QVVPXT16V300S	3 in.														
QVVPXT16V075S	75 mm														

⁽¹⁾Double-nut (QVV) part number shown. Single-nut (QV) version available upon request.

QVVPG SN-STYLE FOUR-BOLT PILLOW BLOCKS – TAPERED BORE EQUIVALENT

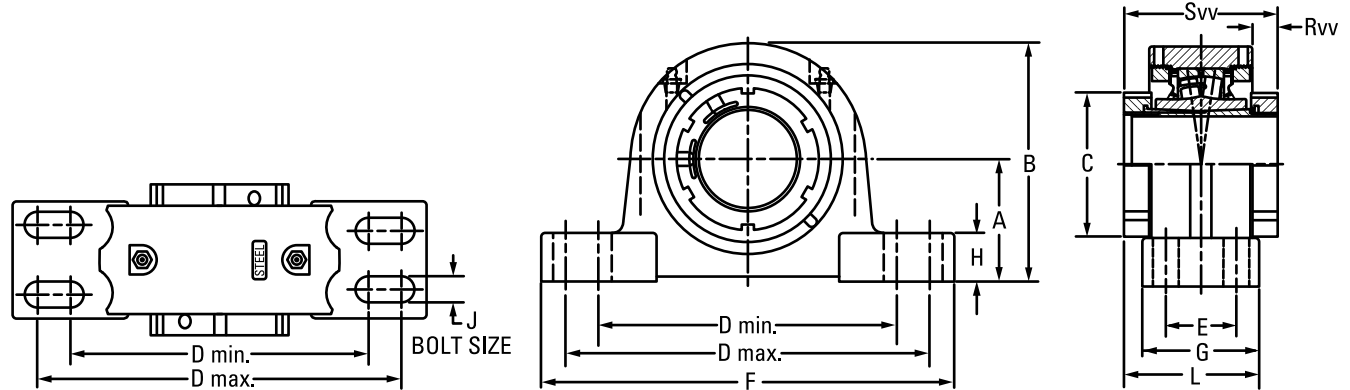

Bearing Part No. ⁽¹⁾	Shaft Dia.	Bearing No.	A	B	C	D min.	D max.	E	F	G	H	J	L	Rvv	Svv	Wt.	
	mm in.		mm in.	mm in.	mm in.	mm in.	mm in.	mm in.	mm in.	mm in.	mm in.	mm in.	mm in.	mm in.	mm in.	kg lbs.	
QVVPG11V115S	1 15/16 in.	22211	69.9	134.9	75.9	182.4	217.4	39.9	251.0	68.6	31.8	16	85.3	20.8	102.1	8.6	
QVVPG11V200S	2 in.		2.75	5.31	2.99	7.18	8.56	1.57	9.88	2.70	1.25	5/8	3.36	0.82	4.02	19	
QVVPG11V050S	50 mm																
QVVPG12V055S	55 mm	22212	70.0	140.5	80.0	177.8	219.2	35.1	254.0	69.9	31.8	12	86.1	20.8	102.1	9.9	
			2.756	5.53	3.15	7.00	8.63	1.38	10.00	2.75	1.25	1/2	3.39	0.82	4.02	22	
QVVPG13V203S	2 3/16 in.	22213	80.0	154.9	80.3	182.4	217.4	48.0	261.9	82.6	35.1	16	92.5	17.0	102.1	11.3	
QVVPG13V204S	2 1/4 in.		3.15	6.10	3.16	7.18	8.56	1.89	10.31	3.25	1.38	5/8	3.64	0.67	4.02	25	
QVVPG14V060S	60 mm	22214	80.0	154.9	94.0	182.4	217.4	48.0	261.9	82.6	35.1	16	93.2	86.1	103.9	11.3	
			3.15	6.10	3.70	7.18	8.56	1.89	10.31	3.25	1.38	5/8	3.67	3.39	4.09	25	
QVVPG15V207S	2 7/16 in.	22215	80.0	162.1	94.0	201.7	246.1	39.6	276.4	79.5	30.2	16	91.7	15.7	103.9	13.2	
QVVPG15V208S	2 1/2 in.		3.15	6.38	3.70	7.94	9.69	1.56	10.88	3.13	1.19	5/8	3.61	0.62	4.09	29	
QVVPG15V065S	65 mm																
QVVPG16V211S	2 11/16 in.	22216	95.0	180.3	105.9	235.0	266.7	50.0	315.0	89.9	31.8	16	98.0	16.8	105.9	14.9	
QVVPG16V212S	2 3/4 in.		3.74	7.10	4.17	9.25	10.50	1.97	12.4	3.54	1.25	5/8	3.86	0.66	4.17	33	
QVVPG16V070S	70 mm																
QVVPG17V215S	2 15/16 in.	22217	95.0	182.9	106.4	240.0	287.3	52.3	320.8	92.2	31.8	20	99.3	15.0	106.2	16.8	
QVVPG17V300S	3 in.		3.74	7.20	4.19	9.44	11.31	2.06	12.63	3.63	1.25	3/4	3.91	0.59	4.18	37	
QVVPG17V075S	75 mm																
QVVPG19V303S	3 3/16 in.	22219	100.0	195.3	124.0	282.7	298.5	50.0	344.9	100.1	39.6	16	109.2	19.3	118.1	24.5	
QVVPG19V304S	3 1/4 in.		3.937	7.69	4.88	11.13	11.75	1.97	13.58	3.94	1.56	5/8	4.30	0.76	4.65	54	
QVVPG19V080S	80 mm																
QVVPG19V085S	85 mm	22219	112.0	212.3	124.0	282.7	298.5	50.0	344.9	100.1	39.6	16	109.2	17.8	118.1	25.4	
			4.409	8.36	4.88	11.13	11.75	1.97	13.58	3.94	1.56	5/8	4.30	0.70	4.65	56	
QVVPG20V307S	3 7/16 in.	22220	112.0	214.6	124.5	276.4	339.9	60.5	381.0	109.5	39.6	20	113.5	11.2	117.6	31.8	
QVVPG20V308S	3 1/2 in.		4.409	8.45	4.90	10.88	13.38	2.38	15.00	4.31	1.56	3/4	4.47	0.44	4.63	70	
QVVPG20V090S	90 mm																
QVVPG22V311S	3 11/16 in.	22222	125.0	238.3	139.7	301.8	368.3	69.9	409.7	120.7	44.5	20	125.5	14.5	130.3	39.5	
QVVPG22V312S	3 3/4 in.		4.921	9.38	5.50	11.88	14.50	2.75	16.13	4.75	1.75	3/4	4.94	0.57	5.13	87	
QVVPG22V100S	100 mm																
QVVPG22V315S	3 15/16 in.																
QVVPG22V400S	4 in.																
QVVPG24V110S	110 mm	22224	140.0	262.9	174.8	342.9	355.6	70.1	410.0	120.7	50.8	16	149.6	40.4	178.3	49.9	
			5.512	10.35	6.88	13.50	14.00	2.76	16.14	4.75	2.00	5/8	5.89	1.59	7.02	110	
QVVPG26V407S	4 7/16 in.	22226	150.0	281.7	174.8	367.3	400.1	81.0	444.5	128.0	49.3	24	153.2	36.6	178.3	61.7	
QVVPG26V408S	4 1/2 in.		5.906	11.09	6.88	14.46	15.75	3.19	17.50	5.04	1.94	1	6.03	1.44	7.02	136	
QVVPG26V115S	115 mm																
QVVPG28V125S	125 mm	22228	150.0	288.5	190.0	384.3	447.8	80.0	500.4	128.0	49.3	24	152.9	31.8	178.3	61.7	
QVVPG28V415S	4 15/16 in.		5.906	11.36	7.48	15.13	17.63	3.15	19.70	5.04	1.94	1	6.02	1.25	7.02	136	
QVVPG28V500S	5 in.																
QVVPG28V130S	130 mm																

⁽¹⁾Double-nut (QVV) part number shown. Single-nut (QV) version available upon request.

QVVPH SAF-STYLE FOUR-BOLT PILLOW BLOCKS – TAPERED BORE EQUIVALENT

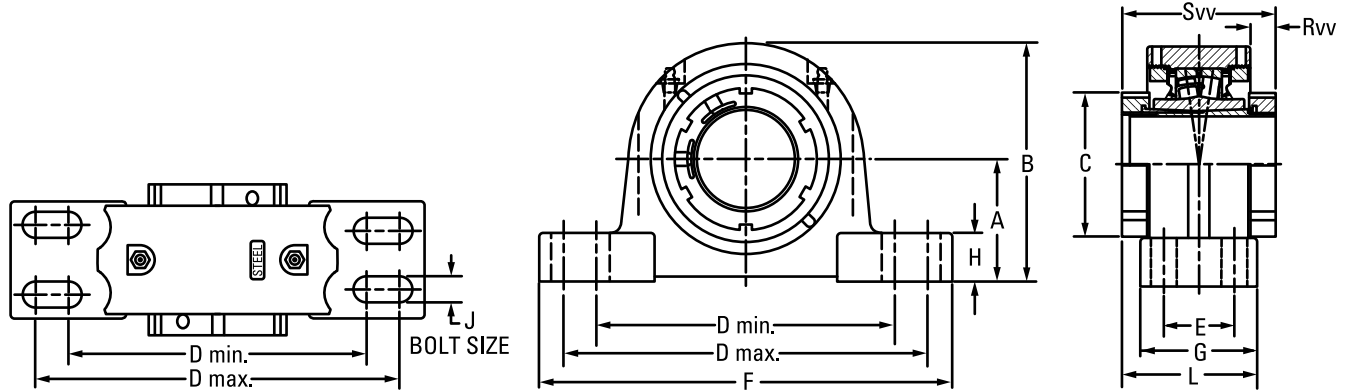

Bearing Part No. ⁽¹⁾	Shaft Dia.	Bearing No.	A	B	C	D min.	D max.	E	F	G	H	J	L	Rvv	Svv	Wt.
	mm in.		mm in.	mm in.	mm in.	mm in.	mm in.	mm in.	mm in.	mm in.	mm in.	mm in.	mm in.	mm in.	mm in.	kg lbs.
QVVPH11V115S	1 15/16 in.	22211	69.9	134.9	75.9	182.4	217.4	39.9	251.0	68.6	31.8	16	85.3	20.8	102.1	8.6
QVVPH11V200S	2 in.		2.75	5.31	2.99	7.18	8.56	1.57	9.88	2.70	1.25	5/8	3.36	0.82	4.02	19
QVVPH11V050S	50 mm															
QVVPH13V203S	2 3/16 in.	22213	76.2	151.1	80.3	182.4	217.4	50.8	261.9	82.6	31.2	12	92.5	17.0	102.1	11.3
QVVPH13V204S	2 1/4 in.		3.00	5.95	3.16	7.18	8.56	2.00	10.31	3.25	1.23	1/2	3.64	0.67	4.02	25
QVVPH13V055S	55 mm															
QVVPH15V060S	60 mm	22215	82.6	162.1	94.0	201.7	246.1	47.8	276.4	79.5	32.8	12	91.7	18.0	103.9	13.2
QVVPH15V207S	2 7/16 in.		3.25	6.38	3.70	7.94	9.69	1.88	10.88	3.13	1.29	1/2	3.61	0.71	4.09	29
QVVPH15V208S	2 1/2 in.															
QVVPH15V065S	65 mm	22217	95.3	182.9	106.4	240.0	287.3	54.1	320.8	92.2	32.0	16	99.3	15.0	106.2	16.8
QVVPH17V211S	2 11/16 in.		3.75	7.20	4.19	9.44	11.31	2.13	12.63	3.63	1.26	5/8	3.91	0.59	4.18	37
QVVPH17V212S	2 3/4 in.															
QVVPH17V070S	70 mm	22220	114.3	216.9	124.5	276.4	339.9	60.5	381.0	109.5	41.9	20	113.5	11.2	117.6	31.8
QVVPH17V215S	2 15/16 in.		4.50	8.54	4.90	10.88	13.38	2.38	15.00	4.31	1.65	3/4	4.47	0.44	4.63	70
QVVPH17V300S	3 in.															
QVVPH17V075S	75 mm	22222	125.5	238.3	139.7	301.8	368.3	69.9	406.4	120.7	45.0	20	125.5	14.5	130.3	39.5
QVVPH20V303S	3 3/16 in.		4.94	9.38	5.50	11.88	14.50	2.75	16.00	4.75	1.77	3/4	4.94	0.57	5.13	87
QVVPH20V304S	3 1/4 in.															
QVVPH20V080S	80 mm	22226	152.4	284.0	174.8	362.0	400.1	82.6	444.5	128.0	51.8	22	153.2	36.6	178.3	61.7
QVVPH20V085S	85 mm		6.00	11.18	6.88	14.25	15.75	3.25	17.50	5.04	2.04	7/8	6.03	1.44	7.02	136
QVVPH20V307S	3 7/16 in.															
QVVPH20V308S	3 1/2 in.	22228	152.4	290.8	190.0	406.4	435.1	85.9	500.4	128.0	51.8	24	152.9	31.8	178.3	61.7
QVVPH20V090S	90 mm		6.00	11.45	7.48	16.00	17.13	3.38	19.70	5.04	2.04	1	6.02	1.25	7.02	136
QVVPH22V311S	3 11/16 in.															
QVVPH22V312S	3 3/4 in.	22226	152.4	284.0	174.8	362.0	400.1	82.6	444.5	128.0	51.8	22	153.2	36.6	178.3	61.7
QVVPH22V100S	100 mm		6.00	11.18	6.88	14.25	15.75	3.25	17.50	5.04	2.04	7/8	6.03	1.44	7.02	136
QVVPH22V315S	3 15/16 in.															
QVVPH22V400S	4 in.	22228	152.4	290.8	190.0	406.4	435.1	85.9	500.4	128.0	51.8	24	152.9	31.8	178.3	61.7
QVVPH26V110S	110 mm		6.00	11.45	7.48	16.00	17.13	3.38	19.70	5.04	2.04	1	6.02	1.25	7.02	136
QVVPH26V407S	4 7/16 in.															
QVVPH26V408S	4 1/2 in.	22228	152.4	290.8	190.0	406.4	435.1	85.9	500.4	128.0	51.8	24	152.9	31.8	178.3	61.7
QVVPH26V115S	115 mm		6.00	11.45	7.48	16.00	17.13	3.38	19.70	5.04	2.04	1	6.02	1.25	7.02	136
QVVPH28V125S	125 mm															
QVVPH28V415S	4 15/16 in.	22228	152.4	290.8	190.0	406.4	435.1	85.9	500.4	128.0	51.8	24	152.9	31.8	178.3	61.7
QVVPH28V500S	5 in.		6.00	11.45	7.48	16.00	17.13	3.38	19.70	5.04	2.04	1	6.02	1.25	7.02	136
QVVPH28V130S	130 mm															

⁽¹⁾Double-nut (QVV) part number shown. Single-nut (QV) version available upon request.

QVVPK 9000 SERIES FOUR-BOLT PILLOW BLOCKS – TAPERED BORE EQUIVALENT

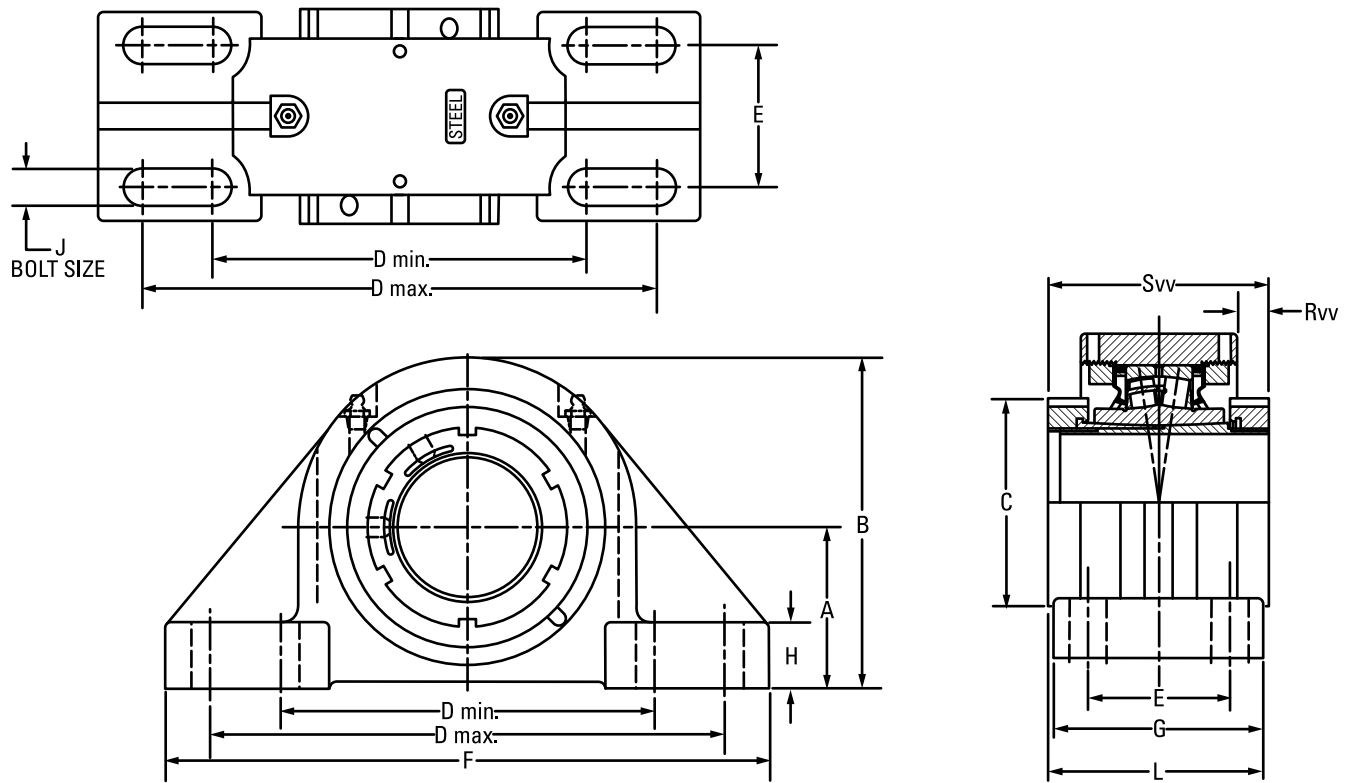

Bearing Part No. ⁽¹⁾	Shaft Dia.	Bearing No.	A	B	C	D min.	D max.	E	F	G	H	J	L	Rvv	Svv	Wt.
	mm in.		mm in.	mm in.	mm in.	mm in.	mm in.	mm in.	mm in.	mm in.	mm in.	mm in.	mm in.	mm in.	mm in.	kg lbs.
QVVPK15V060S	60 mm	22215	88.9 3.50	176.0 6.83	94.0 3.70	230.1 9.06	265.2 10.44	69.9 2.75	330.2 13.00	108.0 4.25	39.1 1.54	20 ¾	105.9 4.17	12.6 0.51	103.9 4.09	13.2 29
QVVPK15V207S	2 7/16 in.															
QVVPK15V208S	2 1/2 in.															
QVVPK15V065S	65 mm															
QVVPK17V211S	2 11/16 in.	22217	101.6 4.00	201.2 7.92	106.4 4.19	274.6 10.81	309.6 12.19	76.2 3.00	381.0 15.00	120.7 4.75	38.1 1.50	20 ¾	113.5 4.47	8.64 0.34	106.2 4.18	16.8 37
QVVPK17V212S	2 ¾ in.															
QVVPK17V070S	70 mm															
QVVPK17V215S	2 15/16 in.															
QVVPK17V300S	3 in.	22220	127.0 5.00	240.0 9.44	124.5 4.90	317.5 12.50	355.6 14.00	88.9 3.50	425.5 16.75	139.7 5.50	41.4 1.63	24 7/8	128.8 5.07	8.9 0.35	117.6 4.63	31.8 70
QVVPK17V075S	75 mm															
QVVPK20V303S	3 3/16 in.															
QVVPK20V304S	3 1/4 in.															
QVVPK20V080S	80 mm	22222	146.1 5.75	273.8 10.78	139.7 5.50	354.1 13.94	395.2 15.56	101.6 4.00	469.9 18.50	158.8 6.25	45.7 1.80	24 1	138.4 5.45	14.5 0.57	130.3 5.13	39.5 87
QVVPK20V085S	85 mm															
QVVPK20V307S	3 7/16 in.															
QVVPK20V308S	3 1/2 in.															
QVVPK20V090S	90 mm	22226	155.7 6.13	283.2 11.15	174.8 6.88	387.4 15.25	425.5 16.75	108.0 4.25	514.4 20.25	171.5 6.75	50.8 2.00	24 1	175.3 6.90	31.5 1.24	178.3 7.02	61.7 136
QVVPK22V311S	3 11/16 in.															
QVVPK22V312S	3 ¾ in.															
QVVPK22V100S	100 mm															
QVVPK22V315S	3 15/16 in.															
QVVPK22V400S	4 in.															
QVVPK26V110S	110 mm															
QVVPK26V407S	4 7/16 in.															
QVVPK26V408S	4 1/2 in.															
QVVPK26V115S	115 mm															

⁽¹⁾Double-nut (QVV) part number shown. Single-nut (QV) version available upon request.

QVF AND QVVF SQUARE FLANGE BLOCKS – STRAIGHT BORE EQUIVALENT

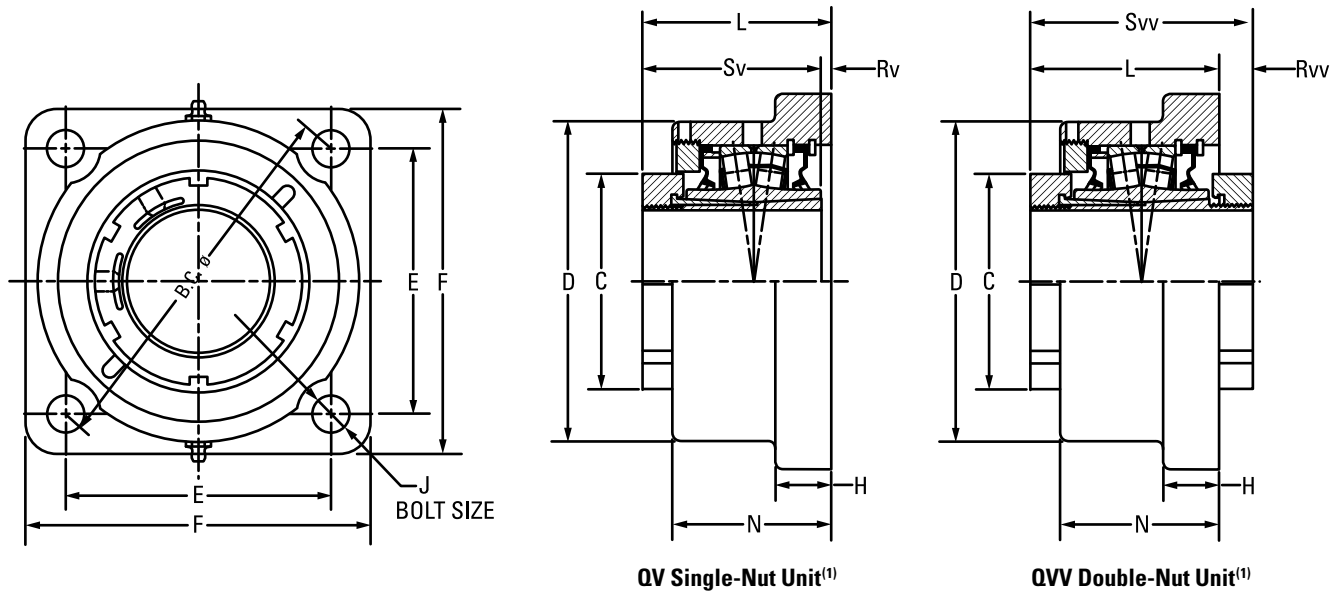

Bearing Part No. ⁽¹⁾⁽²⁾	Shaft Dia.	Bearing No.	C	D	E	B.C.	F	H	J	L FIX	L EXP	N	Rv ⁽¹⁾	Rvv	Sv ⁽¹⁾	Svv	Wt.
	mm in.		mm in.	mm in.	mm in.	mm in.	mm in.	mm in.	mm in.	mm in.	mm in.	mm in.	mm in.	mm in.	mm in.	mm in.	kg lbs.
QVF11V115S	1 15/16 in.	22211	75.9	120.7	111.3	157.0	139.7	22.4	12	84.1	86.1	65.0	4.1	18.3	79.8	102.1	5.0
QVF11V200S	2 in.		2.99	4.75	4.38	6.18	5.50	0.88	1/2	3.31	3.39	2.56	0.16	0.72	3.14	4.02	11
QVF11V050S	50 mm																
QVF12V203S	2 3/16 in.	22212	80.3	130.3	124.0	175.0	157.2	25.4	16	84.3	86.4	66.8	4.6	17.8	79.8	102.1	6.4
QVF12V204S	2 1/4 in.		3.16	5.13	4.88	6.89	6.19	1.00	5/8	3.32	3.40	2.63	0.18	0.70	3.14	4.02	14
QVF12V055S	55 mm																
QVF14V060S	60 mm	22214	94.0	146.1	136.7	193.0	168.4	25.4	16	85.1	87.1	72.4	4.1	16.0	81.0	101.3	7.7
QVF14V207S	2 7/16 in.		3.70	5.75	5.38	7.60	6.63	1.00	5/8	3.35	3.43	2.85	0.16	0.63	3.19	3.99	17
QVF14V208S	2 1/2 in.																
QVF14V065S	65 mm																
QVF16V211S	2 11/16 in.	22216	106.4	168.9	152.4	215.4	189.0	26.9	20	87.6	89.7	75.7	4.1	16.3	83.6	103.6	10.4
QVF16V212S	2 3/4 in.		4.19	6.65	6.00	8.48	7.44	1.06	3/4	3.45	3.53	2.98	0.16	0.64	3.29	4.08	23
QVF16V070S	70 mm																
QVF16V215S	2 15/16 in.																
QVF16V300S	3 in.																
QVF16V075S	75 mm																
QVF19V303S	3 3/16 in.	22219	124.5	193.8	177.8	251.7	219.2	33.3	20	98.3	100.3	84.1	4.6	15.7	93.7	114.0	15.9
QVF19V304S	3 1/4 in.		4.90	7.63	7.00	9.91	8.63	1.31	3/4	3.87	3.95	3.31	0.18	0.62	3.69	4.49	35
QVF19V080S	80 mm																
QVF19V085S	85 mm																
QVF19V307S	3 7/16 in.																
QVF19V308S	3 1/2 in.																
QVF19V090S	90 mm																
QVF22V311S	3 11/16 in.	22222	139.7	224.0	196.9	278.4	253.2	38.1	24	114.0	116.1	103.1	9.1	12.7	104.9	126.7	24.9
QVF22V312S	3 3/4 in.		5.50	8.82	7.75	10.96	9.97	1.50	7/8	4.49	4.57	4.06	0.36	0.50	4.13	4.99	55
QVF22V100S	100 mm																
QVF22V315S	3 15/16 in.																
QVF22V400S	4 in.																
QVF26V110S	110 mm	22226	174.8	256.8	222.3	314.5	276.4	38.1	24	140.5	142.7	106.9	7.4	37.8	147.8	178.3	28.6
QVF26V407S	4 7/16 in.		6.88	10.11	8.75	12.38	10.88	1.50	7/8	5.53	5.62	4.21	0.29	1.49	5.82	7.02	63
QVF26V408S	4 1/2 in.																
QVF26V115S	115 mm																

⁽¹⁾Bearing part numbers use QV to designate single-nut units (uses Rv and Sv dimensions) and QVV to designate double-nut units (uses Rvv and Sv dimensions).

⁽²⁾Single-nut (QV) part number shown. Double-nut (QVV) version available upon request.

QVFB AND QVFB FLANGE BLOCKS – TAPERED ADAPTER EQUIVALENT

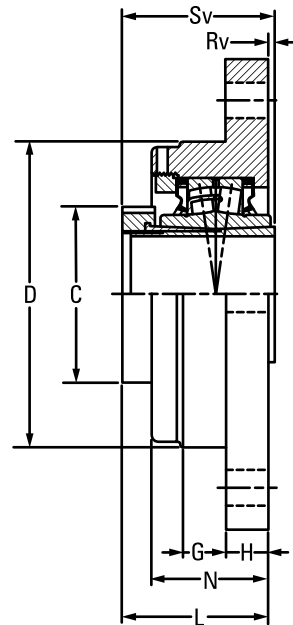
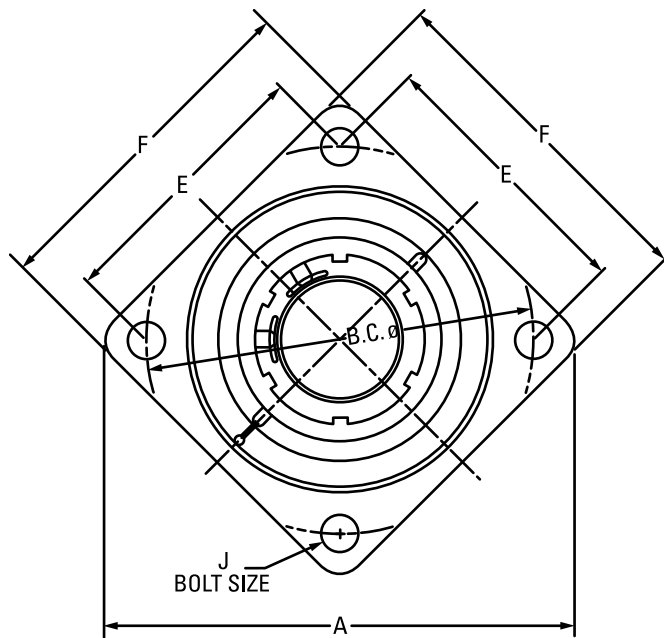

QV Single-Nut Unit⁽¹⁾

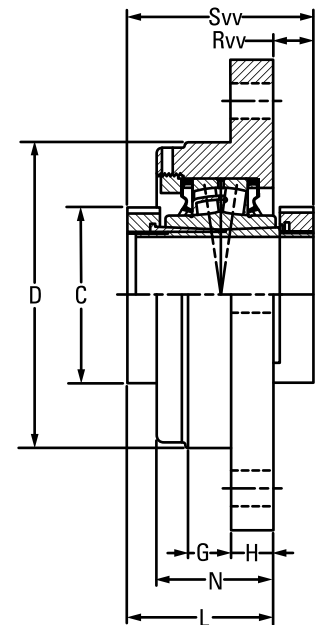

QVV Double-Nut Unit⁽¹⁾

Bearing Part No. ⁽¹⁾⁽²⁾	Shaft Dia.	Bearing No.	A	B.C.	C	D	E	F	G	H	J	L	N	Rv ⁽¹⁾	Rvv	Sv ⁽¹⁾	Svv	Wt.
	mm in.		mm in.	mm in.	mm in.	mm in.	mm in.	mm in.	mm in.	mm in.	mm in.	mm in.	mm in.	mm in.	mm in.	mm in.	mm in.	kg lbs.
QVFB15V060S	60 mm	22215	255.0 10.04	215.1 8.47	94.0 3.70	169.9 6.69	152.4 6.00	192.0 7.56	25.4 1.00	23.9 0.94	16 5/8	81.5 3.21	64.8 2.55	0.8 0.03	22.4 0.88	82.6 3.25	103.9 4.09	11.3 25
QVFB15V207S	2 7/16 in.																	
QVFB15V208S	2 1/2 in.																	
QVFB15V065S	65 mm	22217	282.4 11.12	240.0 9.45	106.4 4.19	190.0 7.48	169.7 6.68	212.1 8.35	25.4 1.00	25.4 1.00	16 5/8	83.8 3.30	69.9 2.75	1.0 0.04	22.4 0.88	84.6 3.33	106.2 4.18	13.6 30
QVFB17V211S	2 11/16 in.																	
QVFB17V212S	2 3/4 in.																	
QVFB17V070S	70 mm	22220	330.2 13.00	279.9 11.02	124.5 4.90	230.1 9.06	197.9 7.79	247.9 9.76	31.8 1.25	28.7 1.13	20 3/4	106.7 4.20	94.2 3.71	11.4 0.45	10.9 0.43	95.3 3.75	117.3 4.62	18.1 40
QVFB17V300S	3 in.																	
QVFB17V075S	75 mm																	
QVFB20V303S	3 3/16 in.	22222	367.0 14.45	309.9 12.20	139.7 5.50	255.0 10.04	219.2 8.63	274.3 10.80	44.5 1.75	26.4 1.04	20 3/4	112.0 4.41	101.1 3.98	7.4 0.29	14.7 0.58	104.9 4.13	126.7 4.99	27.2 60
QVFB20V304S	3 1/4 in.																	
QVFB20V080S	80 mm																	
QVFB20V085S	85 mm	22226	416.1 16.38	355.1 13.98	174.8 6.88	290.1 11.42	251.0 9.88	298.5 11.75	41.9 1.65	32.0 1.26	24 7/8	148.3 5.84	114.3 4.50	0.5 0.02	30.0 1.18	147.8 5.82	178.3 7.02	42.6 94
QVFB20V307S	3 7/16 in.																	
QVFB20V308S	3 1/2 in.																	
QVFB20V090S	90 mm	22226	416.1 16.38	355.1 13.98	174.8 6.88	290.1 11.42	251.0 9.88	298.5 11.75	41.9 1.65	32.0 1.26	24 7/8	148.3 5.84	114.3 4.50	0.5 0.02	30.0 1.18	147.8 5.82	178.3 7.02	42.6 94
QVFB22V311S	3 11/16 in.																	
QVFB22V312S	3 3/4 in.																	
QVFB22V100S	100 mm	22226	416.1 16.38	355.1 13.98	174.8 6.88	290.1 11.42	251.0 9.88	298.5 11.75	41.9 1.65	32.0 1.26	24 7/8	148.3 5.84	114.3 4.50	0.5 0.02	30.0 1.18	147.8 5.82	178.3 7.02	42.6 94
QVFB22V315S	3 15/16 in.																	
QVFB22V400S	4 in.																	
QVFB26V110S	110 mm	22226	416.1 16.38	355.1 13.98	174.8 6.88	290.1 11.42	251.0 9.88	298.5 11.75	41.9 1.65	32.0 1.26	24 7/8	148.3 5.84	114.3 4.50	0.5 0.02	30.0 1.18	147.8 5.82	178.3 7.02	42.6 94
QVFB26V407S	4 7/16 in.																	
QVFB26V408S	4 1/2 in.																	
QVFB26V115S	115 mm	22226	416.1 16.38	355.1 13.98	174.8 6.88	290.1 11.42	251.0 9.88	298.5 11.75	41.9 1.65	32.0 1.26	24 7/8	148.3 5.84	114.3 4.50	0.5 0.02	30.0 1.18	147.8 5.82	178.3 7.02	42.6 94
QVFB26V407S	4 7/16 in.																	
QVFB26V408S	4 1/2 in.																	
QVFB26V115S	115 mm	22226	416.1 16.38	355.1 13.98	174.8 6.88	290.1 11.42	251.0 9.88	298.5 11.75	41.9 1.65	32.0 1.26	24 7/8	148.3 5.84	114.3 4.50	0.5 0.02	30.0 1.18	147.8 5.82	178.3 7.02	42.6 94
QVFB26V407S	4 7/16 in.																	
QVFB26V408S	4 1/2 in.																	

⁽¹⁾Bearing part numbers use QV to designate single-nut units (uses Rv and Sv dimensions) and QVV to designate double-nut units (uses Rvv and Sv dimensions).

⁽²⁾Single-nut (QV) part number shown. Double-nut (QVV) version available upon request.

QVFC AND QVFC PILOTED FLANGE CARTRIDGES – TAPERED ADAPTER EQUIVALENT

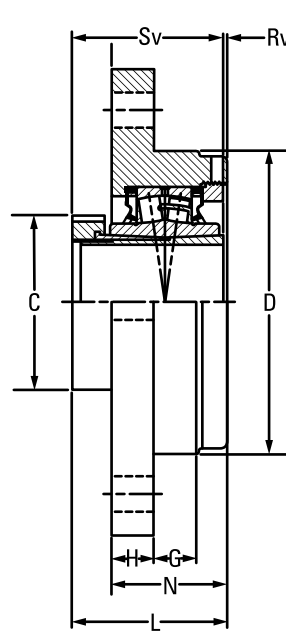
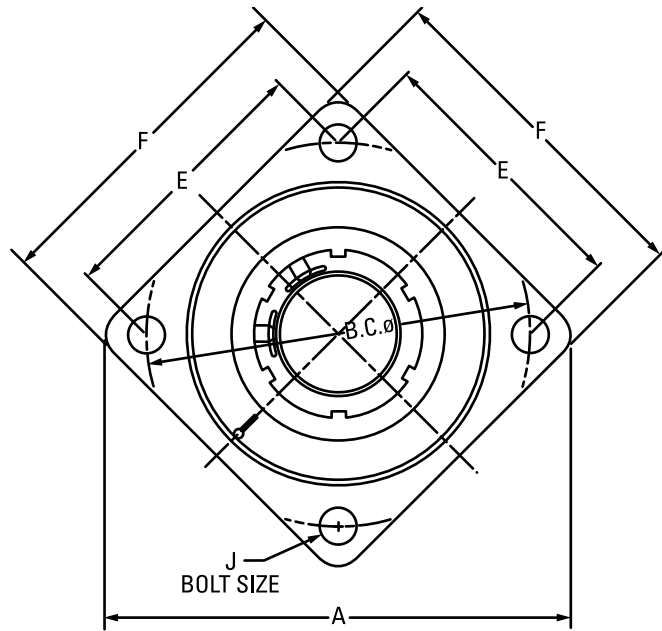

QV Single-Nut Unit⁽¹⁾

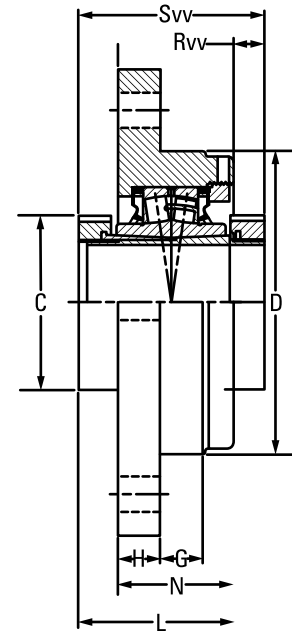

QVV Double-Nut Unit⁽¹⁾

Bearing Part No. ⁽¹⁾⁽²⁾	Shaft Dia.	Bearing No.	A	B.C.	C	D ⁽³⁾	E	F	G	H	J	L	N	Rv ⁽¹⁾	Rvv	Sv ⁽¹⁾	Svv	Wt.	
			mm in.	mm in.	mm in.	mm in.	mm in.	mm in.	mm in.	mm in.	mm in.	mm in.	mm in.	mm in.	mm in.	mm in.	mm in.	mm in.	mm in.
QVFC15V060S	60 mm	22215	255.0 10.04	215.1 8.47	94.0 3.70	169.9 6.690	152.4 6.00	192.0 7.56	25.4 1.00	23.9 0.94	16 5/8	87.1 3.43	64.8 2.55	4.6 0.18	16.8 0.66	82.6 3.25	103.9 4.09	11.3 25	
QVFC15V207S	2 7/16 in.																		
QVFC15V208S	2 1/2 in.																		
QVFC15V065S	65 mm																		
QVFC17V211S	2 11/16 in.	22217	282.4 11.12	240.0 9.45	106.4 4.19	190.0 7.480	169.7 6.68	212.1 8.35	25.4 1.00	25.4 1.00	16 5/8	91.7 3.61	69.9 2.75	6.6 0.26	14.5 0.57	84.6 3.33	106.2 4.18	13.6 30	
QVFC17V212S	2 3/4 in.																		
QVFC17V070S	70 mm																		
QVFC17V215S	2 15/16 in.																		
QVFC17V300S	3 in.	22220	330.2 13.00	279.9 11.02	124.5 4.90	230.1 9.060	197.9 7.79	247.9 9.76	31.8 1.25	28.7 1.13	20 3/4	105.2 4.14	94.2 3.71	9.7 0.38	12.4 0.49	95.3 3.75	117.3 4.62	18.1 40	
QVFC17V075S	75 mm																		
QVFC20V303S	3 3/16 in.																		
QVFC20V304S	3 1/4 in.																		
QVFC20V080S	80 mm	22222	367.0 14.45	309.9 12.20	139.7 5.50	255.0 10.040	219.2 8.63	274.3 10.80	44.5 1.75	26.4 1.04	20 3/4	112.8 4.44	101.1 3.98	8.1 0.32	5.8 0.23	104.9 4.13	126.7 4.99	27.2 60	
QVFC20V085S	85 mm																		
QVFC20V307S	3 7/16 in.																		
QVFC20V308S	3 1/2 in.																		
QVFC20V090S	90 mm	22226	416.1 16.38	355.1 13.98	174.8 6.88	290.0 11.417	251.0 9.88	298.5 11.75	41.9 1.65	32.0 1.26	24 7/8	144.3 5.68	114.3 4.50	3.6 0.14	34.0 1.34	147.8 5.82	178.3 7.02	42.6 94	
QVFC22V311S	3 11/16 in.																		
QVFC22V312S	3 3/4 in.																		
QVFC22V100S	100 mm																		
QVFC26V407S	4 7/16 in.																		
QVFC26V408S	4 1/2 in.																		
QVFC26V115S	115 mm																		

⁽¹⁾Bearing part numbers use QV to designate single-nut units (uses Rv and Sv dimensions) and QVV to designate double-nut units (uses Rvv and Sv dimensions).

⁽²⁾Single-nut (QV) part number shown. Double-nut (QVV) version available upon request.

⁽³⁾Pilot tolerance: +0/-0.05 mm (+0/-0.002 in.).

QVFL AND QVVFL SQUARE FLANGE BLOCKS – STRAIGHT BORE EQUIVALENT

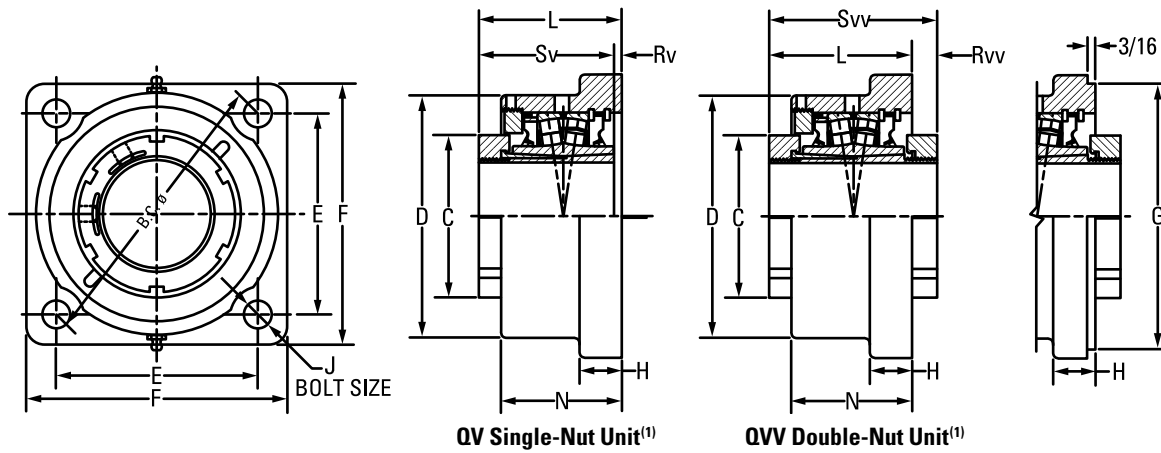

Bearing Part No. ⁽¹⁾⁽²⁾	Shaft Dia.	Bearing No.	C	D	E	B.C.	F	G ⁽³⁾⁽⁴⁾⁽⁵⁾	H	J	L FIX	L EXP	N	Rv ⁽¹⁾	Rvv	Sv ⁽¹⁾	Svv	Wt.
	mm in.		mm in.	mm in.	mm in.	mm in.	mm in.	mm in.	mm in.	mm in.	mm in.	mm in.	mm in.	mm in.	mm in.	mm in.	mm in.	kg lbs.
QVFL11V115S	1 15/16 in.	22211	75.9	115.3	103.4	146.1	131.8	N/A	23.1	12	82.6	84.6	61.2	2.5	19.8	79.8	102.1	5.0
QVFL11V200S	2 in.		2.99	4.54	4.07	5.75	5.19	0.91	1/2	3.25	3.33	2.41	0.10	0.78	3.14	4.02	11	
QVFL11V050S	50 mm																	
QVFL12V203S	2 3/16 in.	22212	80.3	130.3	114.6	162.1	149.4	N/A	19.1	16	84.3	86.4	66.8	4.6	17.8	79.8	102.1	6.4
QVFL12V204S	2 1/4 in.		3.16	5.13	4.51	6.38	5.88	0.75	5/8	3.32	3.40	2.63	0.18	0.70	3.14	4.02	14	
QVFL12V055S	55 mm																	
QVFL14V060S	60 mm	22214	94.0	146.1	121.2	171.5	157.2	N/A	25.4	16	86.1	88.1	72.6	5.1	15.2	81.0	101.3	7.7
QVFL14V207S	2 7/16 in.		3.70	5.75	4.77	6.75	6.19	1.00	5/8	3.39	3.47	2.86	0.20	0.60	3.19	3.99	17	
QVFL14V208S	2 1/2 in.																	
QVFL14V065S	65 mm	22216	106.4	168.4	141.2	200.2	182.6	N/A	26.9	20	86.9	88.9	74.4	3.3	17.0	83.6	103.6	10.4
QVFL16V211S	2 11/16 in.		4.19	6.63	5.56	7.88	7.19	1.06	3/4	3.42	3.50	2.93	0.13	0.67	3.29	4.08	23	
QVFL16V070S	70 mm																	
QVFL16V215S	2 15/16 in.	22219	124.5	193.8	170.7	241.3	212.9	187.33	32.5	20	97.3	99.3	86.4	3.6	17.0	93.7	114.0	15.9
QVFL16V300S	3 in.		4.90	7.63	6.72	9.50	8.38	7.375	1.28	3/4	3.83	3.91	3.40	0.14	0.67	3.69	4.49	35
QVFL16V075S	75 mm																	
QVFL19V303S	3 3/16 in.	22222	139.7	229.6	193.0	273.1	241.3	215.90	38.1	24	116.8	118.9	104.6	11.9	9.9	104.9	126.7	24.9
QVFL19V304S	3 1/4 in.		5.50	9.04	7.60	10.75	9.50	8.500	1.50	1	4.60	4.68	4.12	0.47	0.39	4.13	4.99	55
QVFL19V080S	80 mm																	
QVFL19V085S	85 mm																	
QVFL19V307S	3 7/16 in.																	
QVFL19V308S	3 1/2 in.																	
QVFL19V090S	90 mm																	
QVFL22V311S	3 11/16 in.																	
QVFL22V312S	3 3/4 in.																	
QVFL22V100S	100 mm																	
QVFL22V315S	3 15/16 in.																	
QVFL22V400S	4 in.																	

⁽¹⁾ Bearing part numbers use QV to designate single-nut units (uses Rv and Sv dimensions) and QVV to designate double-nut units (uses Rvv and Svv dimensions).

⁽²⁾ Single-nut (QV) part number shown. Double-nut (QVV) version available upon request.

⁽³⁾ Pilot tolerance: +0/-0.08 mm (+0/-0.003 in.).

⁽⁴⁾ Add (p) to the end of the housing designation in the part number to order with pilot using G dimension.

⁽⁵⁾ Piloted flange blocks will be quoted (price and delivery) upon request. For optional spigot on flange side, insert the letter P as seen in the following example: QMFP**J***S.

QVFX AND QVFX 5000 SERIES SQUARE FLANGE BLOCKS – STRAIGHT BORE EQUIVALENT

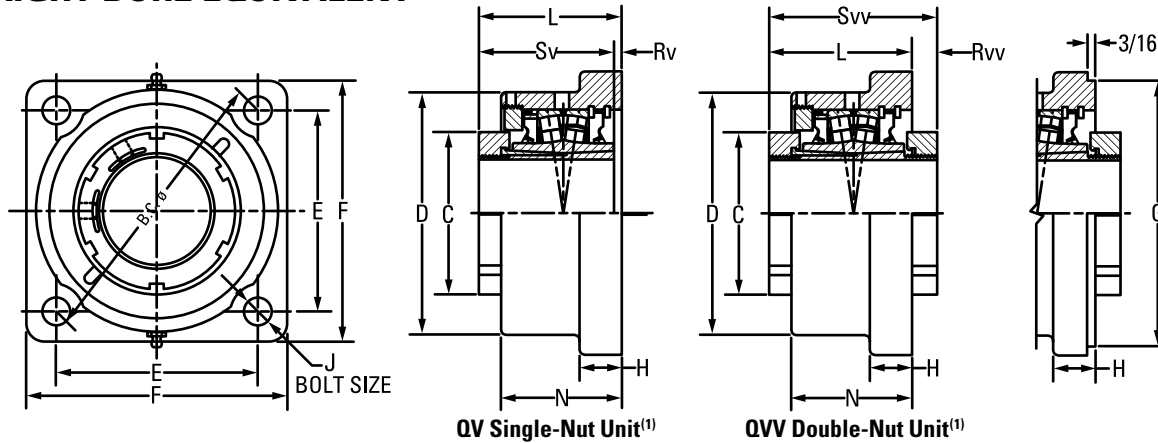

Bearing Part No. ⁽¹⁾⁽²⁾	Shaft Dia.	Bearing No.	C	D	E	B.C.	F	G ⁽³⁾⁽⁴⁾⁽⁵⁾	H	J	L _{FIX}	L _{EXP}	N	Rv ⁽¹⁾	Rvv	Sv ⁽¹⁾	Svv	Wt.
	mm in.		mm in.	mm in.	mm in.	mm in.	mm in.	mm in.	mm in.	mm in.	mm in.	mm in.	mm in.	mm in.	mm in.	mm in.	mm in.	kg lbs.
QVFX11V115S	1 15/16 in.	22211	75.9	120.7	103.6	146.1	134.9	111.13	22.4	12	84.1	86.1	65.0	4.1	18.3	79.8	102.1	5.0
QVFX11V200S	2 in.		2.99	4.75	4.08	5.75	5.31	4.375	0.88	1/2	3.31	3.39	2.56	0.16	0.72	3.14	4.02	11
QVFX11V050S	50 mm																	
QVFX12V203S	2 3/16 in.	22212	80.3	130.3	114.3	161.5	149.4	127.00	25.4	16	84.3	86.4	66.8	4.6	17.5	79.8	102.1	6.4
QVFX12V204S	2 1/4 in.		3.16	5.13	4.50	6.36	5.88	5.000	1.00	5/8	3.32	3.40	2.63	0.18	0.69	3.14	4.02	14
QVFX12V055S	55 mm																	
QVFX14V060S	60 mm	22214	94.0	146.1	127.8	180.8	157.2	138.13	25.4	16	85.1	87.4	72.4	4.1	16.0	81.0	101.3	7.7
QVFX14V207S	2 7/16 in.		3.70	5.75	5.03	7.12	6.19	5.438	1.00	5/8	3.35	3.44	2.85	0.16	0.63	3.19	3.99	17
QVFX14V208S	2 1/2 in.																	
QVFX14V065S	65 mm	22216	106.4	168.9	152.7	215.9	189.0	160.35	26.9	20	87.6	89.7	76.2	4.1	16.3	83.6	103.6	10.4
QVFX16V211S	2 11/16 in.		4.19	6.65	6.01	8.50	7.44	6.313	1.06	3/4	3.45	3.53	3.00	0.16	0.64	3.29	4.08	23
QVFX16V212S	2 3/4 in.																	
QVFX16V070S	70 mm	22219	124.5	193.8	170.7	241.3	212.6	187.33	33.3	20	98.3	100.6	84.1	4.8	15.7	93.7	114.0	15.9
QVFX16V215S	2 15/16 in.		4.90	7.63	6.72	9.50	8.37	7.375	1.31	3/4	3.87	3.96	3.31	0.19	0.62	3.69	4.49	35
QVFX16V300S	3 in.																	
QVFX16V075S	75 mm	22222	139.7	215.9	211.1	298.5	268.2	225.43	38.1	24	114.0	116.3	100.6	9.4	12.7	104.9	126.7	24.9
QVFX19V303S	3 3/16 in.		5.50	8.50	8.31	11.75	10.56	8.875	1.50	1	4.49	4.58	3.96	0.37	0.50	4.13	4.99	55
QVFX19V304S	3 1/4 in.																	
QVFX19V080S	80 mm	22226	174.8	256.5	163.6	327.2	384.3	263.53	38.1	24	140.5	142.7	106.9	7.4	37.8	147.8	178.3	49.0
QVFX19V085S	85 mm		6.88	10.10	6.44 ⁽⁶⁾	12.88 ⁽⁶⁾	15.13	10.375	1.50	1 ⁽⁶⁾	5.53	5.62	4.21	0.29	1.49	5.82	7.02	108
QVFX19V307S	3 7/16 in.																	
QVFX19V308S	3 1/2 in.	22228	189.7	284.2	177.8	355.6	419.1	284.18	38.1	24	166.1	168.1	138.4	18.3	12.2	147.8	178.3	52.2
QVFX19V090S	90 mm		7.47	11.19	7.00 ⁽⁶⁾	14.00 ⁽⁶⁾	16.50	11.188	1.50	1 1/8 ⁽⁶⁾	6.54	6.62	5.45	0.72	0.48	5.82	7.02	115
QVFX22V311S	3 11/16 in.																	
QVFX22V312S	3 3/4 in.																	
QVFX22V100S	100 mm																	
QVFX22V315S	3 15/16 in.																	
QVFX22V400S	4 in.																	
QVFX26V110S ⁽⁶⁾	110 mm																	
QVFX26V407S ⁽⁶⁾	4 7/16 in.																	
QVFX26V408S ⁽⁶⁾	4 1/2 in.																	
QVFX26V115S ⁽⁶⁾	115 mm																	
QVFX28V125S ⁽⁶⁾	125 mm																	
QVFX28V415S ⁽⁶⁾	4 15/16 in.																	
QVFX28V500S ⁽⁶⁾	5 in.																	
QVFX28V130S ⁽⁶⁾	130 mm																	

⁽¹⁾ Bearing part numbers use QV to designate single-nut units (uses Rv and Sv dimensions) and QVV to designate double-nut units (uses Rvv and Sv dimensions).

⁽²⁾ Single-nut (QV) part number shown. Double-nut (QVV) version available upon request.

⁽³⁾ Pilot tolerance: +0/-0.05 mm (+0/-0.002 in.).

⁽⁴⁾ Add (p) to the end of the housing designation in the part number to order with pilot using G dimension.

⁽⁵⁾ Piloted flange blocks will be quoted (price and delivery) upon request. For optional spigot on flange side, insert the letter P as seen in the following example: QMFP**J***S.

⁽⁶⁾ Six-bolt round housing.

QVFK AND QVVK 9000 SERIES SQUARE FLANGE BLOCKS – TAPERED BORE EQUIVALENT

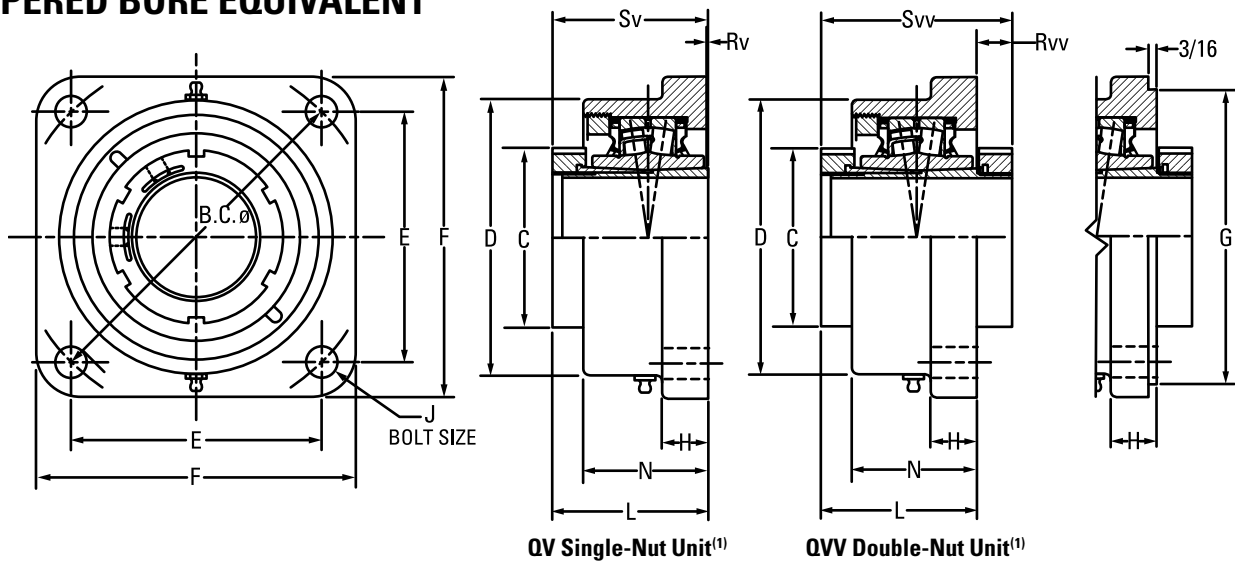

Bearing Part No. ⁽¹⁾⁽²⁾	Shaft Dia.	Bearing No.	C	D	E	B.C.	F	G ⁽³⁾⁽⁴⁾⁽⁵⁾	H	J	L _{FIX}	L _{EXP}	N	Rv ⁽¹⁾	Rvv	Sv ⁽¹⁾	Svv	Wt.
	mm in.		mm in.	mm in.	mm in.	mm in.	mm in.	mm in.	mm in.	mm in.	mm in.	mm in.	mm in.	mm in.	mm in.	mm in.	mm in.	kg lbs.
QVFK11V115S	1 15/16 in.	22211	75.9	130.3	114.3	161.5	149.4	127.00	25.4	16	87.1	88.4	66.8	7.4	15.0	79.8	102.1	5.0
QVFK11V200S	2 in.		2.99	5.13	4.50	6.36	5.88	5.000	1.00	5/8	3.43	3.48	2.63	0.29	0.59	3.14	4.02	11
QVFK11V050S	50 mm																	
QVFK13V203S	2 3/16 in.	22213	80.3	146.1	127.8	180.8	157.2	138.13	25.4	16	92.2	94.2	72.4	6.9	15.5	85.3	107.7	6.4
QVFK13V204S	2 1/4 in.		3.16	5.75	5.03	7.12	6.19	5.438	1.00	5/8	3.63	3.71	2.85	0.27	0.61	3.36	4.24	14
QVFK13V055S	55 mm																	
QVFK15V207S	2 7/16 in.	22215	94.0	168.9	152.7	215.9	189.0	160.35	26.9	20	92.5	94.5	76.2	9.9	11.4	82.6	103.9	7.7
QVFK15V208S	2 1/2 in.		3.70	6.65	6.01	8.50	7.44	6.313	1.06	3/4	3.64	3.72	3.00	0.39	0.45	3.25	4.09	17
QVFK15V065S	65 mm																	
QVFK17V211S	2 11/16 in.	22217	106.4	193.8	170.7	241.3	212.9	187.33	33.3	20	92.5	101.1	84.1	14.5	7.1	84.6	106.2	10.4
QVFK17V212S	2 3/4 in.		4.19	7.63	6.72	9.50	8.38	7.375	1.31	3/4	3.64	3.98	3.31	0.57	0.28	3.33	4.18	23
QVFK17V070S	70 mm																	
QVFK17V215S	2 15/16 in.	22220	124.5	215.9	211.1	298.5	268.2	225.43	38.1	24	113.3	115.3	103.1	18.0	4.1	95.3	117.3	15.9
QVFK17V300S	3 in.		4.90	8.50	8.31	11.75	10.56	8.875	1.50	7/8	4.46	4.54	4.06	0.71	0.16	3.75	4.62	35
QVFK17V075S	75 mm																	
QVFK20V303S	3 3/16 in.	22222	139.7	256.5	168.7	327.2	384.3	263.53	31.8	24	117.3	119.4	106.9	12.4	9.7	104.9	126.7	24.9
QVFK20V304S	3 1/4 in.		5.50	10.10	6.64 ⁽⁶⁾	12.88 ⁽⁶⁾	15.13	10.375	1.25	1 ⁽⁶⁾	4.62	4.70	4.21	0.49	0.38	4.13	4.99	55
QVFK20V080S	80 mm																	
QVFK20V085S	85 mm	22226	174.8	284.2	177.8	355.6	419.1	284.18	38.1	28.6	164.6	166.6	135.1	11.7	13.7	147.8	178.3	49.0
QVFK20V307S	3 7/16 in.		6.88	11.19	7.00 ⁽⁶⁾	14.00 ⁽⁶⁾	16.50	11.188	1.50	1 1/8 ⁽⁶⁾	6.48	6.56	5.32	0.46	0.54	5.82	7.02	108
QVFK20V308S	3 1/2 in.																	
QVFK20V090S	90 mm																	
QVFK22V311S ⁽⁶⁾	3 11/16 in.	22222	139.7	256.5	168.7	327.2	384.3	263.53	31.8	24	117.3	119.4	106.9	12.4	9.7	104.9	126.7	24.9
QVFK22V312S ⁽⁶⁾	3 3/4 in.		5.50	10.10	6.64 ⁽⁶⁾	12.88 ⁽⁶⁾	15.13	10.375	1.25	1 ⁽⁶⁾	4.62	4.70	4.21	0.49	0.38	4.13	4.99	55
QVFK22V100S ⁽⁶⁾	100 mm																	
QVFK22V315S ⁽⁶⁾	3 15/16 in.	22226	174.8	284.2	177.8	355.6	419.1	284.18	38.1	28.6	164.6	166.6	135.1	11.7	13.7	147.8	178.3	49.0
QVFK22V400S ⁽⁶⁾	4 in.		6.88	11.19	7.00 ⁽⁶⁾	14.00 ⁽⁶⁾	16.50	11.188	1.50	1 1/8 ⁽⁶⁾	6.48	6.56	5.32	0.46	0.54	5.82	7.02	108
QVFK26V110S ⁽⁶⁾	110 mm																	
QVFK26V407S ⁽⁶⁾	4 7/16 in.	22226	174.8	284.2	177.8	355.6	419.1	284.18	38.1	28.6	164.6	166.6	135.1	11.7	13.7	147.8	178.3	49.0
QVFK26V408S ⁽⁶⁾	4 1/2 in.		6.88	11.19	7.00 ⁽⁶⁾	14.00 ⁽⁶⁾	16.50	11.188	1.50	1 1/8 ⁽⁶⁾	6.48	6.56	5.32	0.46	0.54	5.82	7.02	108
QVFK26V115S ⁽⁶⁾	115 mm																	

⁽¹⁾ Bearing part numbers use QV to designate single-nut units (uses Rv and Sv dimensions) and QVV to designate double-nut units (uses Rvv and Sv dimensions).

⁽²⁾ Single-nut (QV) part number shown. Double-nut (QVV) version available upon request.

⁽³⁾ Pilot tolerance: +0/-0.05 mm (+0/-0.002 in.).

⁽⁴⁾ Add (p) to the end of the housing designation in the part number to order with pilot using G dimension.

⁽⁵⁾ Piloted flange blocks will be quoted (price and delivery) upon request. For optional spigot on flange side, insert the letter P as seen in the following example: QMFP**J***S.

⁽⁶⁾ Six-bolt round housing.

QVfy AND QVfy ROUND FLANGE BLOCKS – STRAIGHT BORE EQUIVALENT

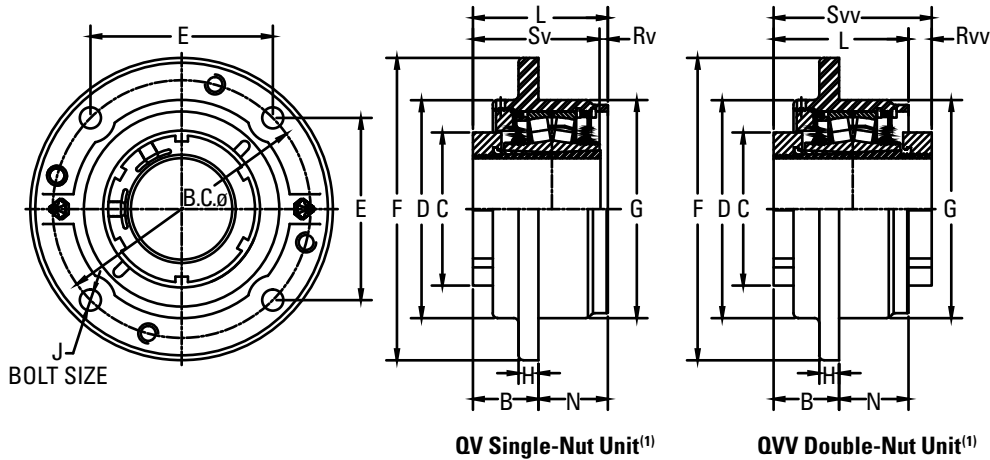

Bearing Part No. ⁽¹⁾⁽²⁾	Shaft Dia.	Bearing No.	C	D	E	B.C.	F	G ⁽³⁾⁽⁴⁾⁽⁵⁾	H	J	L _{FIX}	L _{EXP}	N	Rv ⁽¹⁾	Rvv	Sv ⁽¹⁾	Svv	Wt.	
	mm in.		mm in.	mm in.	mm in.	mm in.	mm in.	mm in.	mm in.	mm in.	mm in.	mm in.	mm in.	mm in.	mm in.	mm in.	mm in.	kg lbs.	
QVfy11V115S	1 15/16 in.	22211	75.9	115.3	103.4	146.1	177.8	111.13	19.1	12	78.5	80.5	58.4	1.5	23.9	79.8	102.1	5.4	
QVfy11V200S	2 in.		2.99	4.54	4.07	5.75	7.00	4.375	0.75	1/2	3.09	3.17	2.30	0.06	0.94	3.14	4.02	12	
QVfy11V050S	50 mm																		
QVfy12V203S	2 3/16 in.	22212	80.3	130.3	114.6	162.1	196.9	127.00	19.1	16	80.0	82.0	62.0	0.3	22.1	79.8	102.1	6.8	
QVfy12V204S	2 1/4 in.		3.16	5.13	4.51	6.38	7.75	5.000	0.75	5/8	3.15	3.23	2.44	0.01	0.87	3.14	4.02	15	
QVfy12V055S	55 mm																		
QVfy14V060S	60 mm	22214																	
QVfy14V207S	2 7/16 in.		94.0	146.1	121.2	171.5	206.5	138.13	23.9	16	84.8	86.9	72.4	3.8	16.5	81.0	101.3	8.6	
QVfy14V208S	2 1/2 in.		3.70	5.75	4.77	6.75	8.13	5.438	0.94	5/8	3.34	3.42	2.85	0.15	0.65	3.19	3.99	19	
QVfy14V065S	65 mm	22216																	
QVfy16V211S	2 11/16 in.																		
QVfy16V212S	2 3/4 in.		106.4	168.4	141.2	200.2	241.3	160.35	23.9	20	88.4	90.4	76.2	4.8	15.2	83.6	103.6	12.7	
QVfy16V070S	70 mm	22219	4.19	6.63	5.56	7.88	9.50	6.313	0.94	3/4	3.48	3.56	3.00	0.19	0.60	3.29	4.08	28	
QVfy16V215S	2 15/16 in.																		
QVfy16V300S	3 in.																		
QVfy16V075S	75 mm	22222																	
QVfy19V303S	3 3/16 in.																		
QVfy19V304S	3 1/4 in.		124.5	193.8	170.7	241.3	282.7	187.33	28.7	24	98.3	116.1	85.3	4.8	15.7	93.7	114.0	19.1	
QVfy19V080S	80 mm	22226	4.90	7.63	6.72	9.50	11.13	7.375	1.13	7/8	3.87	4.57	3.36	0.19	0.62	3.69	4.49	42	
QVfy19V085S	85 mm																		
QVfy19V307S	3 7/16 in.																		
QVfy19V308S	3 1/2 in.	22228																	
QVfy19V090S	90 mm																		
QVfy22V311S	3 11/16 in.		139.7	222.5	193.0	273.1	320.8	N/A	28.7	24	115.3	117.3	103.1	10.4	11.4	104.9	126.7	29.9	
QVfy22V312S	3 3/4 in.	22228	5.50	8.76	7.60	10.75	12.63	N/A	1.13	1	4.54	4.62	4.06	0.41	0.45	4.13	4.99	66	
QVfy22V100S	100 mm																		
QVfy22V315S	3 15/16 in.																		
QVfy22V400S	4 in.	22226																	
QVfy26V110S ⁽⁶⁾	110 mm																		
QVfy26V407S ⁽⁶⁾	4 7/16 in.		174.8	230.1	163.6	327.2	384.3	N/A	38.1	24	140.5	142.7	106.9	7.4	37.8	147.8	178.3	49.0	
QVfy26V408S ⁽⁶⁾	4 1/2 in.	22228	6.88	9.06	6.44 ⁽⁶⁾	12.88 ⁽⁶⁾	15.13	N/A	1.50	1 ⁽⁶⁾	5.53	5.62	4.21	0.29	1.49	5.82	7.02	108	
QVfy26V115S ⁽⁶⁾	115 mm																		
QVfy26V125S ⁽⁶⁾	125 mm																		
QVfy28V415S ⁽⁶⁾	4 15/16 in.	22228	190.0	284.2	177.8	355.6	419.1	N/A	38.1	24	166.1	168.1	138.4	18.3	12.2	147.8	178.3	52.2	
QVfy28V500S ⁽⁶⁾	5 in.		7.48	11.19	7.00 ⁽⁶⁾	14.00 ⁽⁶⁾	16.50	N/A	1.50	1 1/8 ⁽⁶⁾	6.54	6.62	5.45	0.72	0.48	5.82	7.02	115	
QVfy28V130S ⁽⁶⁾	130 mm																		

⁽¹⁾Bearing part numbers use QV to designate single-nut units (uses Rv and Sv dimensions) and QVV to designate double-nut units (uses Rvv and Svv dimensions).

⁽²⁾Single-nut (QV) part number shown. Double-nut (QVV) version available upon request.

⁽³⁾Pilot tolerance: +0/-0.05 mm (+0/-0.002 in.).

⁽⁴⁾Add (p) to the end of the housing designation in the part number to order with pilot using G dimension.

⁽⁵⁾Piloted flange blocks will be quoted (price and delivery) upon request. For optional spigot on flange side, insert the letter P as seen in the following example: QMFP**J***S.

⁽⁶⁾Six-bolt round housing.

QVC AND QVVC PILOTED FLANGE CARTRIDGES – STRAIGHT BORE EQUIVALENT

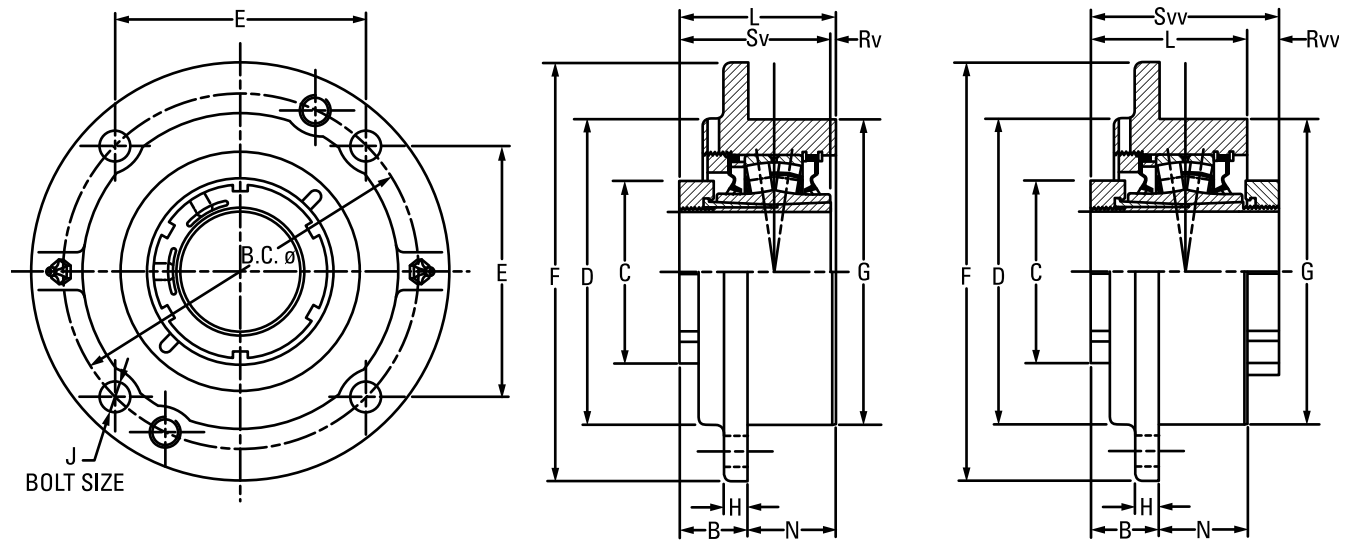

QV Single-Nut Unit⁽¹⁾

QVV Double-Nut Unit⁽¹⁾

Bearing Part No. ⁽¹⁾⁽²⁾	Shaft Dia.	Bearing No.	B _{FIX}	B _{EXP}	C	D	B.C.	E	F	G ⁽³⁾	H	J	L	N	Rv ⁽¹⁾	Rvv	Sv ⁽¹⁾	Svv	Wt.	
	mm in.		mm in.	mm in.	mm in.	mm in.	mm in.	mm in.	mm in.	mm in.	mm in.	mm in.	mm in.	mm in.	mm in.	mm in.	mm in.	mm in.	mm in.	kg lbs.
QVC11V115S	1 15/16 in.	22211	53.8	55.9	75.9	113.5	136.7	96.5	162.1	114.3	16.0	10	80.8	26.9	0.8	21.6	79.8	102.1	4.5	
QVC11V200S	2 in.		2.12	2.20	2.99	4.47	5.38	3.80	6.38	4.500	0.63	7/16	3.18	1.06	0.03	0.85	3.14	4.02	10	
QVC11V050S	50 mm																			
QVC12V203S	2 3/16 in.	22212	51.3	53.3	80.3	127.0	152.4	107.7	185.4	127.0	14.7	12	80.0	28.7	0.3	22.1	79.8	102.1	5.9	
QVC12V204S	2 1/4 in.		2.02	2.10	3.16	5.00	6.00	4.24	7.30	5.000	0.58	1/2	3.15	1.13	0.01	0.87	3.14	4.02	13	
QVC12V055S	55 mm																			
QVC14V060S	60 mm	22214	56.1	58.2	94.0	139.7	165.1	116.8	193.8	139.7	17.5	12	84.6	28.7	3.8	16.5	81.0	101.3	7.3	
QVC14V207S	2 7/16 in.		2.21	2.29	3.70	5.50	6.50	4.60	7.63	5.500	0.69	1/2	3.33	1.13	0.15	0.65	3.19	3.99	16	
QVC14V208S	2 1/2 in.																			
QVC14V065S	65 mm	22216	52.8	54.9	106.4	162.1	190.5	134.6	222.3	161.9	20.6	16	84.6	31.8	1.0	19.3	83.6	103.6	10.0	
QVC16V211S	2 11/16 in.		2.08	2.16	4.19	6.38	7.50	5.30	8.75	6.375	0.81	5/8	3.33	1.25	0.04	0.76	3.29	4.08	22	
QVC16V212S	2 3/4 in.																			
QVC16V070S	70 mm	22219	62.5	64.5	124.5	185.2	219.2	154.9	262.6	187.3	25.4	20	95.8	33.3	2.0	18.5	93.7	114.0	14.5	
QVC16V215S	2 15/16 in.		2.46	2.54	4.90	7.29	8.63	6.10	10.34	7.375	1.00	3/4	3.77	1.31	0.08	0.73	3.69	4.49	32	
QVC16V300S	3 in.																			
QVC16V075S	75 mm	22222	60.2	62.2	139.7	222.5	238.3	168.4	276.4	206.4	25.4	20	115.3	54.1	10.4	11.7	104.9	126.7	19.5	
QVC19V303S	3 3/16 in.		2.37	2.45	5.50	8.76	9.38	6.63	10.88	8.125	1.00	3/4	4.54	2.13	0.41	0.46	4.13	4.99	43	
QVC19V304S	3 1/4 in.																			
QVC19V080S	80 mm	22226	86.4	88.4	174.8	260.4	298.5	149.4	342.9	260.4	25.4	20	134.6	48.3	13.2	43.7	147.8	178.3	32.7	
QVC19V085S	85 mm		3.40	3.48	6.88	10.25	11.75 ⁽⁴⁾	5.88 ⁽⁴⁾	13.50	10.250	1.00	3/4 ⁽⁴⁾	5.30	1.90	0.52	1.72	5.82	7.02	72	
QVC19V307S	3 7/16 in.																			
QVC19V308S	3 1/2 in.																			
QVC19V090S	90 mm																			
QVC22V311S	3 11/16 in.																			
QVC22V312S	3 3/4 in.																			
QVC22V100S	100 mm																			
QVC22V315S	3 15/16 in.																			
QVC22V400S	4 in.																			
QVC26V110S ⁽⁴⁾	110 mm																			
QVC26V407S ⁽⁴⁾	4 7/16 in.																			
QVC26V408S ⁽⁴⁾	4 1/2 in.																			
QVC26V115S ⁽⁴⁾	115 mm																			

⁽¹⁾ Bearing part numbers use QV to designate single-nut units (uses Rv and Sv dimensions) and QVV to designate double-nut units (uses Rvv and Svv dimensions).

⁽²⁾ Single-nut (QV) part number shown. Double-nut (QVV) version available upon request.

⁽³⁾ Pilot tolerance: +0/-0.05 mm (+0/-0.002 in.).

⁽⁴⁾ Six-bolt round housing.

QVCW AND QVVCW PILOTED FLANGE CARTRIDGES – STRAIGHT BORE EQUIVALENT

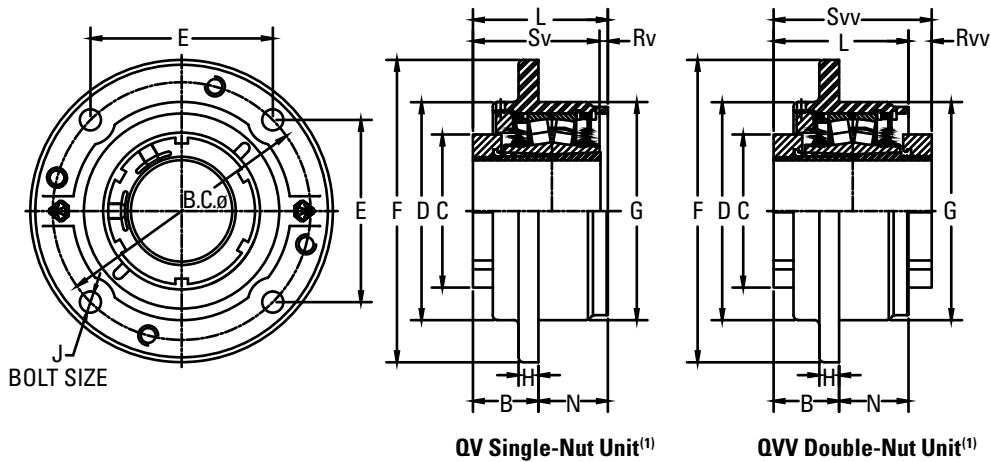

Bearing Part No. ⁽¹⁾⁽²⁾	Shaft Dia.	Bearing No.	B _{FIX}	B _{EXP}	C	D	B.C.	E	F	G ⁽³⁾	H	J	L	N	Rv ⁽¹⁾	Rvv	Sv ⁽¹⁾	Svv	Wt.	
	mm in.		mm in.	mm in.	mm in.	mm in.	mm in.	mm in.	mm in.	mm in.	mm in.	mm in.	mm in.	mm in.	mm in.	mm in.	mm in.	mm in.	mm in.	kg lbs.
QVCW11V115S	1 15/16 in.	22211	42.2	44.2	75.9	113.5	136.7	96.5	162.1	114.3	9.7	10	80.3	38.1	0.8	21.8	79.8	102.1	4.5	
QVCW11V200S	2 in.		1.66	1.74	2.99	4.47	5.38	3.80	6.38	4.500	0.38	7/16	3.16	1.50	0.03	0.86	3.14	4.02	10	
QVCW11V050S	50 mm																			
QVCW12V203S	2 3/16 in.	22212	43.2	45.5	80.3	127.0	152.4	107.7	181.1	127.0	14.2	12	84.6	41.4	4.8	17.5	79.8	102.1	5.9	
QVCW12V204S	2 1/4 in.		1.70	1.79	3.16	5.00	6.00	4.24	7.13	5.000	0.56	1/2	3.33	1.63	0.19	0.69	3.14	4.02	13	
QVCW12V055S	55 mm																			
QVCW14V060S	60 mm	22214	41.9	43.9	94.0	139.7	165.1	116.8	193.8	139.7	12.7	12	86.4	42.9	5.3	15.0	81.0	101.3	7.3	
QVCW14V207S	2 7/16 in.		1.65	1.73	3.70	5.50	6.50	4.60	7.63	5.500	0.50	1/2	3.40	1.69	0.21	0.59	3.19	3.99	16	
QVCW14V208S	2 1/2 in.																			
QVCW14V065S	65 mm	22216	37.6	39.6	106.4	162.1	190.5	134.6	222.3	161.9	12.7	16	85.1	47.8	1.8	18.5	83.6	103.6	10.0	
QVCW16V211S	2 11/16 in.		1.48	1.56	4.19	6.38	7.50	5.30	8.75	6.375	0.50	5/8	3.35	1.88	0.07	0.73	3.29	4.08	22	
QVCW16V212S	2 3/4 in.																			
QVCW16V070S	70 mm	22219	49.8	51.8	124.5	187.5	219.2	154.9	260.4	187.3	22.4	20	97.5	47.8	3.8	16.8	93.7	114.0	14.5	
QVCW16V215S	2 15/16 in.		1.96	2.04	4.90	7.38	8.63	6.10	10.25	7.375	0.88	3/4	3.84	1.88	0.15	0.66	3.69	4.49	32	
QVCW16V300S	3 in.																			
QVCW16V075S	75 mm	22222	51.6	53.6	139.7	222.5	238.3	168.4	276.4	206.4	25.4	20	109.7	57.2	4.8	17.3	104.9	126.7	19.5	
QVCW19V303S	3 3/16 in.		2.03	2.11	5.50	8.76	9.38	6.63	10.88	8.125	1.00	3/4	4.32	2.25	0.19	0.68	4.13	4.99	43	
QVCW19V304S	3 1/4 in.																			
QVCW19V080S	80 mm	22226	72.4	74.4	174.8	260.4	298.5	149.4	342.9	260.4	25.4	20	140.5	68.3	7.4	37.8	147.8	178.3	32.7	
QVCW19V085S	85 mm		1.96	2.04	4.90	7.38	8.63	6.10	10.25	7.375	0.88	3/4	3.84	1.88	0.15	0.66	3.69	4.49	32	
QVCW19V307S	3 7/16 in.																			
QVCW19V308S	3 1/2 in.	22228	66.5	68.6	190.0	266.7	323.9	162.1	374.7	279.4	26.2	24	144.5	78.0	3.3	33.8	147.8	178.3	46.3	
QVCW19V090S	90 mm		2.62	2.70	7.48	10.50	12.75	6.38	14.75	11.000	1.03	7/8	5.69	3.07	0.13	1.33	5.82	7.02	102	
QVCW22V311S	3 11/16 in.																			
QVCW22V312S	3 3/4 in.	22226	72.4	74.4	174.8	260.4	298.5	149.4	342.9	260.4	25.4	20	140.5	68.3	7.4	37.8	147.8	178.3	32.7	
QVCW22V100S	100 mm		2.85	2.93	6.88	10.25	11.75	5.88	13.50	10.250	1.00	3/4	5.53	2.69	0.29	1.49	5.82	7.02	72	
QVCW22V315S	3 15/16 in.																			
QVCW22V400S	4 in.	22228	66.5	68.6	190.0	266.7	323.9	162.1	374.7	279.4	26.2	24	144.5	78.0	3.3	33.8	147.8	178.3	46.3	
QVCW26V110S ⁽⁴⁾	110 mm		2.62	2.70	7.48	10.50	12.75	6.38	14.75	11.000	1.03	7/8	5.69	3.07	0.13	1.33	5.82	7.02	102	
QVCW26V407S ⁽⁴⁾	4 7/16 in.																			
QVCW26V408S ⁽⁴⁾	4 1/2 in.	22228	66.5	68.6	190.0	266.7	323.9	162.1	374.7	279.4	26.2	24	144.5	78.0	3.3	33.8	147.8	178.3	46.3	
QVCW26V115S ⁽⁴⁾	115 mm		2.62	2.70	7.48	10.50	12.75	6.38	14.75	11.000	1.03	7/8	5.69	3.07	0.13	1.33	5.82	7.02	102	
QVCW28V125S ⁽⁴⁾	125 mm																			
QVCW28V415S ⁽⁴⁾	4 15/16 in.	22228	66.5	68.6	190.0	266.7	323.9	162.1	374.7	279.4	26.2	24	144.5	78.0	3.3	33.8	147.8	178.3	46.3	
QVCW28V500S ⁽⁴⁾	5 in.		2.62	2.70	7.48	10.50	12.75	6.38	14.75	11.000	1.03	7/8	5.69	3.07	0.13	1.33	5.82	7.02	102	
QVCW28V130S ⁽⁴⁾	130 mm																			

⁽¹⁾ Bearing part numbers use QV to designate single-nut units (uses Rv and Sv dimensions) and QVV to designate double-nut units (uses Rvv and Sv dimensions).
⁽²⁾ Single-nut (QV) part number shown. Double-nut (QVV) version available upon request.
⁽³⁾ Pilot tolerance: +0/-0.05 mm (+0/-0.002 in.).
⁽⁴⁾ Six-bolt round housing.

QVMC AND QVVMC CARTRIDGE BLOCKS – TAPERED BORE EQUIVALENT

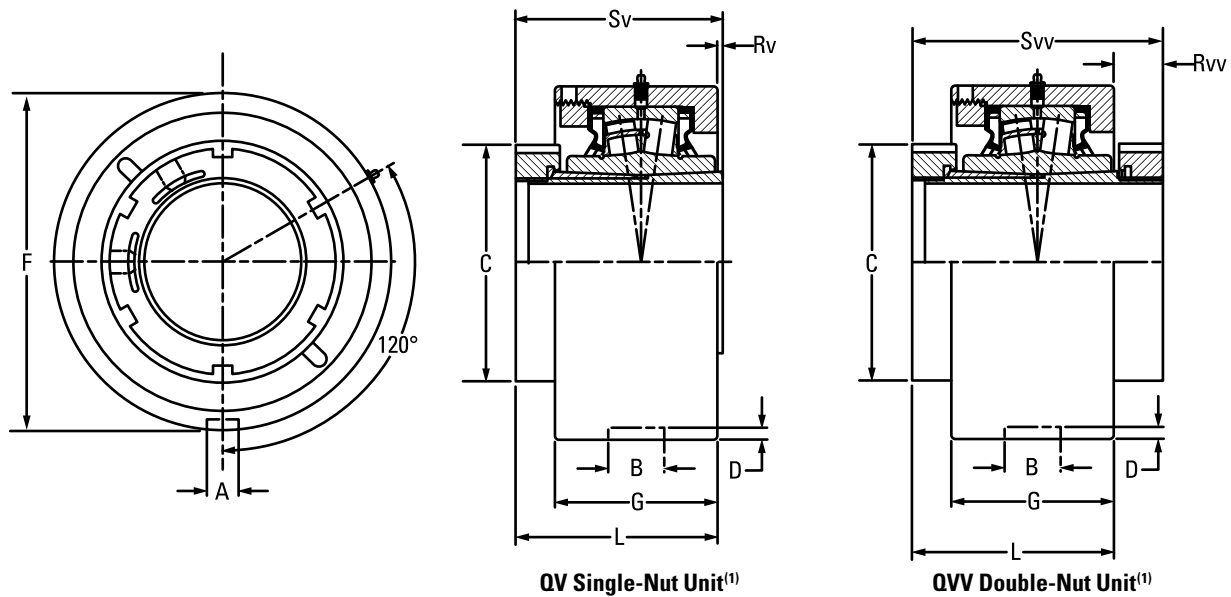

Bearing Part No. ⁽¹⁾⁽²⁾	Shaft Dia.	Bearing No.	A	B	C	D	F	G	L FIX	L EXP	Rv ⁽¹⁾	Rvv	Sv ⁽¹⁾	Svv	Wt.	
	mm in.		mm in.	mm in.	mm in.	mm in.	mm in.	mm in.	mm in.	mm in.	mm in.	mm in.	mm in.	mm in.	kg lbs.	
QVMC11V115S	1 15/16 in.	22211	13.5 0.530	23.0 0.906	75.9 2.99	4.8 0.188	115.09	55.4 2.180	79.0 3.11	81.0 3.19	0.8 0.03	23.1 0.91	79.8 3.14	102.1 4.02	4.5 10	
QVMC11V200S	2 in.						4.531									
QVMC11V050S	50 mm						(+0/-0.002)									
QVMC13V203S	2 3/16 in.	22213	13.5 0.530	23.0 0.906	80.3 3.16	4.8 0.188	127.00	67.1 2.640	85.9 3.38	87.9 3.46	0.5 0.02	21.8 0.86	85.3 3.36	107.7 4.24	5.4 12	
QVMC13V204S	2 1/4 in.						5.000									
QVMC13V055S	55 mm						(+0/-0.002)									
QVMC15V060S	60 mm	22215	15.1 0.594	26.2 1.032	94.0 3.70	6.4 0.250	149.23	70.6 2.780	87.4 3.44	89.4 3.52	5.1 0.20	16.5 0.65	82.6 3.25	103.9 4.09	8.2 18	
QVMC15V207S	2 7/16 in.						4.531									
QVMC15V208S	2 1/2 in.						5.875									
QVMC15V065S	65 mm						(+0/-0.002)									
QVMC17V211S	2 11/16 in.	22217	15.1 0.594	27.5 1.083	106.4 4.19	7.1 0.281	171.45	74.9 2.950	91.2 3.59	93.2 3.67	6.4 0.25	15.0 0.59	84.6 3.33	106.2 4.18	11.8 26	
QVMC17V212S	2 3/4 in.						6.75									
QVMC17V070S	70 mm						(+0/-0.002)									
QVMC17V215S	2 15/16 in.															
QVMC17V300S	3 in.															
QVMC17V075S	75 mm															
QVMC20V303S	3 3/16 in.	22220	19.8 0.781	32.5 1.281	124.5 4.90	8.0 0.313	206.38	85.6 3.370	102.1 4.02	104.1 4.10	6.9 0.27	15.2 0.60	95.3 3.75	117.3 4.62	14.5 32	
QVMC20V304S	3 1/4 in.						8.125									
QVMC20V080S	80 mm						(+0/-0.002)									
QVMC20V085S	85 mm															
QVMC20V307S	3 7/16 in.															
QVMC20V308S	3 1/2 in.															
QVMC20V090S	90 mm															
QVMC22V311S	3 11/16 in.	22222	19.8 0.781	32.5 1.281	139.7 5.50	8.0 0.313	222.25	97.8 3.850	113.0 4.45	115.1 4.53	8.1 0.32	14.0 0.55	104.9 4.13	126.7 4.99	18.1 40	
QVMC22V312S	3 3/4 in.						8.75									
QVMC22V100S	100 mm						(+0/-0.003)									
QVMC22V315S	3 15/16 in.															
QVMC22V400S	4 in.															
QVMC26V110S	110 mm	22226	19.8 0.780	38.1 1.500	174.8 6.88	8.0 0.313	265.10	104.4 4.110	141.5 5.57	143.5 5.65	6.4 0.25	36.8 1.45	147.8 5.82	178.3 7.02	23.6 52	
QVMC26V407S	4 7/16 in.						10.437									
QVMC26V408S	4 1/2 in.						(+0/-0.003)									
QVMC26V115S	115 mm															

⁽¹⁾Bearing part numbers use QV to designate single-nut units (uses Rv and Sv dimensions) and QVV to designate double-nut units (uses Rvv and Svv dimensions).

⁽²⁾Single-nut (QV) part number shown. Double-nut (QVV) version available upon request.

QVVTU TAKE-UP BLOCKS – STRAIGHT BORE EQUIVALENT

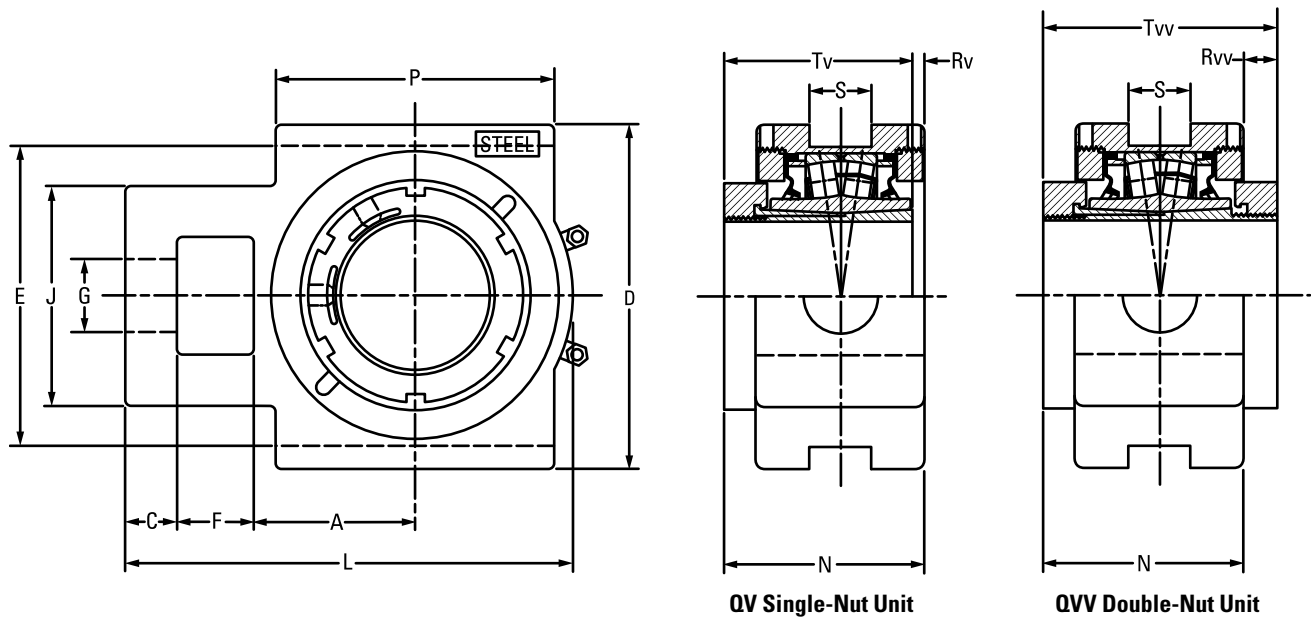

Bearing Part No. ⁽¹⁾	Shaft Dia.	Bearing No.	A	C	D	E	F	G	J	L	N	P	S	Rv ⁽¹⁾	Rvv	Tv ⁽¹⁾	Tvv	Wt.	
	mm in.		mm in.	mm in.	mm in.	mm in.	mm in.	mm in.	mm in.	mm in.	mm in.	mm in.	mm in.	mm in.	mm in.	mm in.	mm in.	kg lbs.	
QVVTU14V060S	60 mm	22214	69.9	22.4	149.4	130.3	33.3	33.3	95.3	193.8	88.4	120.7	26.9	3.3	15.5	85.1	103.9	7.7	
QVVTU14V207S	2 7/16 in.		2.75	0.88	5.88	5.13	1.31	1.31	3.75	7.63	3.48	4.75	1.06	0.13	0.61	3.35	4.09	17	
QVVTU14V208S	2 1/2 in.																		
QVVTU14V065S	65 mm																		
QVVTU16V211S	2 11/16 in.	22216	76.2	25.4	171.5	150.9	39.6	39.6	108.0	219.7	90.2	120.7	46.0	2.3	16.3	87.6	106.2	15.9	
QVVTU16V212S	2 3/4 in.		3.00	1.00	6.75	5.94	1.56	1.56	4.25	8.65	3.55	4.75	1.81	0.09	0.64	3.45	4.18	35	
QVVTU16V070S	70 mm																		
QVVTU16V215S	2 15/16 in.																		
QVVTU16V300S	3 in.																		
QVVTU16V075S	75 mm	22219	92.2	25.4	193.8	173.0	46.0	47.8	124.0	257.0	99.6	158.8	46.0	0.5	18.0	99.1	117.6	20.0	
QVVTU19V303S	3 3/16 in.		3.63	1.00	7.63	6.81	1.81	1.88	4.88	10.12	3.92	6.25	1.81	0.02	0.71	3.90	4.63	44	
QVVTU19V304S	3 1/4 in.																		
QVVTU19V080S	80 mm																		
QVVTU19V085S	85 mm																		
QVVTU19V307S	3 7/16 in.																		
QVVTU19V308S	3 1/2 in.																		
QVVTU19V090S	90 mm	22222	104.9	28.7	239.8	219.2	54.1	52.3	143.0	296.9	111.3	177.8	52.3	1.5	18.8	110.0	130.3	26.3	
QVVTU22V311S	3 11/16 in.		4.13	1.13	9.44	8.63	2.13	2.06	5.63	11.69	4.21	7.00	2.06	0.32	0.55	4.13	4.99	58	
QVVTU22V312S	3 3/4 in.																		
QVVTU22V100S	100 mm																		
QVVTU22V315S	3 15/16 in.																		
QVVTU22V400S	4 in.																		

⁽¹⁾Double-nut (QVV) part number shown. Single-nut (QV) version available upon request.

CL SERIES

Available in both single-collar (QA) and double-collar (QAA) versions, the CL bearing series features a concentric locking collar with two set screws at 60 degrees to provide maximum positive locking power with minimal run out.



Fig. 45. CL series single-collar (QA) insert available up to 100 mm (4 in.).



Fig. 46. CL series double-collar (QAA) insert for size ranges 50 mm – 130 mm (1 15/16 in. – 5 in.).

YOU HAVE CHOICES

For the CL series, you can select either single-collar or double-collar versions and choose from many seal configurations and housing styles, which are shown on page 65.

HOUSINGS

- Two-bolt pillow blocks.
- Four-bolt pillow blocks.
- Flange blocks.
- Piloted flange cartridges.
- Take-up blocks.
- Cartridge blocks.
- Hanger blocks.

SEALS

- Labyrinth: DuPont Teflon (T).
- Triple-lip: nitrile rubber (M), urethane (O) and DuPont Viton (N).
- Double-lip: nitrile rubber (B) and DuPont Viton (C).
- Steel and urethane closed-end covers (CS).
- Steel and urethane open-end covers (CJ) with:
 - DuPont Teflon (T).
 - Triple-lip seal (DR).
 - V-ring seal (VR).
- Piloted flange cartridge backing plates (HSY) with:
 - Triple-lip seal (DR).
- Flange block backing plates (UFP).
 - V-ring (VR).

CL SERIES

	Housing Type	Primary Seals						Secondary Seals and Covers					
		M	N	O	B	C	T	Open-End Cover			Closed-End Cover	HSY Flange Cartridge Backing Plate	UFP Backing Plate
								DR	VR	T		DR	
V-Lock (Timken Exclusive Double Taper Lock)	Pillow Block	•	•	•	•	•	•	•	•	•	•		
	Flange Block	•	•	•	•	•	•	•	•	•	•		
	Piloted Flange Cartridge	•	•	•	•	•	•	•	•	•	•		
	Take-Up Block	•	•	•	•	•	•	•	•	•	•		
	Cartridge Block	•	•	•	•	•	•	•	•	•	•		
CL Series (Set Screw Lock)	Pillow Block	•	•	•	•	•	•	•	•	•	•		
	Flange Block	•	•	•	•	•	•	•	•	•	•		•
	Piloted Flange Cartridge	•	•	•	•	•	•	•	•	•	•	•	
	Take-Up Block	•	•	•	•	•	•	•	•	•	•		
	Cartridge Block	•	•	•	•	•	•	•	•	•	•		
	Hanger Block	•	•	•	•	•	•	•	•	•	•		
EC Series (Eccentric Lock)	Pillow Block	•	•	•	•	•	•	•	•	•	•		
	Flange Block	•	•	•	•	•	•	•	•	•	•		•
	Piloted Flange Cartridge	•	•	•	•	•	•	•	•	•	•	•	
	Take-Up Block	•	•	•	•	•	•	•	•	•	•		
	Cartridge Block	•	•	•	•	•	•	•	•	•	•		
	Hanger Block	•	•	•	•	•	•	•	•	•	•		
TA Series (Tapered Adapter Lock)	Pillow Block	•	•	•	•	•	•	•	•	•	•		
	Flange Block	•	•	•	•	•	•	•	•	•	•		
	Piloted Flange Cartridge	•	•	•	•	•	•	•	•	•	•		
	Cartridge Block	•	•	•	•	•	•	•	•	•	•		
DV Series (Tapered Adapter Lock)	Pillow Block	•	•	•	•	•	•	•	•	•	•		
	Flange Block	•	•	•	•	•	•	•	•	•	•		
	Piloted Flange Cartridge	•	•	•	•	•	•	•	•	•	•		

QAP AND QAAP TWO-BOLT PILLOW BLOCKS

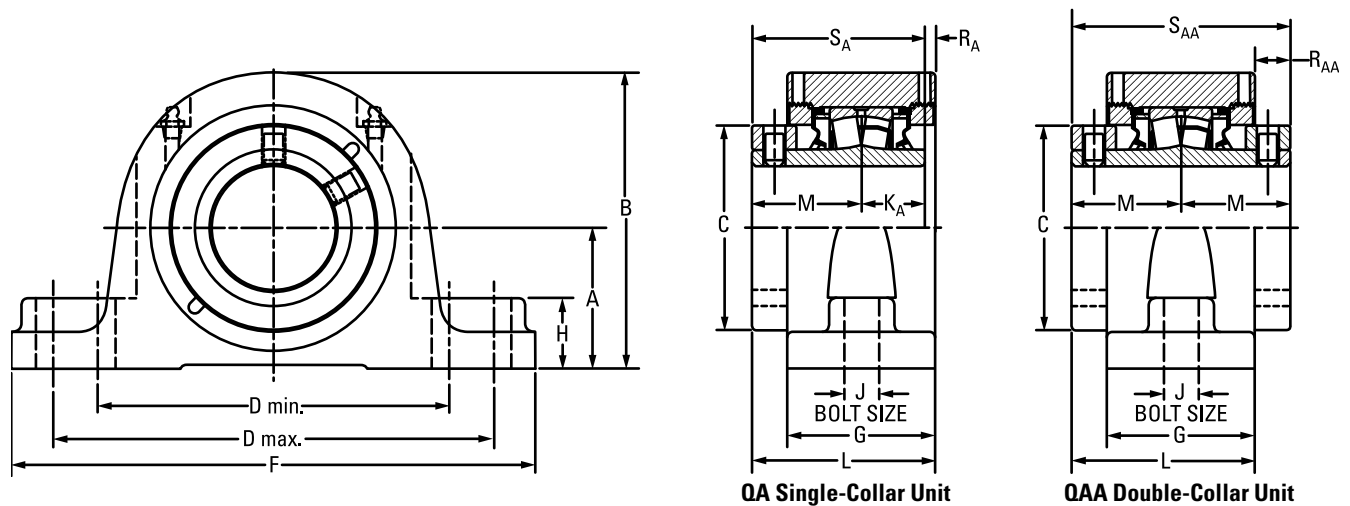

Bearing Part No. ⁽¹⁾	Shaft Dia.	Bearing No.	A	B	C	D min.	D max.	F	G	H	J	KA	L	M	RA	RAA	SA	SAA	Wt.	
	mm in.		mm in.	mm in.	mm in.	mm in.	mm in.	mm in.	mm in.	mm in.	mm in.	mm in.	mm in.	mm in.	mm in.	mm in.	mm in.	mm in.	mm in.	kg lbs.
QAP08A035S	35 mm	22208	47.8	94.7	60.5	119.1	152.4	174.8	57.2	25.4	12	25.4	73.2	44.5	3.3	-	69.9	-	4.1	
QAP08A107S	1 7/16 in.		1.88	3.73	2.38	4.69	6.00	6.88	2.25	1.00	1/2	1.00	2.88	1.75	0.13	-	2.75	-	9	
QAP08A108S	1 1/2 in.	22208	54.1	101.1	60.5	119.1	165.1	200.2	57.2	25.4	12	25.4	73.2	44.5	3.3	-	69.9	-	4.1	
			2.13	3.98	2.38	4.69	6.50	7.88	2.25	1.00	1/2	1.00	2.88	1.75	0.13	-	2.75	-	9	
QAP09A111S	1 11/16 in.	22209	54.1	104.9	66.8	144.8	165.1	200.2	60.2	31.8	12	25.4	78.0	47.8	4.8	-	73.2	-	4.5	
			2.13	4.13	2.63	5.70	6.50	7.88	2.37	1.25	1/2	1.00	3.07	1.88	0.19	-	2.88	-	10	
QAP09A040S	40 mm	22209																		
QAP09A112S	1 3/4 in.		57.2	108.0	66.8	158.8	180.8	225.6	62.0	31.8	16	25.4	78.7	47.8	5.6	-	73.2	-	4.5	
			2.25	4.25	2.63	6.25	7.12	8.88	2.44	1.25	5/8	1.00	3.10	1.88	0.22	-	2.88	-	10	
QAP09A045S	45 mm																			
QAP10A115S	1 15/16 in.	22210																		
QAAP10A115S																				
QAP10A200S	2 in.		57.2	122.2	73.2	152.4	181.1	225.6	62.0	31.8	16	25.4	79.0	47.5	6.1	17.0	72.9	95.3	5.9	
QAAP10A200S			2.25	4.81	2.88	6.00	7.13	8.88	2.44	1.25	5/8	1.00	3.11	1.87	0.24	0.67	2.87	3.75	13	
QAP10A050S	50 mm																			
QAAP10A050S																				
QAP11A203S	2 3/16 in.	22211																		
QAAP11A203S																				
QAP11A204S	2 1/4 in.		63.5	133.4	82.6	165.1	200.2	244.6	66.8	31.8	16	28.7	84.3	50.8	4.8	17.5	79.5	101.6	7.7	
QAAP11A204S			2.50	5.25	3.25	6.50	7.88	9.63	2.63	1.25	5/8	1.13	3.32	2.00	0.19	0.69	3.13	4.00	17	
QAP11A055S	55 mm																			
QAAP11A055S																				
QAP13A060S	60 mm	22213																		
QAAP13A060S																				
QAP13A207S	2 7/16 in.		69.9	147.3	96.8	174.8	219.2	260.4	73.7	35.1	16	31.5	91.4	54.6	5.3	17.8	86.1	109.2	10.0	
QAAP13A207S			2.75	5.80	3.81	6.88	8.63	10.25	2.90	1.38	5/8	1.24	3.60	2.15	0.21	0.70	3.39	4.30	22	
QAP13A208S	2 1/2 in.																			
QAAP13A208S																				
QAP13A065S	65 mm																			
QAAP13A065S																				

⁽¹⁾Bearing part numbers use QA to designate single-collar units (use SA and RA dimensions) and QAA to designate double-collar units (use SAA and RAA dimensions).

Continued on next page.

QAP AND QAAP TWO-BOLT PILLOW BLOCKS – continued

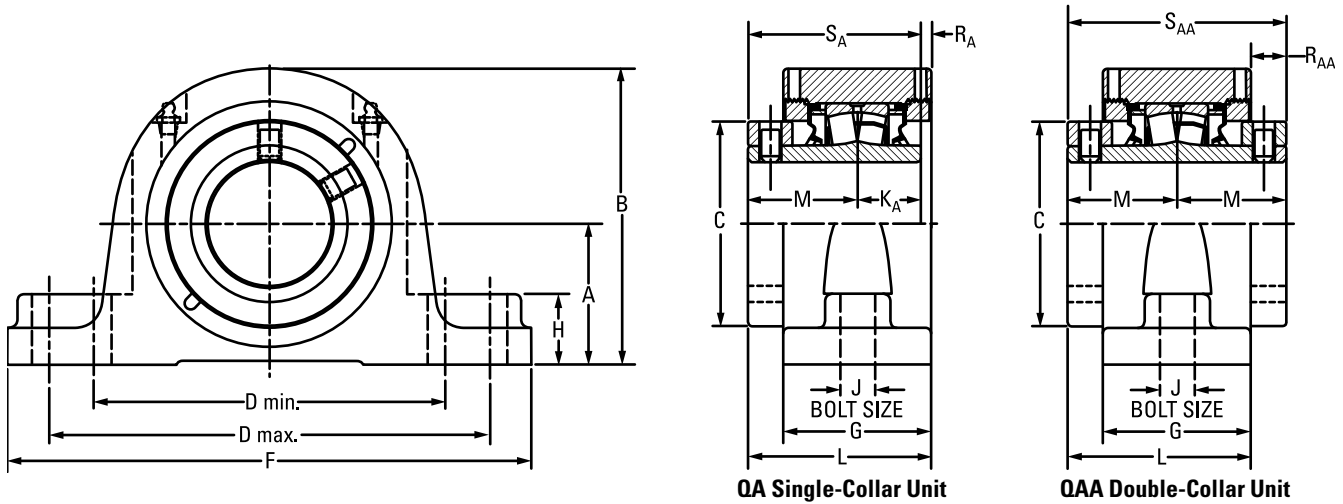

Continued from previous page.

Bearing Part No. ⁽¹⁾	Shaft Dia.	Bearing No.	A	B	C	D min.	D max.	F	G	H	J	K _A	L	M	R _A	R _{AA}	S _A	S _{AA}	Wt.
			mm in.	mm in.	mm in.	mm in.	mm in.	mm in.	mm in.	mm in.	mm in.	mm in.	mm in.	mm in.	mm in.	mm in.	mm in.	mm in.	mm in.
QAP15A211S QAAP15A211S	2 1/16 in.	22215	79.5 3.13	164.3 6.47	109.0 4.29	200.2 7.88	244.6 9.63	295.4 11.63	76.2 3.00	35.1 1.38	20 3/4	31.8 1.25	98.3 3.87	60.2 2.37	6.4 0.25	22.1 0.87	91.9 3.62	120.4 4.74	12.7 28
QAP15A212S QAAP15A212S	2 3/4 in.																		
QAP15A070S QAAP15A070S	70 mm																		
QAP15A215S QAAP15A215S	2 15/16 in.																		
QAP15A300S QAAP15A300S	3 in.																		
QAP15A075S QAAP15A075S	75 mm																		
QAP18A303S QAAP18A303S	3 3/16 in.	22218	95.3 3.75	195.3 7.69	130.3 5.13	238.3 9.38	285.8 11.25	342.9 13.50	86.6 3.41	47.8 1.88	24 7/8	36.6 1.44	109.2 4.30	65.8 2.59	6.9 0.27	22.6 0.89	102.4 4.03	131.6 5.18	20.4 45
QAP18A304S QAAP18A304S	3 1/4 in.																		
QAP18A080S QAAP18A080S	80 mm																		
QAP18A085S QAAP18 A085S	85 mm																		
QAP18A307S QAAP18A307S	3 7/16 in.																		
QAP18A308S QAAP18A308S	3 1/2 in.																		
QAP18A090S QAAP18A090S	90 mm																		
QAP20A315S QAAP20A315S	3 15/16 in.	22220	104.9 4.13	209.8 8.26	152.4 6.00	255.0 10.04	320.0 12.60	362.0 14.25	94.7 3.73	50.8 2.00	24 1	41.4 1.63	122.9 4.84	75.4 2.97	6.1 0.24	28.2 1.11	116.8 4.60	150.9 5.94	26.8 59
QAP20A400S QAAP20A400S	4 in.																		
QAP20A100S QAAP20A100S	100 mm																		

⁽¹⁾Bearing part numbers use QA to designate single-collar units (use S_A and R_A dimensions) and QAA to designate double-collar units (use S_{AA} and R_{AA} dimensions).

QAPL AND QAAPL TWO-BOLT PILLOW BLOCKS

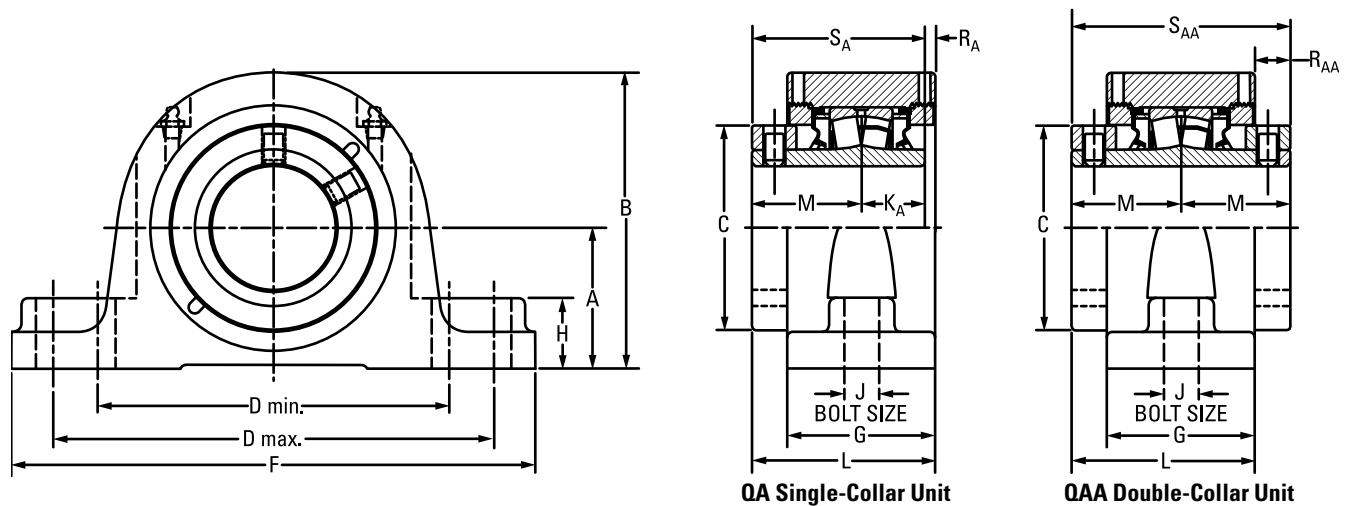

Bearing Part No. ⁽¹⁾	Shaft Dia.	Bearing No.	A	B	C	D min.	D max.	F	G	H	J	KA	L	M	RA	RAA	SA	SAA	Wt.	
	mm in.		mm in.	mm in.	mm in.	mm in.	mm in.	mm in.	mm in.	mm in.	mm in.	mm in.	mm in.	mm in.	mm in.	mm in.	mm in.	mm in.	kg lbs.	
QAPL08A035S	35 mm	22208	47.8 1.88	94.7 3.73	60.5 2.38	119.1 4.69	152.4 6.00	174.8 6.88	57.2 2.25	25.4 1.00	12 ½	25.4 1.00	73.2 2.88	44.5 1.75	3.3 0.13	-	69.9 2.75	-	4.1 9	
QAPL08A107S	1 7/16 in.																			
QAPL08A108S	1 ½ in.																			
QAPL09A040S	40 mm	22209	54.1 2.13	104.9 4.13	66.8 2.63	133.4 5.25	146.1 5.75	181.1 7.13	60.2 2.37	31.8 1.25	12 ½	25.4 1.00	78.0 3.07	47.8 1.88	4.8 0.19	-	73.2 2.88	-	4.5 10	
QAPL09A111S	1 11/16 in.																			
QAPL09A112S	1 ¾ in.																			
QAPL09A045S	45 mm	22210	57.2 2.25	122.2 4.81	73.2 2.88	150.6 5.93	161.5 6.36	212.9 8.38	62.0 2.44	31.8 1.25	16 5/8	25.4 1.00	79.0 3.11	47.5 1.87	6.1 0.24	17.0 0.67	72.9 2.87	95.3 3.75	5.9 13	
QAPL10A115S QAAPL10A115S	1 15/16 in.																			
QAPL10A200S QAAPL10A200S	2 in.																			
QAPL10A050S QAAPL10A050S	50 mm	22211	63.5 2.50	133.4 5.25	82.6 3.25	165.1 6.50	179.3 7.06	225.6 8.88	65.5 2.58	31.8 1.25	16 5/8	28.7 1.13	83.6 3.29	50.8 2.00	4.1 0.16	18.0 0.71	79.5 3.13	101.6 4.00	7.7 17	
QAPL11A203S QAAPL11A203S	2 3/16 in.																			
QAPL11A204S QAAPL11A204S	2 ¼ in.																			
QAPL11A055S QAAPL11A055S	55 mm	22213	69.9 2.75	147.3 5.80	96.8 3.81	173.0 6.81	189.0 7.44	235.0 9.25	73.7 2.90	35.1 1.38	16 5/8	31.5 1.24	91.4 3.60	54.6 2.15	5.3 0.21	17.8 0.70	86.1 3.39	109.2 4.30	10.0 22	
QAPL13A060S QAAPL13A060S	60 mm																			
QAPL13A207S QAAPL13A207S	2 7/16 in.																			
QAPL13A208S QAAPL13A208S	2 ½ in.																			
QAPL13A065S QAAPL13A065S	65 mm																			

⁽¹⁾ Bearing part numbers use QA to designate single-collar units (use SA and RA dimensions) and QAA to designate double-collar units (use SAA and RAA dimensions).

Continued on next page.

QAPL AND QAAPL TWO-BOLT PILLOW BLOCKS – continued

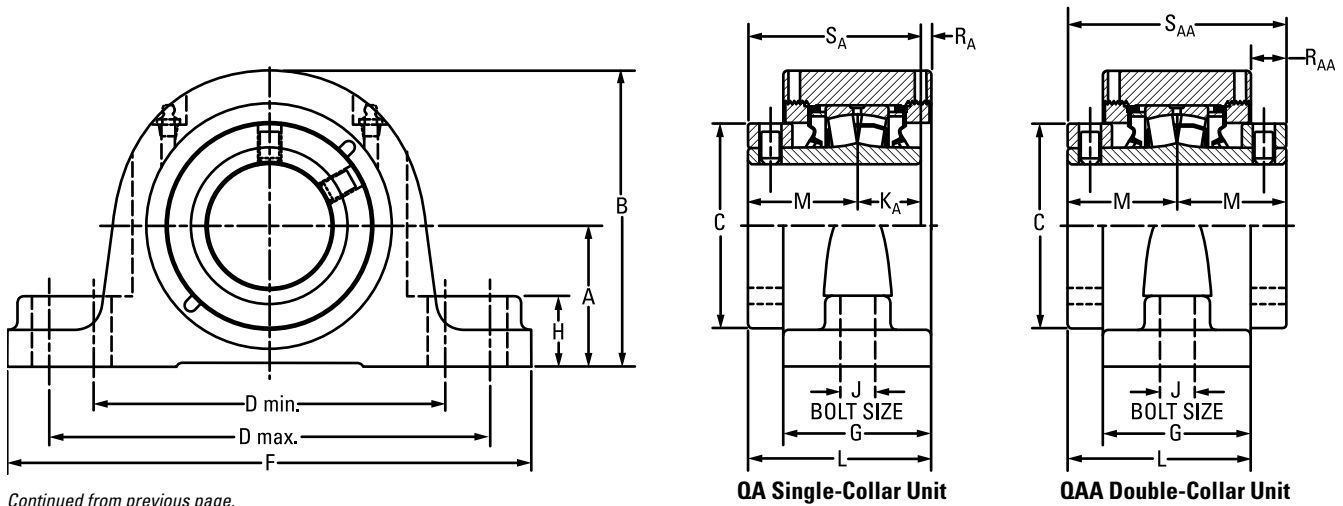

Continued from previous page.

Bearing Part No. ⁽¹⁾	Shaft Dia.	Bearing No.	A	B	C	D min.	D max.	F	G	H	J	K _A	L	M	R _A	R _{AA}	S _A	S _{AA}	Wt.	
	mm in.		mm in.	mm in.	mm in.	mm in.	mm in.	mm in.	mm in.	mm in.	mm in.	mm in.	mm in.	mm in.	mm in.	mm in.	mm in.	mm in.	mm in.	kg lbs.
QAPL15A211S QAAPL15A211S	2 11/16 in.	22215	82.6 3.25	167.4 6.59	109.0 4.29	195.6 7.70	213.4 8.40	265.2 10.44	76.2 3.00	35.1 1.38	20 3/4	31.8 1.25	98.3 3.87	60.2 2.37	6.4 0.25	22.1 0.87	91.9 3.62	120.4 4.74	12.7 28	
QAPL15A212S QAAPL15A212S	2 3/4 in.																			
QAPL15A070S QAAPL15A070S	70 mm																			
QAPL15A215S QAAPL15A215S	2 15/16 in.																			
QAPL15A300S QAAPL15A300S	3 in.																			
QAPL15A075S QAAPL15A075S	75 mm																			
QAPL18A303S QAAPL18A303S	3 3/16 in.	22218	95.3 3.75	195.3 7.69	130.3 5.13	235.0 9.25	273.1 10.75	330.2 13.00	86.6 3.41	47.8 1.88	24 7/8	36.6 1.44	109.2 4.30	65.8 2.59	6.9 0.27	22.6 0.89	102.4 4.03	131.6 5.18	20.4 45	
QAPL18A304S QAAPL18A304S	3 1/4 in.																			
QAPL18A080S QAAPL18A080S	80 mm																			
QAPL18A085S QAAPL18A085S	85 mm																			
QAPL18A307S QAAPL18A307S	3 7/16 in.																			
QAPL18A308S QAAPL18A308S	3 1/2 in.																			
QAPL18A090S QAAPL18A090S	90 mm	22220	108.0 4.25	212.9 8.38	152.4 6.00	255.0 10.04	320.0 12.60	362.0 14.25	94.7 3.73	54.1 2.13	24 1	41.4 1.63	122.9 4.84	75.4 2.97	6.1 0.24	28.2 1.11	116.8 4.60	150.9 5.94	26.8 59	
QAPL20A315S QAAPL20A315S	3 15/16 in.																			
QAPL20A400S QAAPL20A400S	4 in.																			
QAPL20A100S QAAPL20A100S	100 mm																			

⁽¹⁾Bearing part numbers use QA to designate single-collar units (use S_A and R_A dimensions) and QAA to designate double-collar units (use S_{AA} and R_{AA} dimensions).

QASN AND QAASN SN-STYLE TWO-BOLT PILLOW BLOCKS – PURE METRIC DESIGN

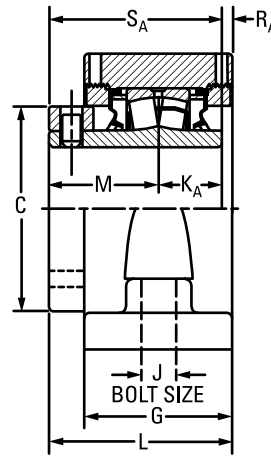
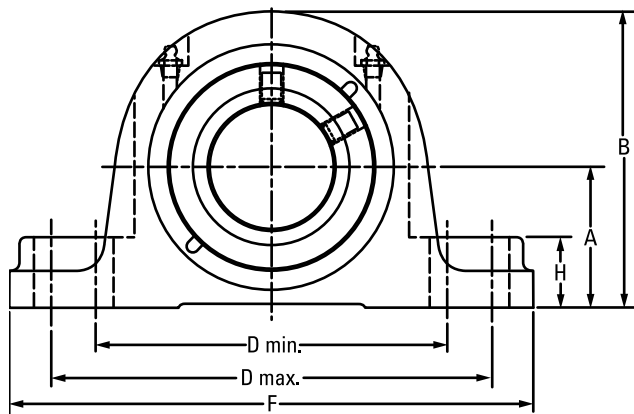

QA Single-Collar Unit

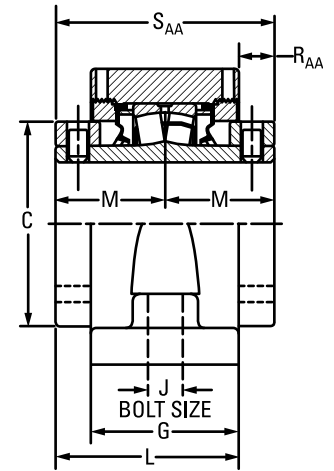

QAA Double-Collar Unit

Bearing Part No. ⁽¹⁾	Shaft Dia.	Bearing No.	A	B	C	D min.	D max.	F	G	H	J	K _A	L	M	R _A	R _{AA}	S _A	S _{AA}	Wt.	
	mm in.		mm in.	mm in.	mm in.	mm in.	mm in.	mm in.	mm in.	mm in.	mm in.	mm in.	mm in.	mm in.	mm in.	mm in.	mm in.	mm in.	mm in.	kg lbs.
QASN08A035S	35 mm	22208	60	111	60.5	159	175	205	62	35	12	25	75	44	5	-	70	-	10.5	
QASN08A107S	1 7/16 in.		2.36	4.37	2.38	6.26	6.89	8.07	2.44	1.38	1/2	1.00	2.95	1.75	0.20	-	2.75	-	23	
QASN08A108S	1 1/2 in.																			
QASN09A040S	40 mm	22209	60	111	66.8	159	175	205	62	35	12	25	79	48	6	-	73	-	10.5	
QASN09A111S	1 11/16 in.		2.36	4.37	2.63	6.26	6.89	8.07	2.44	1.38	1/2	1.00	3.10	1.88	0.22	-	2.88	-	23	
QASN09A112S	1 3/4 in.																			
QASN09A045S	45 mm	22210	70	136	73	183	216	254	68	25	16	25.4	82	48	9	14	73	95	12.7	
QASN10A115S	1 15/16 in.		2.76	5.35	2.87	7.20	8.50	10.00	2.68	0.98	5/8	1.00	3.23	1.87	0.35	0.55	2.87	3.75	28	
QAASN10A200S	2 in.																			
QASN10A050S	50 mm	22211	70	141	83	183	216	254	68	25	16	29	85	51	5	17	80	102	13.2	
QAASN10A050S	50 mm		2.76	5.55	3.27	7.20	8.50	10.00	2.68	0.98	5/8	1.14	3.35	2.01	0.20	0.67	3.15	4.02	29	
QASN11A203S	2 3/16 in.																			
QAASN11A203S	2 3/16 in.																			
QASN11A204S	2 1/4 in.	22213	80	157	96.8	196	235	275	74	35	16	31	92	55	6	18	86	110	15.9	
QAASN11A204S	2 1/4 in.		3.15	6.18	3.81	7.72	9.25	10.83	2.91	1.38	5/8	1.22	3.62	2.17	0.24	0.71	3.39	4.33	35	
QASN11A055S	55 mm																			
QAASN11A055S	55 mm																			
QASN13A060S	60 mm	22215	95	183	109.0	241	279	316	76	34	20	32	98	60	6	22	92	120	20.9	
QAASN13A060S	60 mm		3.74	7.20	4.29	9.49	10.98	12.44	2.99	1.34	3/4	1.26	3.86	2.36	0.24	0.87	3.62	4.72	46	
QASN13A207S	2 7/16 in.																			
QAASN13A207S	2 7/16 in.																			
QASN13A208S	2 1/2 in.																			
QAASN13A208S	2 1/2 in.																			
QASN13A065S	65 mm																			
QAASN13A065S	65 mm																			
QASN15A211S	2 11/16 in.	22215	95	183	109.0	241	279	316	76	34	20	32	98	60	6	22	92	120	20.9	
QAASN15A211S	2 11/16 in.		3.74	7.20	4.29	9.49	10.98	12.44	2.99	1.34	3/4	1.26	3.86	2.36	0.24	0.87	3.62	4.72	46	
QASN15A212S	2 3/4 in.																			
QAASN15A212S	2 3/4 in.																			
QASN15A070S	70 mm																			
QAASN15A070S	70 mm																			
QASN15A215S	2 15/16 in.																			
QAASN15A215S	2 15/16 in.																			
QASN15A300S	3 in.																			
QAASN15A300S	3 in.																			
QASN15A075S	75 mm																			
QAASN15A075S	75 mm																			

⁽¹⁾ Bearing part numbers use QA to designate single-collar units (use S_A and R_A dimensions) and QAA to designate double-collar units (use S_{AA} and R_{AA} dimensions).

Continued on next page.

QASN AND QAASN SN-STYLE TWO-BOLT PILLOW BLOCKS – PURE METRIC DESIGN – continued

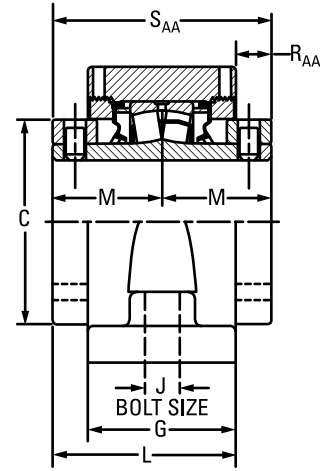
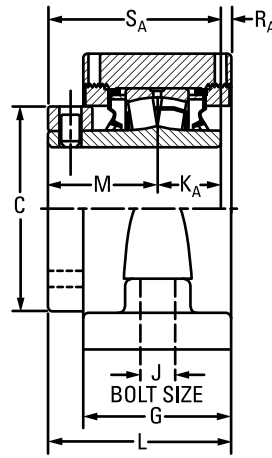
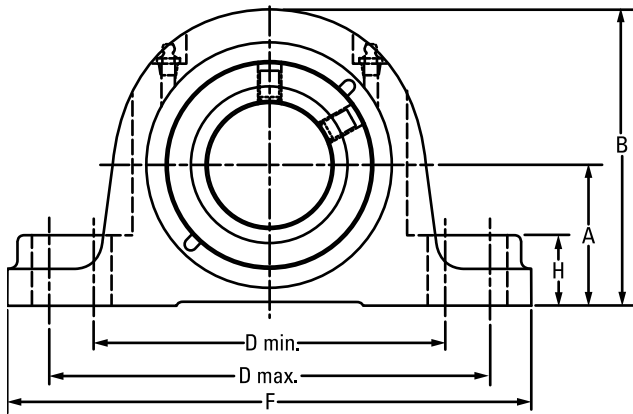

QA Single-Collar Unit

QAA Double-Collar Unit

Continued from previous page.

Bearing Part No. ⁽¹⁾	Shaft Dia.	Bearing No.	A	B	C	D min.	D max.	F	G	H	J	K _A	L	M	R _A	R _{AA}	S _A	S _{AA}	Wt.	
	mm in.		mm in.	mm in.	mm in.	mm in.	mm in.	mm in.	mm in.	mm in.	mm in.	mm in.	mm in.	mm in.	mm in.	mm in.	mm in.	mm in.	mm in.	kg lbs.
QASN18A303S QAASN18A303S	3 3/16 in.	22218	100 3.94	200 7.87	130 5.12	279 10.98	292 11.50	345 13.58	86 3.39	39 1.54	20 3/4	37 1.46	109 4.29	66 2.60	6 0.24	23 0.91	102 4.02	132 5.20	25.5 56	
QASN18A304S QAASN18A304S	3 1/4 in.																			
QASN18A080S QAASN18A080S	80 mm																			
QASN18A085S QAASN18A085S	85 mm																			
QASN18A307S QAASN18A307S	3 7/16 in.	22218	112 4.41	212 8.35	130 5.12	279 10.98	292 11.50	345 13.58	86 3.39	39 1.54	20 3/4	37 1.46	109 4.29	66 2.60	6 0.24	23 0.91	102 4.02	132 5.20	25.5 56	
QASN18A308S QAASN18A308S	3 1/2 in.																			
QASN18A090S QAASN18A090S	90 mm																			
QASN20A315S QAASN20A315S	3 15/16 in.																			
QASN20A400S QAASN20A400S	4 in.	22220	125 4.92	241 9.49	152 5.98	319 12.56	366 14.41	410 16.14	101 3.98	50 1.97	24 7/8	41 1.61	126 4.96	75 2.95	10 0.39	25 0.98	117 4.61	150 5.91	35.9 79	
QASN20A100S QAASN20A100S	100 mm																			
QAASN22A110S	110 mm	22222	140 5.51	255 10.04	160 6.30	332 13.07	365 14.37	410 16.14	105 4.13	39 1.54	24 7/8	-	133 5.24	80 3.15	-	28 1.10	-	160 6.30	35.9 79	
QAASN22A407S	4 7/16 in.	22222	150 5.91	265 10.43	160 6.30	367 14.45	400 15.75	445 17.52	105 4.13	49 1.93	24 7/8	-	133 5.24	80 3.15	-	28 1.10	-	160 6.30	40.0 88	
QAASN22A408S	4 1/2 in.																			
QAASN22A115S	115 mm																			
QAASN26A125S	125 mm	22226	150 5.91	282 11.10	175 6.89	402 15.83	435 17.13	500 19.69	113 4.45	49 1.93	30 1 1/4	-	151 5.94	94 3.70	-	38 1.50	-	188 7.40	40.0 88	
QAASN26A415S	4 15/16 in.																			
QAASN26A500S	5 in.																			
QAASN26A130S	130 mm																			

⁽¹⁾Bearing part numbers use QA to designate single-collar units (use S_A and R_A dimensions) and QAA to designate double-collar units (use S_{AA} and R_{AA} dimensions).

QAAPXT 5000 SERIES TWO-BOLT PILLOW BLOCKS

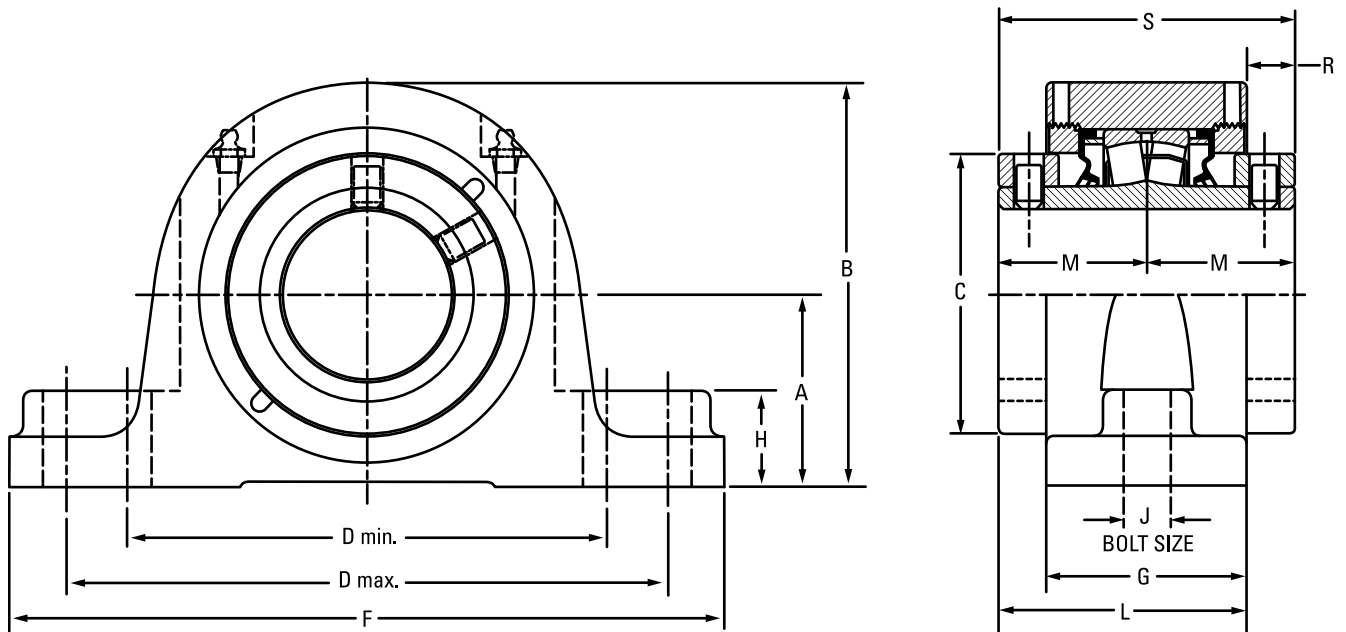

Bearing Part No.	Shaft Dia.	Bearing No.	A	B	C	D min.	D max.	F	G	H	J	L	M	R	S	Wt.
	mm in.		mm in.	mm in.	mm in.	mm in.	mm in.	mm in.	mm in.	mm in.	mm in.	mm in.	mm in.	mm in.	mm in.	kg lbs.
QAAPXT13A060S	60 mm	22213	76.2 3.00	153.7 6.05	96.8 3.81	194.6 7.66	223.0 8.78	285.8 11.25	73.7 2.90	35.1 1.38	20 ¾	91.4 3.60	54.6 2.15	17.8 0.70	109.2 4.30	10.0 22
QAAPXT13A207S	2 7/16 in.															
QAAPXT13A208S	2 1/2 in.															
QAAPXT13A065S	65 mm															
QAAPXT15A211S	2 11/16 in.	22215	88.9 3.50	173.7 6.84	109.0 4.29	230.1 9.06	265.2 10.44	330.2 13.00	75.7 2.98	35.1 1.38	24 7/8	98.0 3.86	60.2 2.37	22.4 0.88	120.4 4.74	12.7 28
QAAPXT15A212S	2 ¾ in.															
QAAPXT15A070S	70 mm															
QAAPXT15A215S	2 15/16 in.															
QAAPXT15A300S	3 in.															
QAAPXT15A075S	75 mm															

QAPF AND QAAPF FOUR-BOLT PILLOW BLOCKS

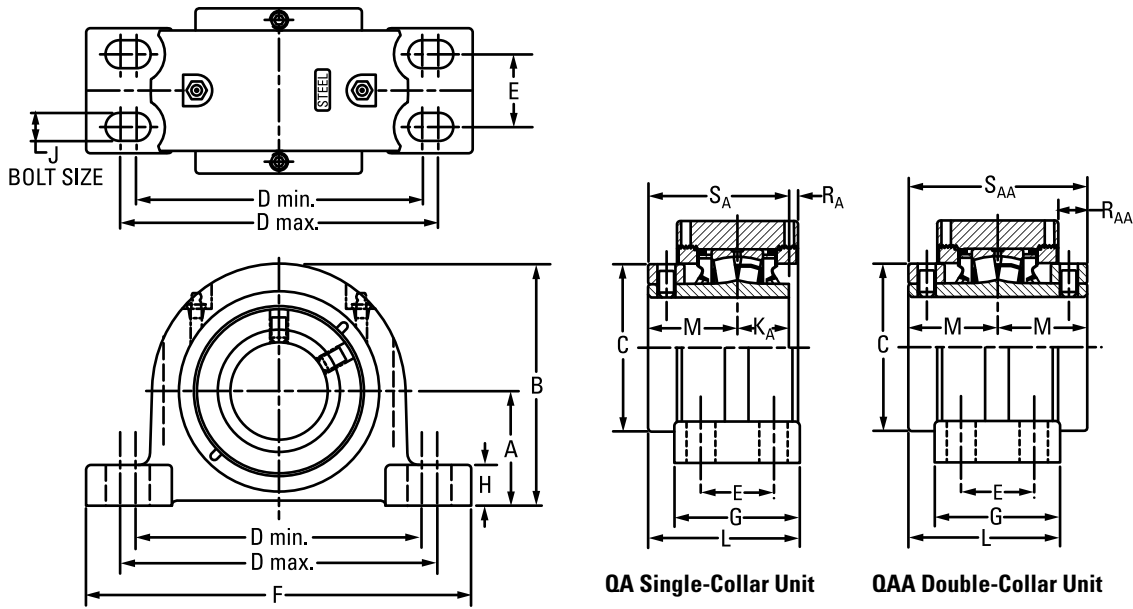

Bearing Part No. ⁽¹⁾	Shaft Dia.	Bearing No.	A	B	C	D min.	D max.	E	F	G	H	J	KA	L	M	RA	RAA	SA	SAA	Wt.	
	mm in.		mm in.	mm in.	mm in.	mm in.	mm in.	mm in.	mm in.	mm in.	mm in.	mm in.	mm in.	mm in.	mm in.	mm in.	mm in.	mm in.	mm in.	mm in.	kg lbs.
QAPF13A060S QAAPF13A060S	60 mm	22213	69.9 2.75	147.3 5.80	96.8 3.81	174.8 6.88	193.8 7.63	44.5 1.75	235.0 9.25	76.2 3.00	24.9 0.98	16 5/8	31.5 1.24	92.7 3.65	54.6 2.15	5.3 0.21	17.8 0.70	86.1 3.39	109.2 4.30	9.1 20	
QAPF13A207S QAAPF13A207S	2 7/16 in.																				
QAPF13A208S QAAPF13A208S	2 1/2 in.																				
QAPF13A065S QAAPF13A065S	65 mm																				
QAPF15A211S QAAPF15A211S	2 11/16 in.	22215	82.6 3.25	167.6 6.60	109.0 4.29	193.0 7.60	231.1 9.10	47.8 1.88	265.2 10.44	79.5 3.13	32.8 1.29	16 5/8	31.8 1.25	100.1 3.94	60.2 2.37	6.1 0.24	22.4 0.88	91.9 3.62	120.4 4.74	12.2 27	
QAPF15A212S QAAPF15A212S	2 3/4 in.																				
QAPF15A070S QAAPF15A070S	70 mm																				
QAPF15A215S QAAPF15A215S	2 15/16 in.																				
QAPF15A300S QAAPF15A300S	3 in.																				
QAPF15A075S QAAPF15A075S	75 mm																				

⁽¹⁾Bearing part numbers use QA to designate single-collar units (use SA and RA dimensions) and QAA to designate double-collar units (use SAA and RAA dimensions).

Continued on next page.

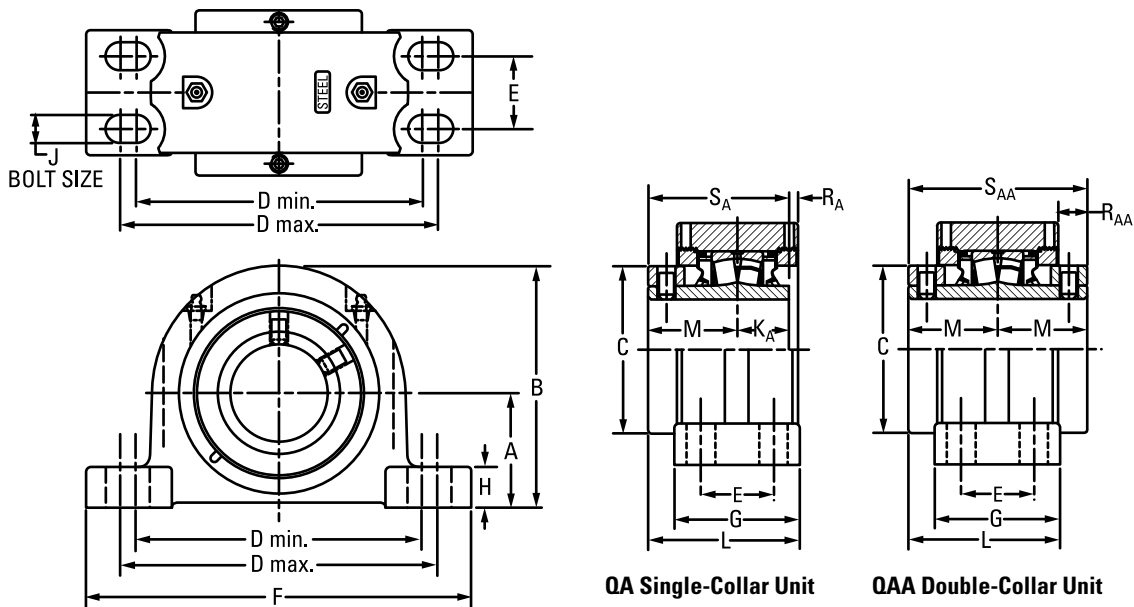

Continued from previous page.

Bearing Part No. ⁽¹⁾	Shaft Dia.	Bearing No.	A	B	C	D min.	D max.	E	F	G	H	J	K _A	L	M	R _A	R _{AA}	S _A	S _{AA}	Wt.	
	mm in.		mm in.	mm in.	mm in.	mm in.	mm in.	mm in.	mm in.	mm in.	mm in.	mm in.	mm in.	mm in.	mm in.	mm in.	mm in.	mm in.	mm in.	mm in.	kg lbs.
QAPF18A303S QAAPF18A303S	3 3/16 in.	22218	95.3 3.75	195.3 7.69	130.3 5.13	225.6 8.88	276.4 10.88	50.8 2.00	312.4 12.30	95.3 3.75	39.6 1.56	20 3/4	36.6 1.44	113.5 4.47	65.8 2.59	7.9 0.31	21.3 0.84	102.4 4.03	131.6 5.18	22.2 49	
QAPF18A304S QAAPF18A304S	3 1/4 in.																				
QAPF18A080S QAAPF18A080S	80 mm																				
QAPF18A085S QAAPF18A085S	85 mm																				
QAPF18A307S QAAPF18A307S	3 7/16 in.																				
QAPF18A308S QAAPF18A308S	3 1/2 in.																				
QAPF18A090S QAAPF18A090S	90 mm																				
QAPF20A315S QAAPF20A315S	3 15/16 in.	22220	108.0 4.25	223.0 8.78	152.4 6.00	276.4 10.88	339.9 13.38	57.2 2.25	378.0 14.88	109.5 4.31	35.6 1.40	20 3/4	41.4 1.63	130.3 5.13	75.4 2.97	8.9 0.35	25.1 0.99	116.6 4.59	150.9 5.94	30.4 67	
QAPF20A400S QAAPF20A400S	4 in.																				
QAPF20A100S QAAPF20A100S	100 mm																				
QAPF22A110S	110 mm	22222	120.7 4.75	233.4 9.19	160.0 6.30	301.8 11.88	368.3 14.50	63.5 2.50	409.7 16.13	120.7 4.75	40.1 1.58	20 3/4	-	140.0 5.51	79.5 3.13	-	28.7 1.13	-	158.8 6.25	37.2 82	
QAAPF22A407S	4 7/16 in.																				
QAAPF22A408S	4 1/2 in.																				
QAAPF22A115S	115 mm	22226	139.7 5.50	279.7 11.01	175.0 6.89	349.3 13.75	403.4 15.88	69.9 2.75	444.5 17.50	128.0 5.04	39.1 1.54	24 7/8	-	158.5 6.24	94.5 3.72	-	36.8 1.45	-	189.0 7.44	60.8 134	
QAAPF26A125S	125 mm																				
QAAPF26A415S	4 15/16 in.																				
QAAPF26A500S	5 in.																				
QAAPF26A130S	130 mm																				

⁽¹⁾Bearing part numbers use QA to designate single-collar units (use S_A and R_A dimensions) and QAA to designate double-collar units (use S_{AA} and R_{AA} dimensions).

QAPR AND QAAPR FOUR-BOLT PILLOW BLOCKS

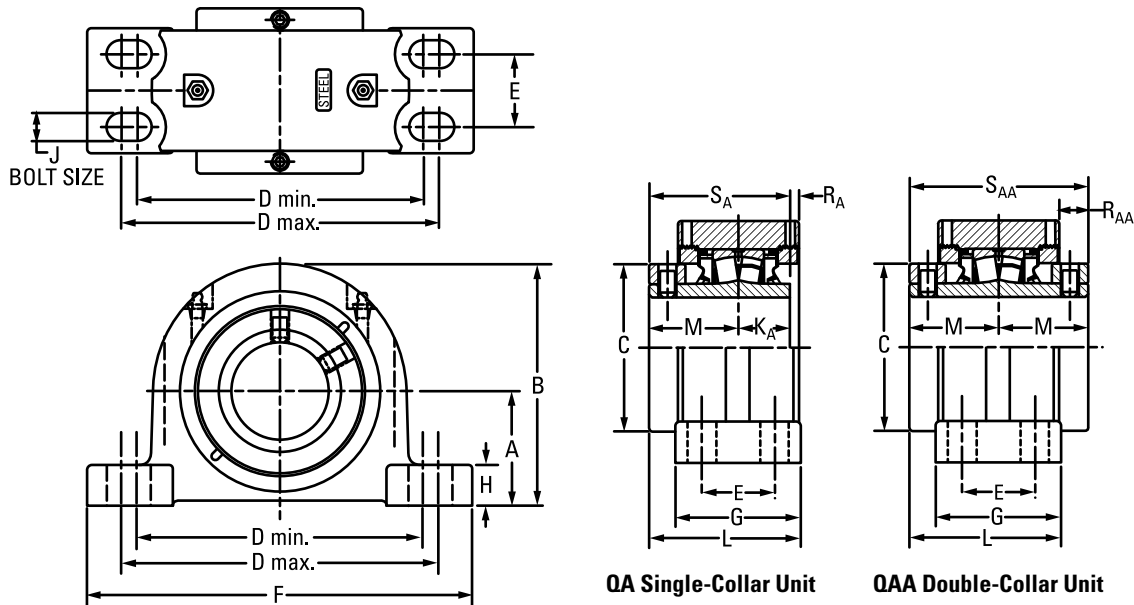

Bearing Part No. ⁽¹⁾	Shaft Dia.	Bearing No.	A	B	C	D min.	D max.	E	F	G	H	J	KA	L	M	RA	RAA	SA	SAA	Wt.	
	mm in.		mm in.	mm in.	mm in.	mm in.	mm in.	mm in.	mm in.	mm in.	mm in.	mm in.	mm in.	mm in.	mm in.	mm in.	mm in.	mm in.	mm in.	mm in.	kg lbs.
QAPR13A060S QAAPR13A060S	60 mm	22213	69.9 2.75	147.3 5.80	96.8 3.81	181.1 7.13	222.3 8.75	47.8 1.88	260.4 10.25	82.6 3.25	24.9 0.98	16 5/8	31.5 1.24	95.8 3.77	54.6 2.15	5.3 0.21	17.8 0.70	86.1 3.39	109.2 4.30	9.1 20	
QAPR13A207S QAAPR13A207S	2 7/16 in.																				
QAPR13A208S QAAPR13A208S	2 1/2 in.																				
QAPR13A065S QAAPR13A065S	65 mm																				
QAPR15A211S QAAPR15A211S	2 11/16 in.	22215	79.5 3.13	164.3 6.47	109.0 4.29	203.2 8.00	243.8 9.60	54.1 2.13	275.1 10.83	85.9 3.38	29.5 1.16	16 5/8	31.8 1.25	102.1 4.02	60.2 2.37	6.1 0.24	22.4 0.88	91.9 3.62	120.4 4.74	12.2 27	
QAPR15A212S QAAPR15A212S	2 3/4 in.																				
QAPR15A070S QAAPR15A070S	70 mm																				
QAPR15A215S QAAPR15A215S	2 15/16 in.																				
QAPR15A300S QAAPR15A300S	3 in.	22218	95.3 3.75	195.3 7.69	130.3 5.13	235.0 9.25	285.8 11.25	60.5 2.38	346.2 13.63	95.3 3.75	39.6 1.56	20 3/4	36.6 1.44	113.5 4.47	65.8 2.59	7.9 0.31	21.3 0.84	102.4 4.03	131.6 5.18	22.2 49	
QAPR15A075S QAAPR15A075S	75 mm																				
QAPR18A303S QAAPR18A303S	3 3/16 in.																				
QAPR18A304S QAAPR18A304S	3 1/4 in.																				
QAPR18A080S QAAPR18A080S	80 mm	22218	95.3 3.75	195.3 7.69	130.3 5.13	235.0 9.25	285.8 11.25	60.5 2.38	346.2 13.63	95.3 3.75	39.6 1.56	20 3/4	36.6 1.44	113.5 4.47	65.8 2.59	7.9 0.31	21.3 0.84	102.4 4.03	131.6 5.18	22.2 49	
QAPR18A085S QAAPR18A085S	85 mm																				
QAPR18A307S QAAPR18A307S	3 7/16 in.																				
QAPR18A308S QAAPR18A308S	3 1/2 in.																				
QAPR18A090S QAAPR18A090S	90 mm																				

⁽¹⁾Bearing part numbers use QA to designate single-collar units (use SA and RA dimensions) and QAA to designate double-collar units (use SAA and RAA dimensions).

QAAPX 5000 SERIES FOUR-BOLT PILLOW BLOCKS

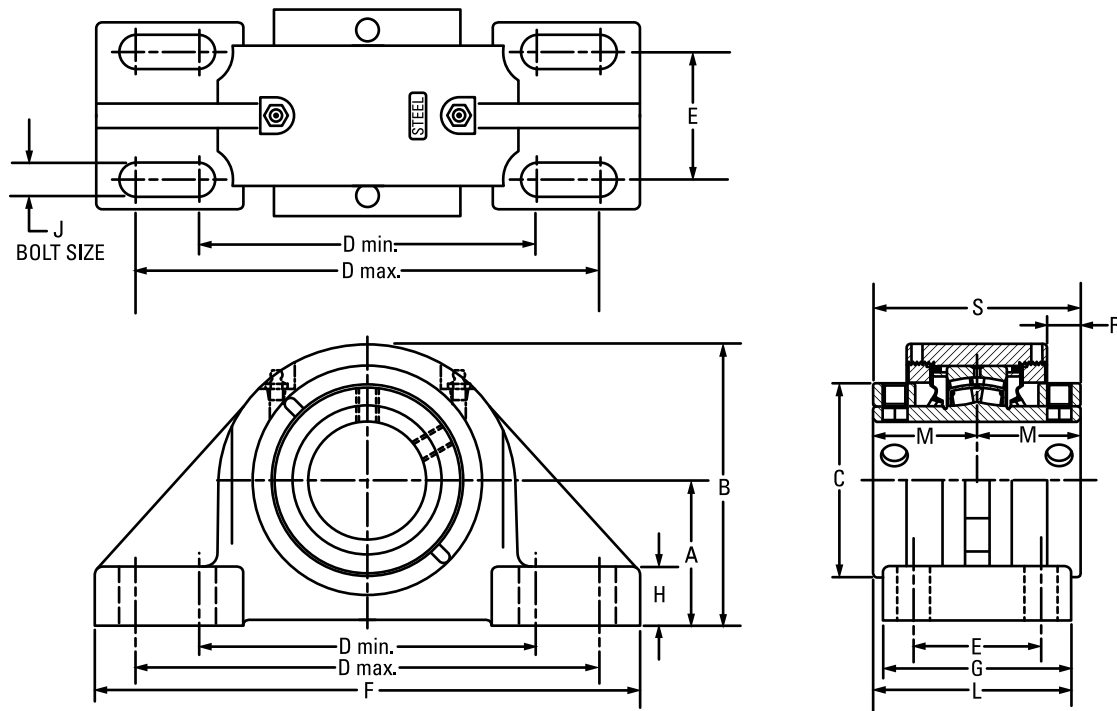

Bearing Part No. ⁽¹⁾	Shaft Dia.	Bearing No.	A	B	C	D min.	D max.	E	F	G	H	J	L	M	R	S	Wt.	
	mm in.		mm in.	mm in.	mm in.	mm in.	mm in.	mm in.	mm in.	mm in.	mm in.	mm in.	mm in.	mm in.	mm in.	mm in.	kg lbs.	
QAAPX13A060S	60 mm	22213	76.2 3.00	153.7 6.05	96.8 3.81	176.3 6.94	242.8 9.56	66.8 2.63	285.8 11.25	98.6 3.88	31.0 1.22	16 5/8	103.9 4.09	54.6 2.15	17.8 0.70	109.2 4.30	13.2 29	
QAAPX13A207S	2 7/16 in.																	
QAAPX13A208S	2 1/2 in.																	
QAAPX13A065S	65 mm	22215	88.9 3.50	173.5 6.83	109.0 4.29	230.1 9.06	265.2 10.44	69.9 2.75	330.2 13.00	108.0 4.25	39.1 1.54	20 3/4	114.3 4.50	60.2 2.37	21.3 0.84	120.4 4.74	20.4 45	
QAAPX15A211S	2 11/16 in.																	
QAAPX15A212S	2 3/4 in.																	
QAAPX15A070S	70 mm	22218	101.6 4.00	201.2 7.92	130.3 5.13	274.6 10.81	309.6 12.19	76.2 3.00	381.0 15.00	120.7 4.75	38.1 1.50	20 3/4	126.2 4.97	65.8 2.59	21.3 0.84	131.6 5.18	29.0 64	
QAAPX18A303S	3 3/16 in.																	
QAAPX18A304S	3 1/4 in.																	
QAAPX18A080S	80 mm	22220	127.0 5.00	239.8 9.44	152.4 6.00	317.5 12.50	355.6 14.00	88.9 3.50	425.5 16.75	139.7 5.50	41.4 1.63	24 7/8	145.0 5.71	75.2 2.96	25.4 1.00	150.4 5.92	44.9 99	
QAAPX18A085S	85 mm																	
QAAPX18A307S	3 7/16 in.																	
QAAPX18A308S	3 1/2 in.	22222	146.1 5.75	273.8 10.78	159.8 6.29	354.1 13.94	395.2 15.56	101.6 4.00	469.9 18.50	158.8 6.25	45.7 1.80	24 1	158.8 6.25	79.5 3.13	28.7 1.13	158.8 6.25	63.0 139	
QAAPX18A090S	90 mm																	
QAAPX20A315S	3 15/16 in.																	
QAAPX20A400S	4 in.	22226	155.7 6.13	283.2 11.15	174.8 6.88	387.4 15.25	425.5 16.75	108.0 4.25	514.4 20.25	171.5 6.75	50.8 2.00	24.0 1 1/8	180.3 7.10	94.5 3.72	37.3 1.47	189.0 7.44	67.6 149	
QAAPX20A100S	100 mm																	
QAAPX22A110S	110 mm																	
QAAPX22A407S	4 7/16 in.																	
QAAPX22A408S	4 1/2 in.																	
QAAPX22A115S	115 mm																	
QAAPX26A125S	125 mm																	
QAAPX26A415S	4 15/16 in.																	
QAAPX26A500S	5 in.																	
QAAPX26A130S	130 mm																	

⁽¹⁾Bearing part numbers use QA to designate single-collar units (use S_A and R_A dimensions) and QAA to designate double-collar units (use S_{AA} and R_{AA} dimensions).

QAC AND QAAC PILOTED FLANGE CARTRIDGES

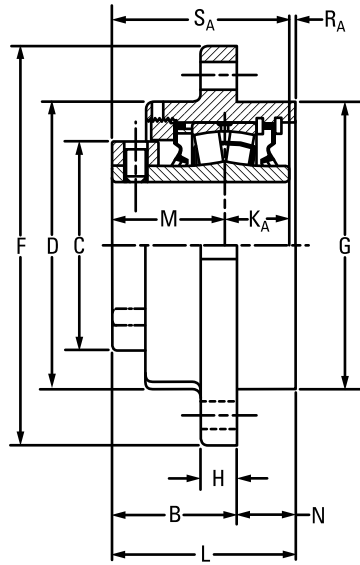
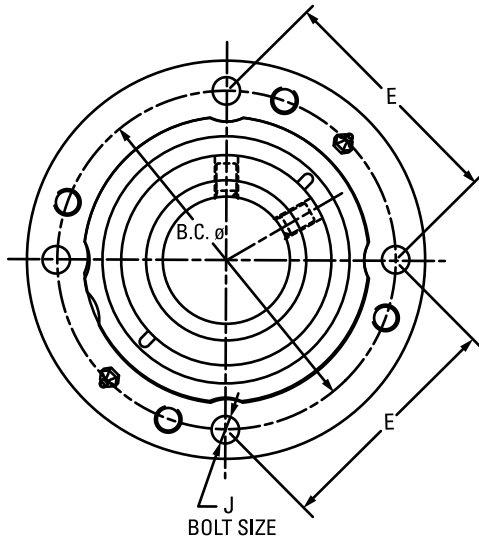

QA Single-Collar Unit

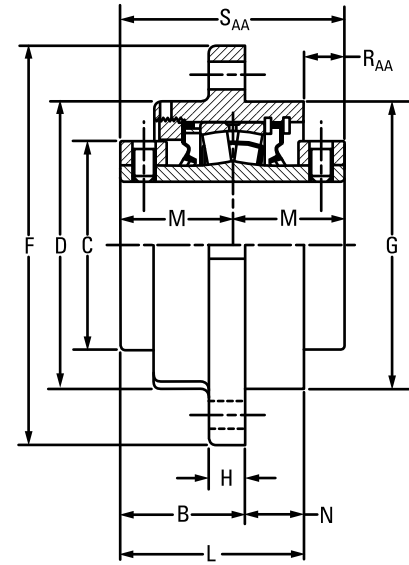

QAA Double-Collar Unit

Bearing Part No. ⁽¹⁾	Shaft Dia.	Bearing No.	B _{FIX}	B _{EXP}	B.C.	C	D	E	F	G ⁽²⁾	H	J	K _A	L _{FIX}	L _{EXP}	M	N	R _A	R _{AA}	S _A	S _{AA}	Wt.	
	mm in.		mm in.	mm in.	mm in.	mm in.	mm in.	mm in.	mm in.	mm in.	mm in.	mm in.	mm in.	mm in.	mm in.	mm in.	mm in.	mm in.	mm in.	mm in.	mm in.	mm in.	kg lbs.
QAC08A035S	35 mm	22208	49.8	51.8	111.3	60.5	92.2	78.5	133.4	92.1	12.7	10	25.4	73.7	75.7	44.5	23.9	3.8	-	69.9	-	3.6	
QAC08A107S	1 7/16 in.		1.96	2.04	4.38	2.38	3.63	3.09	5.25	3.625	0.50	7/16	1.00	2.90	2.98	1.75	0.94	0.15	-	2.75	-	8	
QAC08A108S	1 1/2 in.																						
QAC09A040S	40 mm	22209	54.6	56.6	130.3	66.8	111.3	91.9	155.7	108.0	12.7	10	25.4	77.0	78.2	47.8	22.4	3.8	-	73.2	-	4.1	
QAC09A111S	1 11/16 in.		2.15	2.23	5.13	2.63	4.38	3.62	6.13	4.250	0.50	7/16	1.00	3.03	3.08	1.88	0.88	0.15	-	2.88	-	9	
QAC09A112S	1 3/4 in.																						
QAC09A045S	45 mm	22210	50.5	52.6	136.7	73.2	113.5	96.5	162.1	114.3	16.0	10	25.4	77.5	79.5	47.5	26.9	4.6	18.5	72.9	95.3	4.5	
QAC10A115S QAAC10A115S	1 15/16 in.		1.99	2.07	5.38	2.88	4.47	3.80	6.38	4.500	0.63	7/16	1.00	3.05	3.13	1.87	1.06	0.18	0.73	2.87	3.75	10	
QAC10A050S QAAC10A050S	50 mm																						
QAC11A203S QAAC11A203S	2 3/16 in.	22211	54.4	56.4	152.4	82.6	127.0	107.7	185.4	127.0	14.7	12	28.7	83.1	85.1	50.8	28.7	3.6	18.5	79.5	101.6	5.9	
QAC11A204S QAAC11A204S	2 1/4 in.		2.14	2.22	6.00	3.25	5.00	4.24	7.30	5.000	0.58	1/2	1.13	3.27	3.35	2.00	1.13	0.14	0.73	3.13	4.00	13	
QAC11A055S QAAC11A055S	55 mm																						
QAC13A060S QAAC13A060S	60 mm	22213	60.5	62.5	165.1	96.8	139.7	116.8	193.8	139.7	17.5	12	31.5	88.9	90.9	54.6	28.7	3.0	20.3	86.1	109.2	7.3	
QAC13A207S QAAC13A207S	2 7/16 in.		2.38	2.46	6.50	3.81	5.50	4.60	7.63	5.500	0.69	1/2	1.24	3.50	3.58	2.15	1.13	0.12	0.80	3.39	4.30	16	
QAC13A208S QAAC13A208S	2 1/2 in.																						
QAC13A065S QAAC13A065S	65 mm																						

⁽¹⁾Bearing part numbers use QA to designate single-collar units (use S_A and R_A dimensions) and QAA to designate double-collar units (use S_{AA} and R_{AA} dimensions).

⁽²⁾Pilot tolerance: +0/-0.051 mm (+0/-0.002 in.).

⁽³⁾Six-bolt housing.

Continued on next page.

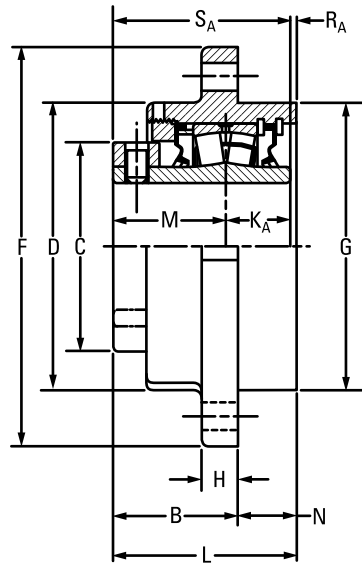
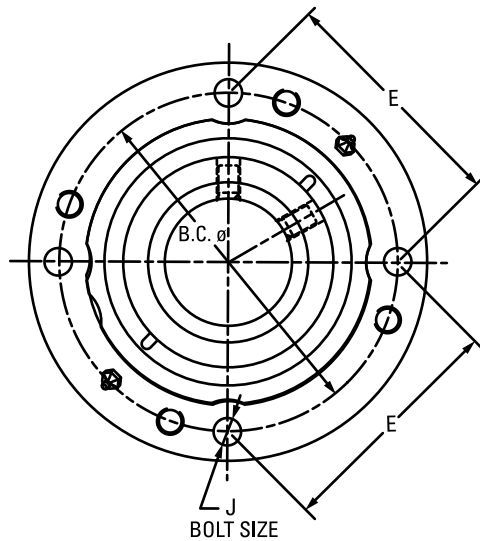

QA Single-Collar Unit

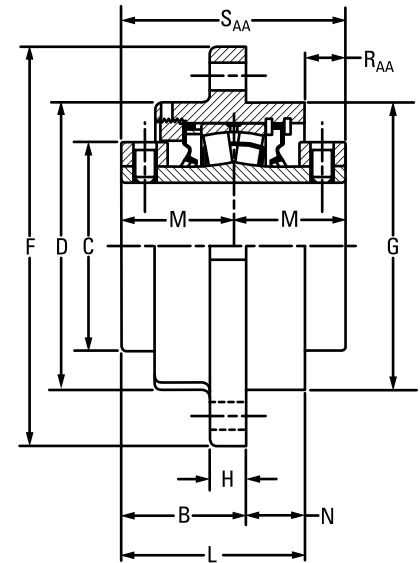

QAA Double-Collar Unit

Continued from previous page.

Bearing Part No. ⁽¹⁾	Shaft Dia.	Bearing No.	B _{FIX}	B _{EXP}	B.C.	C	D	E	F	G ⁽²⁾	H	J	K _A	L _{FIX}	L _{EXP}	M	N	R _A	R _{AA}	S _A	S _{AA}	Wt.	
	mm in.		mm in.	mm in.	mm in.	mm in.	mm in.	mm in.	mm in.	mm in.	mm in.	mm in.	mm in.	mm in.	mm in.	mm in.	mm in.	mm in.	mm in.	mm in.	mm in.	mm in.	kg lbs.
QAC15A211S QAAC15A211S	2 11/16 in.	22215	62.5 2.46	64.5 2.54	190.5 7.50	109.0 4.29	162.1 6.38	134.6 5.30	222.3 8.75	161.9 6.375	20.6 0.81	16 5/8	31.8 1.25	94.2 3.71	96.3 3.79	60.2 2.37	31.8 1.25	2.3 0.09	21.6 0.85	91.9 3.62	120.4 4.74	10.0 22	
QAC15A212S QAAC15A212S	2 3/4 in.																						
QAC15A070S QAAC15A070S	70 mm																						
QAC15A215S QAAC15A215S	2 15/16 in.																						
QAC15A300S QAAC15A300S	3 in.																						
QAC15A075S QAAC15A075S	75 mm																						
QAC18A303S QAAC18A303S	3 3/16 in.	22218	73.2 2.88	75.2 2.96	219.2 8.63	130.3 5.13	187.5 7.38	154.9 6.10	262.6 10.34	187.3 7.375	25.4 1.00	20 3/4	36.6 1.44	106.4 4.19	108.5 4.27	65.8 2.59	33.3 1.31	4.1 0.16	25.1 0.99	102.4 4.03	131.6 5.18	14.5 32	
QAC18A304S QAAC18A304S	3 1/4 in.																						
QAC18A080S QAAC18A080S	80 mm																						
QAC18A085S QAAC18A085S	85 mm																						
QAC18A307S QAAC18A307S	3 7/16 in.																						
QAC18A308S QAAC18A308S	3 1/2 in.																						
QAC18A090S QAAC18A090S	90 mm	22220	72.1 2.84	74.2 2.92	238.3 9.38	152.4 6.00	206.5 8.13	168.4 6.63	276.4 10.88	206.4 8.125	25.4 1.00	20 3/4	41.4 1.63	126.0 4.96	128.0 5.04	75.4 2.97	54.1 2.13	9.4 0.37	24.9 0.98	116.6 4.59	150.9 5.94	19.5 43	
QAC20A315S QAAC20A315S	3 15/16 in.																						
QAC20A400S QAAC20A400S	4 in.																						
QAC20A100S QAAC20A100S	100 mm																						
QAC22A110S	110 mm																						
QAC22A115S ⁽³⁾	115 mm																						
QAAC22A407S ⁽³⁾	4 7/16 in.	22222	78.0 3.07	80.0 3.15	298.5 11.75 ⁽³⁾	160.0 6.30	254.0 10.00	149.4 5.88 ⁽³⁾	342.9 13.50	260.4 10.250	25.4 1.00	20 3/4 ⁽³⁾	-	126.2 4.97	128.3 5.05	79.5 3.13	48.3 1.90	-	32.8 1.29	-	158.8 6.25	32.7 72	
QAAC22A408S ⁽³⁾	4 1/2 in.																						
QAAC22A115S ⁽³⁾	115 mm																						

⁽¹⁾Bearing part numbers use QA to designate single-collar units (use S_A and R_A dimensions) and QAA to designate double-collar units (use S_{AA} and R_{AA} dimensions).

⁽²⁾Pilot tolerance: +0/-0.051 mm (+0/-0.002 in.).

⁽³⁾Six-bolt housing.

QACW AND QAACW PILOTED FLANGE CARTRIDGES

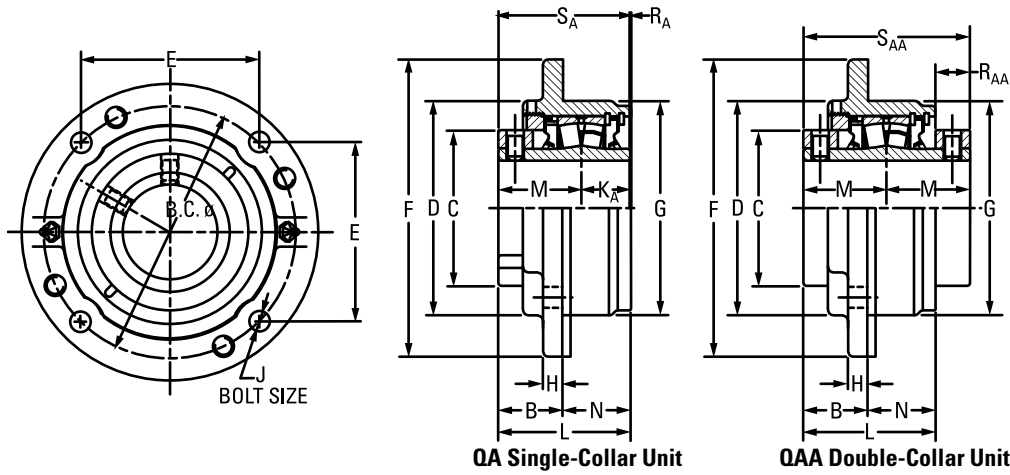

Bearing Part No. ⁽¹⁾	Shaft Dia.	Bearing No.	B _{FIX}	B _{EXP}	B.C.	C	D	E	F	G ⁽²⁾	H	J	K _A	L _{FIX}	L _{EXP}	M	N	R _A	R _{AA}	S _A	S _{AA}	Wt.	
			mm in.	mm in.	mm in.	mm in.	mm in.	mm in.	mm in.	mm in.	mm in.	mm in.	mm in.	mm in.	mm in.	mm in.	mm in.	mm in.	mm in.	mm in.	mm in.	mm in.	mm in.
QACW08A035S	35 mm	22208	38.9	40.9	111.3	60.5	92.2	78.5	133.4	92.1	12.7	10	25.4	73.7	75.7	44.5	35.1	3.8	-	69.9	-	3.6	
QACW08A107S	1 7/16 in.		1.53	1.61	4.38	2.38	3.63	3.09	5.25	3.625	0.50	7/16	1.00	2.90	2.98	1.75	1.38	0.15	-	2.75	-	8	
QACW08A108S	1 1/2 in.																						
QACW09A040S	40 mm	22209	38.9	40.1	130.3	66.8	111.3	91.9	155.7	108.0	10.2	10	25.4	77.0	78.2	47.8	38.1	4.1	-	73.2	-	4.1	
QACW09A111S	1 11/16 in.		1.53	1.58	5.13	2.63	4.38	3.62	6.13	4.250	0.40	7/16	1.00	3.03	3.08	1.88	1.5	0.16	-	2.88	-	9	
QACW09A112S	1 3/4 in.																						
QACW09A045S	45 mm	22210	35.3	37.3	136.7	73.2	113.5	96.5	162.1	114.3	9.7	10	25.4	73.4	75.4	47.5	38.1	0.5	22.6	72.9	95.3	4.5	
QACW10A115S	1 15/16 in.		1.39	1.47	5.38	2.88	4.47	3.80	6.38	4.500	0.38	7/16	1.00	2.89	2.97	1.87	1.50	0.02	0.89	2.87	3.75	10	
QAACW10A200S	2 in.																						
QACW10A050S	50 mm	22211	38.9	40.9	152.4	82.6	126.7	107.7	181.1	127.0	14.2	12	28.7	80.3	82.3	50.8	41.4	0.8	14.7	79.5	101.6	5.9	
QACW11A203S	2 3/16 in.		1.53	1.61	6.00	3.25	4.99	4.24	7.13	5.000	0.56	1/2	1.13	3.16	3.24	2.00	1.63	0.03	0.58	3.13	4.00	13	
QAACW11A204S	2 1/4 in.																						
QACW11A055S	55 mm	22213	47.2	49.3	165.1	96.8	139.7	116.8	193.8	139.7	12.7	12	31.5	90.2	92.2	54.6	42.9	4.3	19.1	86.1	109.2	7.3	
QACW13A060S	60 mm		1.86	1.94	6.50	3.81	5.50	4.60	7.63	5.500	0.50	1/2	1.24	3.55	3.63	2.15	1.69	0.17	0.75	3.39	4.30	16	
QAACW13A207S	2 7/16 in.																						
QACW13A208S	2 1/2 in.																						
QAACW13A208S	65 mm	22215	46.0	48.0	190.5	109.0	162.1	134.6	222.3	161.9	12.7	16	31.8	93.5	95.5	60.2	47.8	1.5	26.9	91.9	120.4	10.0	
QACW15A211S	2 11/16 in.		1.81	1.89	7.50	4.29	6.38	5.30	8.75	6.375	0.50	5/8	1.25	3.68	3.76	2.37	1.88	0.06	1.06	3.62	4.74	22	
QAACW15A215S	2 15/16 in.																						
QACW15A070S	70 mm	3 in.																					
QAACW15A300S	3 in.																						
QACW15A075S	75 mm																						
QAACW15A075S	75 mm																						

⁽¹⁾Bearing part numbers use QA to designate single-collar units (use S_A and R_A dimensions) and QAA to designate double-collar units (use S_{AA} and R_{AA} dimensions).

⁽²⁾Pilot tolerance: +0/-0.051 mm (+0/-0.002 in.).

⁽³⁾Six-bolt housing.

Continued on next page.

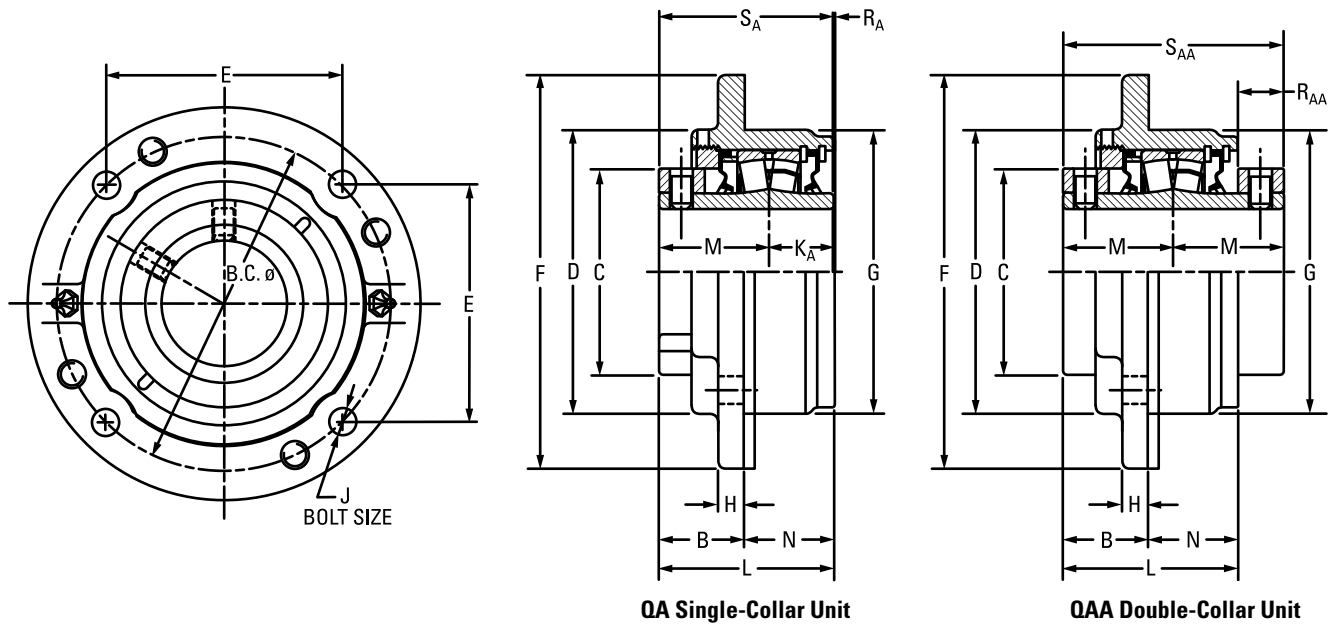

Continued from previous page.

Bearing Part No. ⁽¹⁾	Shaft Dia.	Bearing No.	B	B	B.C.	C	D	E	F	G ⁽²⁾	H	J	K _A	L	L	M	N	R _A	R _{AA}	S _A	S _{AA}	Wt.																					
			FIX	EXP	in.	in.	in.	in.	in.	in.	in.	in.	in.	in.	in.	in.	in.	in.	in.	in.	in.	in.	in.	kg	lbs.																		
QACW18A303S QAACW18A303S	3 3/16 in.	22218	58.2 2.29	60.2 2.37	219.2 8.63	130.3 5.13	187.5 7.38	154.9 6.10	260.4 10.25	187.3 7.375	22.4 0.88	20 3/4	36.6 1.44	105.9 4.17	108.0 4.25	65.8 2.59	47.8 1.88	3.3 0.13	21.3 0.84	102.4 4.03	131.6 5.18	14.5 32																					
QACW18A304S QAACW18A304S	3 1/4 in.																																										
QACW18A080S QAACW18A080S	80 mm																																										
QACW18A085S QAACW18A085S	85 mm																																										
QACW18A307S QAACW18A307S	3 7/16 in.																																										
QACW18A308S QAACW18A308S	3 1/2 in.																																										
QACW18A090S QAACW18A090S	90 mm																																										
QACW20A315S QAACW20A315S	3 15/16 in.																						22220	65.5 2.58	67.6 2.66	238.3 9.38	152.4 6.00	206.5 8.13	168.4 6.63	276.4 10.88	206.4 8.125	25.4 1.00	20 3/4	41.4 1.63	123.4 4.86	125.5 4.94	75.4 2.97	57.9 2.28	6.9 0.27	30.2 1.19	116.6 4.59	150.9 5.94	19.5 43
QACW20A400S QAACW20A400S	4 in.																																										
QACW20A100S QAACW20A100S	100 mm																																										
QAACW22A110S	110 mm	22222	62.0 2.44	64.0 2.52	298.5 11.75 ⁽³⁾	160.0 6.30	254.0 10.00	149.4 5.88 ⁽³⁾	342.9 13.50	260.4 10.250	25.4 1.00	20 3/4 ⁽³⁾	130.0 5.12	132.1 5.20	79.5 3.13	68.3 2.69	-	28.7 1.13	-	-	158.8 6.25	32.7 72																					
QAACW22A407S ⁽³⁾	4 7/16 in.																																										
QAACW22A408S ⁽³⁾	4 1/2 in.																																										
QAACW22A115S ⁽³⁾	115 mm	22226	73.7 2.90	75.7 2.98	323.9 12.75 ⁽³⁾	175.0 6.89	266.7 10.50	162.1 6.38 ⁽³⁾	374.7 14.75	279.4 11.000	26.2 1.03	24 7/8 ⁽³⁾	153.2 6.03	155.2 6.11	94.5 3.72	78.0 3.07	-	35.8 1.41	-	-	189.0 7.44	46.3 102																					
QAACW26A125S ⁽³⁾	125 mm																																										
QAACW26A415S ⁽³⁾	4 15/16 in.																																										
QAACW26A500S ⁽³⁾	5 in.																																										
QAACW26A130S ⁽³⁾	130 mm																																										

⁽¹⁾ Bearing part numbers use QA to designate single-collar units (use S_A and R_A dimensions) and QAA to designate double-collar units (use S_{AA} and R_{AA} dimensions).

⁽²⁾ Pilot tolerance: +0/-0.051 mm (+0/-0.002 in.).

⁽³⁾ Six-bolt housing.

QAF AND QAAF SQUARE FLANGE BLOCKS

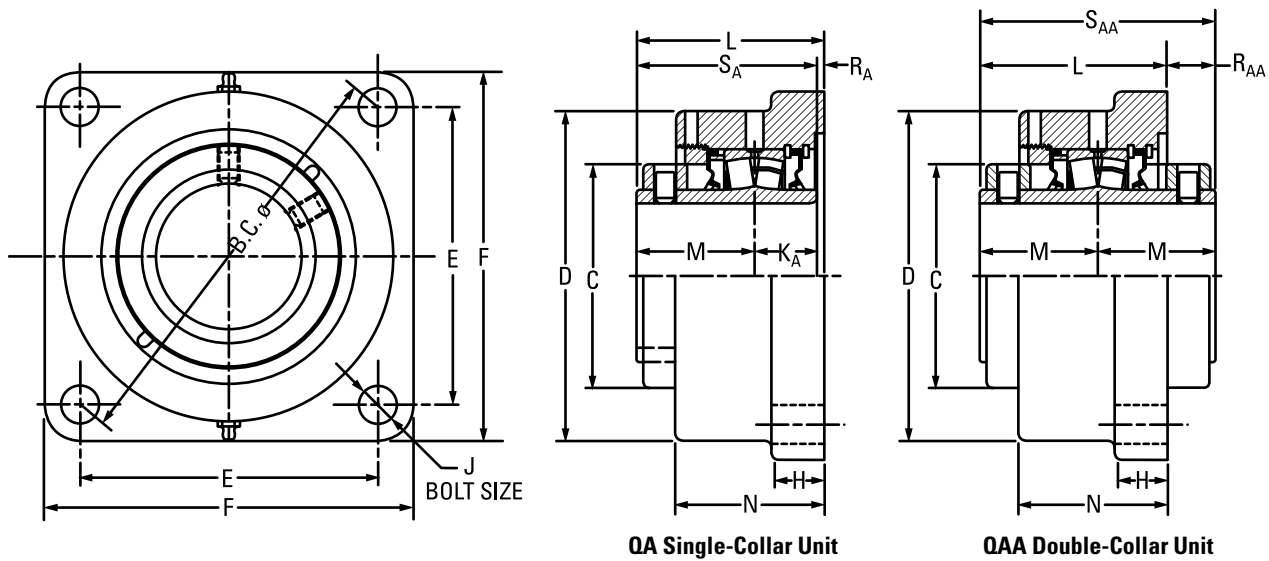

QA Single-Collar Unit

QAA Double-Collar Unit

Bearing Part No. ⁽¹⁾	Shaft Dia.	Bearing No.	B.C.	C	D	E	F	H	J	KA	L FIX	L EXP	M	N	RA	RAA	SA	SAA	Wt.
	mm in.		mm in.	mm in.	mm in.	mm in.	mm in.	mm in.	mm in.	mm in.	mm in.	mm in.	mm in.	mm in.	mm in.	mm in.	mm in.	mm in.	kg lbs.
QAF08A035S	35 mm	22208	125.7	60.5	93.7	88.9	117.6	22.4	12	25.4	72.9	74.9	44.5	57.2	3.0	-	69.9	-	4.5
QAF08A107S	1 7/16 in.		4.95	2.38	3.69	3.50	4.63	0.88	1/2	1.00	2.87	2.95	1.75	2.25	0.12	-	2.75	-	10
QAF08A108S	1 1/2 in.	22208	148.3	60.5	108.0	104.9	136.7	22.4	12	25.4	73.7	75.7	44.5	59.4	3.8	-	69.9	-	4.5
			5.84	2.38	4.25	4.13	5.38	0.88	1/2	1.00	2.90	2.98	1.75	2.34	0.15	-	2.75	-	10
QAF09A040S	40 mm	22209	148.3	66.8	118.4	104.9	136.7	22.4	12	25.4	79.5	81.5	47.8	63.5	6.4	-	73.2	-	5.0
QAF09A111S	1 11/16 in.		5.84	2.63	4.66	4.13	5.38	0.88	1/2	1.00	3.13	3.21	1.88	2.50	0.25	-	2.88	-	11
QAF09A112S	1 3/4 in.	22209	157.2	66.8	118.4	111.3	143.0	22.4	12	25.4	79.5	81.5	47.8	63.5	6.4	-	73.2	-	5.0
QAF09A045S	45 mm		6.19	2.63	4.66	4.38	5.63	0.88	1/2	1.00	3.13	3.21	1.88	2.50	0.25	-	2.88	-	11
QAF10A115S	1 15/16 in.	22210	157.2	73.2	120.7	111.3	139.7	22.4	12	25.4	80.8	82.8	47.5	65.0	7.9	15.2	72.9	95.3	5.0
QAAF10A115S																			
QAF10A200S	2 in.		6.19	2.88	4.75	4.38	5.50	0.88	1/2	1.00	3.18	3.26	1.87	2.56	0.31	0.60	2.87	3.75	11
QAAF10A200S																			
QAF10A050S	50 mm	22211	175.0	82.6	130.3	124.0	157.2	25.4	16	28.7	83.1	85.1	50.8	66.8	3.8	18.5	79.5	101.6	6.4
QAAF10A050S																			
QAF11A203S	2 3/16 in.		6.89	3.25	5.13	4.88	6.19	1.00	5/8	1.13	3.27	3.35	2.00	2.63	0.15	0.73	3.13	4.00	14
QAAF11A203S																			
QAF11A204S	2 1/4 in.		6.89	3.25	5.13	4.88	6.19	1.00	5/8	1.13	3.27	3.35	2.00	2.63	0.15	0.73	3.13	4.00	14
QAAF11A204S																			
QAF11A055S	55 mm	22213	193.0	96.8	146.1	136.7	168.4	25.4	16	31.5	89.2	91.2	54.6	72.4	3.0	20.1	86.1	109.2	7.7
QAAF11A055S																			
QAF13A060S	60 mm		7.60	3.81	5.75	5.38	6.63	1.00	5/8	1.24	3.51	3.59	2.15	2.85	0.12	0.79	3.39	4.30	17
QAAF13A060S																			
QAF13A207S	2 7/16 in.		7.60	3.81	5.75	5.38	6.63	1.00	5/8	1.24	3.51	3.59	2.15	2.85	0.12	0.79	3.39	4.30	17
QAAF13A207S																			
QAF13A208S	2 1/2 in.		7.60	3.81	5.75	5.38	6.63	1.00	5/8	1.24	3.51	3.59	2.15	2.85	0.12	0.79	3.39	4.30	17
QAAF13A208S																			
QAF13A065S	65 mm	22213	193.0	96.8	146.1	136.7	168.4	25.4	16	31.5	89.2	91.2	54.6	72.4	3.0	20.1	86.1	109.2	7.7
QAAF13A065S																			

⁽¹⁾Bearing part numbers use QA to designate single-collar units (use SA and RA dimensions) and QAA to designate double-collar units (use SAA and RAA dimensions).

Continued on next page.

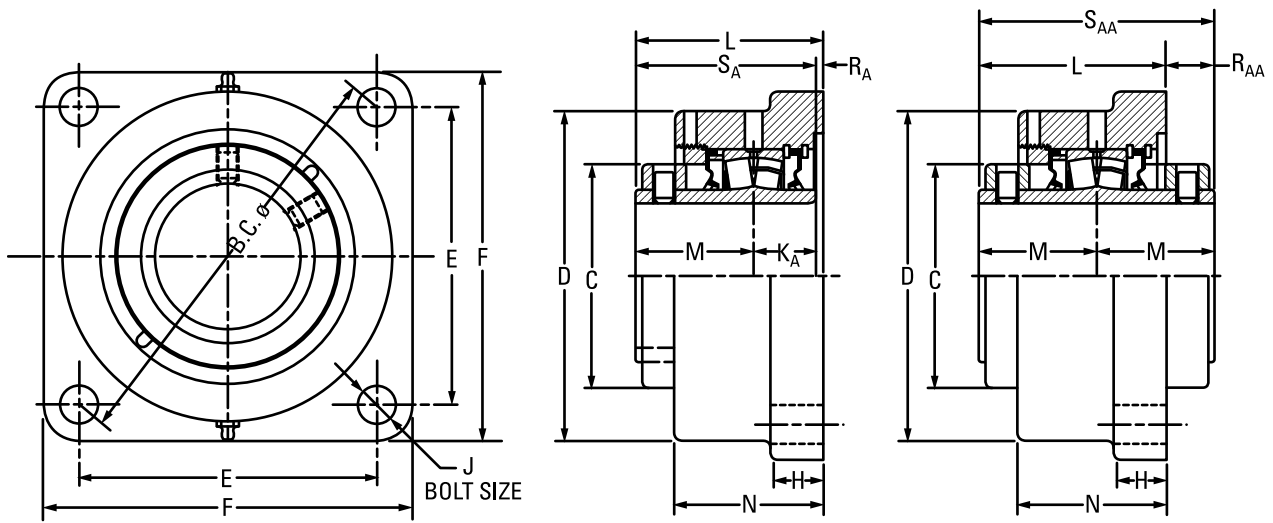

QA Single-Collar Unit

QAA Double-Collar Unit

Continued from previous page.

Bearing Part No. ⁽¹⁾	Shaft Dia.	Bearing No.	B.C.	C	D	E	F	H	J	K _A	L _{FIX}	L _{EXP}	M	N	R _A	R _{AA}	S _A	S _{AA}	Wt.	
	mm in.		mm in.	mm in.	mm in.	mm in.	mm in.	mm in.	mm in.	mm in.	mm in.	mm in.	mm in.	mm in.	mm in.	mm in.	mm in.	mm in.	mm in.	kg lbs.
QAF15A211S QAAF15A211S	2 11/16 in.	22215	215.4 8.48	109.0 4.29	168.9 6.65	152.4 6.00	189.0 7.44	26.9 1.06	20 3/4	31.8 1.25	95.8 3.77	97.8 3.85	60.2 2.37	76.2 3.00	3.8 0.15	24.6 0.97	91.9 3.62	120.4 4.74	10.4 23	
QAF15A212S QAAF15A212S	2 3/4 in.																			
QAF15A070S QAAF15A070S	70 mm																			
QAF15A215S QAAF15A215S	2 15/16 in.																			
QAF15A300S QAAF15A300S	3 in.																			
QAF15A075S QAAF15A075S	75 mm																			
QAF18A303S QAAF18A303S	3 3/16 in.	22218	251.7 9.91	130.3 5.13	193.8 7.63	177.8 7.00	219.2 8.63	33.3 1.31	20 3/4	36.6 1.44	107.2 4.22	109.2 4.30	65.8 2.59	84.1 3.31	4.8 0.19	24.4 0.96	102.4 4.03	131.6 5.18	15.9 35	
QAF18A304S QAAF18A304S	3 1/4 in.																			
QAF18A080S QAAF18A080S	80 mm																			
QAF18A085S QAAF18A085S	85 mm																			
QAF18A307S QAAF18A307S	3 7/16 in.																			
QAF18A308S QAAF18A308S	3 1/2 in.																			
QAF18A090S QAAF18A090S	90 mm	22220	278.4 10.96	152.4 6.00	224.0 8.82	196.9 7.75	253.2 9.97	38.1 1.50	24 7/8	41.4 1.63	126.0 4.96	128.0 5.04	75.4 2.97	103.1 4.06	9.4 0.37	24.1 0.95	116.6 4.59	150.4 5.92	24.9 55	
QAF20A315S QAAF20A315S	3 15/16 in.																			
QAF20A400S QAAF20A400S	4 in.																			
QAF20A100S QAAF20A100S	100 mm																			
QAF22A110S QAAF22A110S	110 mm																			
QAF22A407S QAAF22A407S	4 7/16 in.																			
QAF22A408S QAAF22A408S	4 1/2 in.	22222	314.5 12.38	160.0 6.30	222.3 8.75	222.3 8.75	276.4 10.88	38.1 1.50	24 7/8	-	135.6 5.34	137.7 5.42	79.5 3.13	106.9 4.21	-	23.4 0.92	-	158.8 6.25	28.6 63	
QAF22A115S QAAF22A115S	115 mm																			

⁽¹⁾Bearing part numbers use QA to designate single-collar units (use S_A and R_A dimensions) and QAA to designate double-collar units (use S_{AA} and R_{AA} dimensions).

QAFL AND QAAFL SQUARE FLANGE BLOCKS

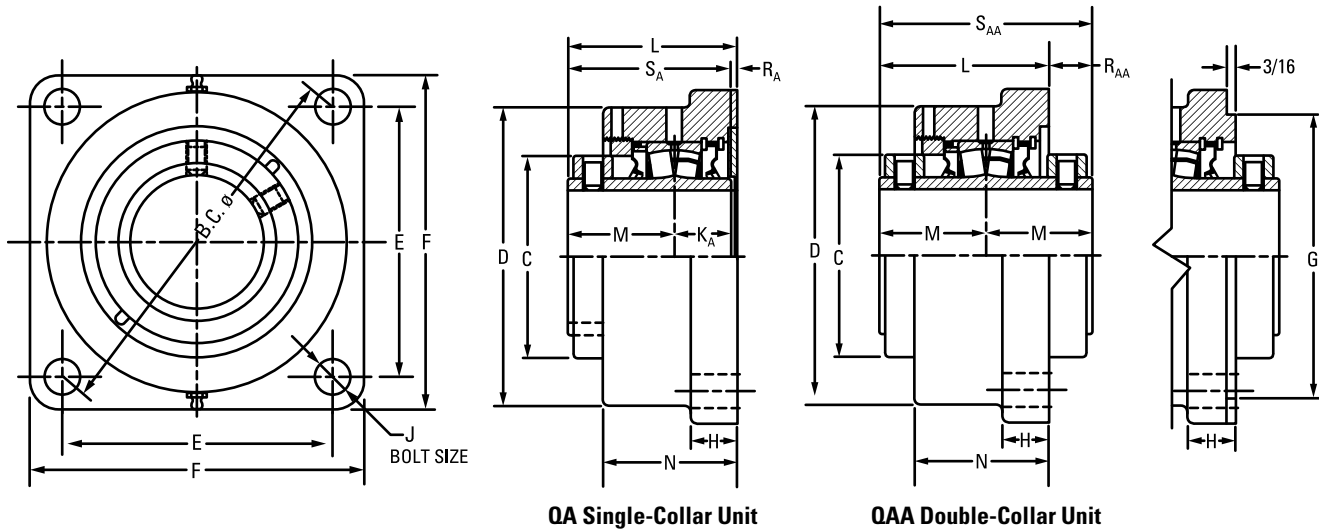

Bearing Part No. ⁽¹⁾	Shaft Dia.	Bearing No.	B.C.	C	D	E	F	G ⁽²⁾⁽³⁾⁽⁴⁾	H	J	K _A	L _{FIX}	L _{EXP}	M	N	R _A	R _{AA}	S _A	S _{AA}	Wt.	
	mm in.		mm in.	mm in.	mm in.	mm in.	mm in.	mm in.	mm in.	mm in.	mm in.	mm in.	mm in.	mm in.	mm in.	mm in.	mm in.	mm in.	mm in.	mm in.	kg lbs.
QAFL08A035S	35 mm	22208	127.0	60.5	93.7	89.9	117.6	N/A	22.4	12	25.4	72.9	74.9	44.5	57.2	3.0	-	69.9	-	4.5	
QAFL08A107S	1 7/16 in.		5.00	2.38	3.69	3.54	4.63	N/A	0.88	1/2	1.00	2.87	2.95	1.75	2.25	0.12	-	2.75	-	10	
QAFL08A108S	1 1/2 in.																				
QAFL09A040S	40 mm	22209	139.7	66.8	118.4	98.8	136.7	N/A	22.4	12	25.4	79.5	81.5	47.8	63.5	6.6	-	73.2	-	5.0	
QAFL09A111S	1 11/16 in.		5.50	2.63	4.66	3.89	5.38	N/A	0.88	1/2	1.00	3.13	3.21	1.88	2.50	0.26	-	2.88	-	11	
QAFL09A112S	1 3/4 in.																				
QAFL09A045S	45 mm	22210	146.1	73.2	120.7	103.4	131.8	N/A	23.1	12	25.4	80.8	82.8	47.5	62.5	7.9	15.2	72.9	95.3	5.0	
QAFL10A115S	1 15/16 in.		5.75	2.88	4.75	4.07	5.19	N/A	0.91	1/2	1.00	3.18	3.26	1.87	2.46	0.31	0.60	2.87	3.75	11	
QAFL10A200S	2 in.																				
QAFL10A050S	50 mm	22211	162.1	82.6	131.8	114.3	149.4	N/A	19.1	16	28.7	83.3	85.3	50.8	66.8	3.8	18.3	79.5	101.6	6.4	
QAFL11A203S	2 3/16 in.		6.38	3.25	5.19	4.50	5.88	N/A	0.75	5/8	1.13	3.28	3.36	2.00	2.63	0.15	0.72	3.13	4.00	14	
QAFL11A204S	2 1/4 in.																				
QAFL11A055S	55 mm	22213	171.5	96.8	146.1	121.2	157.2	N/A	25.4	16	31.5	89.2	91.2	54.6	72.6	3.0	20.1	86.1	109.2	7.7	
QAFL13A060S	60 mm		6.75	3.81	5.75	4.77	6.19	N/A	1.00	5/8	1.24	3.51	3.59	2.15	2.86	0.12	0.79	3.39	4.30	17	
QAFL13A207S	2 7/16 in.																				
QAFL13A208S	2 1/2 in.																				
QAFL13A065S	65 mm																				

⁽¹⁾Bearing part numbers use QA to designate single-collar units (use S_A and R_A dimensions) and QAA to designate double-collar units (use S_{AA} and R_{AA} dimensions).

⁽²⁾Pilot tolerance: +0/-0.05 mm (+0/-0.002 in.).

⁽³⁾Add (p) to the end of the housing designation in the part number to order with pilot using G dimension.

⁽⁴⁾Piloted flange blocks will be quoted (price and delivery) upon request. For optional spigot on flange side, insert the letter P as seen in the following example: QMFP**J***S.

Continued on next page.

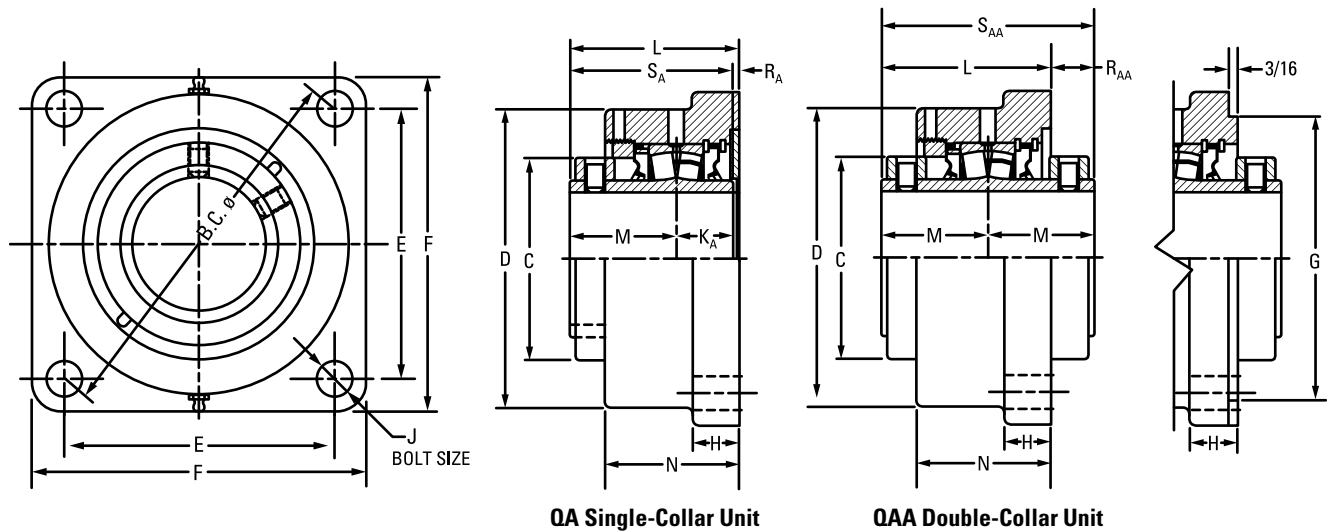

Continued from previous page.

Bearing Part No. ⁽¹⁾	Shaft Dia.	Bearing No.	B.C.	C	D	E	F	G ⁽²⁾⁽³⁾⁽⁴⁾	H	J	KA	L _{FIX}	L _{EXP}	M	N	RA	RAA	SA	SAA	Wt.
	mm in.		mm in.	mm in.	mm in.	mm in.	mm in.	mm in.	mm in.	mm in.	mm in.	mm in.	mm in.	mm in.	mm in.	mm in.	mm in.	mm in.	mm in.	kg lbs.
QAF15A211S QAAF15A211S	2 11/16 in.	22215	200.2 7.88	109.0 4.29	168.4 6.63	141.2 5.56	182.6 7.19	N/A	26.9 1.06	20 3/4	31.8 1.25	95.8 3.77	97.8 3.85	60.2 2.37	74.4 2.93	3.8 0.15	24.6 0.97	91.9 3.62	120.4 4.74	10.4 23
QAF15A212S QAAF15A212S	2 3/4 in.																			
QAF15A070S QAAF15A070S	70 mm																			
QAF15A215S QAAF15A215S	2 15/16 in.																			
QAF15A300S QAAF15A300S	3 in.																			
QAF15A075S QAAF15A075S	75 mm																			
QAF18A303S QAAF18A303S	3 3/16 in.	22218	241.3 9.50	130.3 5.13	193.8 7.63	170.7 6.72	212.9 8.38	187.33 7.375	32.5 1.28	20 3/4	36.6 1.44	106.4 4.19	108.5 4.27	65.8 2.59	86.4 3.40	4.1 0.16	25.1 0.99	102.4 4.03	131.6 5.18	15.9 35
QAF18A304S QAAF18A304S	3 1/4 in.																			
QAF18A080S QAAF18A080S	80 mm																			
QAF18A085S QAAF18A085S	85 mm																			
QAF18A307S QAAF18A307S	3 7/16 in.																			
QAF18A308S QAAF18A308S	3 1/2 in.																			
QAF18A090S QAAF18A090S	90 mm	22220	273.1 10.75	152.4 6.00	229.6 9.04	193.0 7.60	241.3 9.50	215.90 8.500	38.1 1.50	24 1	41.4 1.63	132.3 5.21	134.4 5.29	75.4 2.97	104.6 4.12	15.7 0.62	18.0 0.71	116.6 4.59	150.4 5.92	24.9 55
QAF20A315S QAAF20A315S	3 15/16 in.																			
QAF20A400S QAAF20A400S	4 in.																			
QAF20A100S QAAF20A100S	100 mm																			

⁽¹⁾ Bearing part numbers use QA to designate single-collar units (use SA and RA dimensions) and QAA to designate double-collar units (use SAA and RAA dimensions).

⁽²⁾ Pilot tolerance: +0/-0.05 mm (+0/-0.002 in.).

⁽³⁾ Add (p) to the end of the housing designation in the part number to order with pilot using G dimension.

⁽⁴⁾ Piloted flange blocks will be quoted (price and delivery) upon request. For optional spigot on flange side, insert the letter P as seen in the following example: QMFP**J***S.

QAAFX 5000 SERIES FLANGE BLOCKS

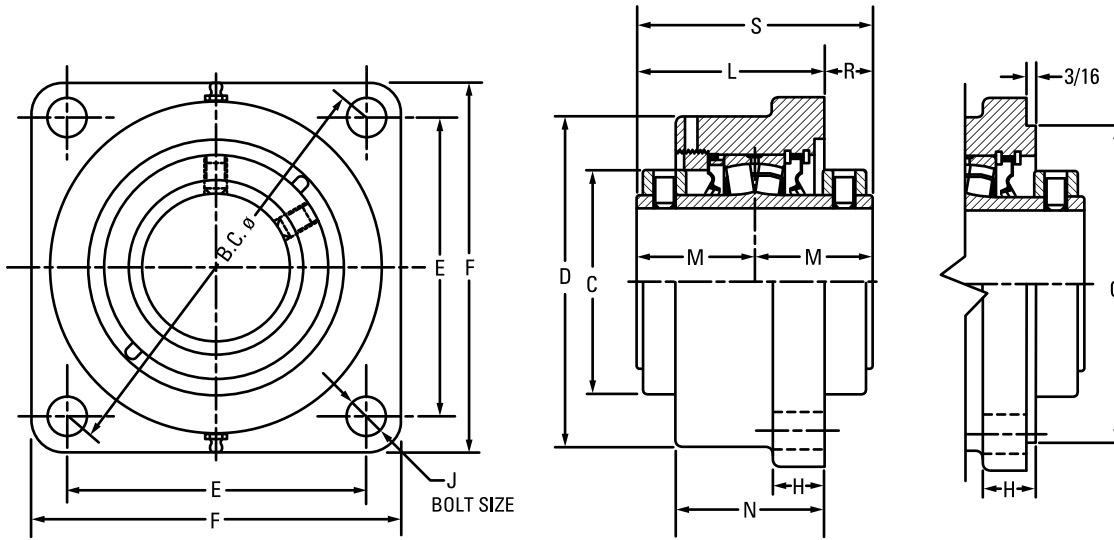

Bearing Part No.	Shaft Dia.	Bearing No.	B.C.	C	D	E	F	G ⁽¹⁾⁽²⁾⁽³⁾	H	J	L _{FIX}	L _{EXP}	M	N	R	S	Wt.
	mm in.		mm in.	mm in.	mm in.	mm in.	mm in.	mm in.	mm in.	mm in.	mm in.	mm in.	mm in.	mm in.	mm in.	mm in.	kg lbs.
QAAFX10A115S	1 15/16 in.	22210	146.1	73.2	120.7	103.1	134.9	111.13	22.4	12	80.8	82.8	47.5	65.0	15.2	95.3	5.4
QAAFX10A200S	2 in.		5.75	2.88	4.75	4.06	5.31	4.375	0.88	1/2	3.18	3.26	1.87	2.56	0.60	3.75	12
QAAFX10A050S	50 mm																
QAAFX11A203S	2 3/16 in.	22211	161.5	82.6	130.3	114.3	149.4	127.00	25.4	16	83.1	85.1	50.5	66.8	18.5	101.6	6.8
QAAFX11A204S	2 1/4 in.		6.36	3.25	5.13	4.50	5.88	5.000	1.00	5/8	3.27	3.35	1.99	2.63	0.73	4.00	15
QAAFX11A055S	55 mm																
QAAFX13A060S	60 mm	22213	180.8	96.8	146.1	127.8	157.2	138.13	25.4	16	89.2	91.2	54.6	72.4	19.6	109.2	8.6
QAAFX13A207S	2 7/16 in.		7.12	3.81	5.75	5.03	6.19	5.438	1.00	5/8	3.51	3.59	2.15	2.85	0.77	4.30	19
QAAFX13A208S	2 1/2 in.																
QAAFX13A065S	65 mm	22215	215.9	109.0	168.9	152.7	189.0	160.35	26.9	20	96.0	98.0	60.2	76.2	24.4	120.4	12.7
QAAFX15A211S	2 11/16 in.		8.50	4.29	6.65	6.01	7.44	6.313	1.06	3/4	3.78	3.86	2.37	3.00	0.96	4.74	28
QAAFX15A212S	2 3/4 in.																
QAAFX15A070S	70 mm	22218	241.3	130.3	193.8	170.7	212.9	187.33	33.3	20	107.2	109.2	65.8	84.1	24.6	131.6	19.1
QAAFX15A215S	2 15/16 in.		9.50	5.13	7.63	6.72	8.38	7.375	1.31	3/4	4.22	4.30	2.59	3.31	0.97	5.18	42
QAAFX15A300S	3 in.																
QAAFX15A075S	75 mm	22220	298.5	152.4	215.9	211.1	268.2	225.43	38.1	24	126.0	128.0	75.4	103.1	24.6	150.4	29.9
QAAFX18A303S	3 3/16 in.		11.75	6.00	8.50	8.31	10.56	8.875	1.50	7/8	4.96	5.04	2.97	4.06	0.97	5.92	66
QAAFX18A304S	3 1/4 in.																
QAAFX18A080S	80 mm	22222	327.2	160.0	256.5	163.6	384.3	263.53	31.8	24	143.8	145.8	94.0	106.9	15.0	158.8	46.3
QAAFX18A085S	85 mm		12.88 ⁽⁴⁾	6.30	10.10	6.44 ⁽⁴⁾	15.13	10.375	1.25	7/8	5.66	5.74	3.70	4.21	0.59	6.25	102
QAAFX18A307S	3 7/16 in.																
QAAFX18A308S	3 1/2 in.	22226	355.6	175.0	284.2	177.8	419.1	284.18	38.1	24	174.8	176.8	94.5	135.1	14.2	189.0	52.2
QAAFX18A090S	90 mm		14.00 ⁽⁴⁾	6.89	11.19	7.00 ⁽⁴⁾	16.50	11.188	1.50	1	6.88	6.96	3.72	5.32	0.56	7.44	115
QAAFX20A315S	3 15/16 in.																
QAAFX20A400S	4 in.																
QAAFX20A100S	100 mm																
QAAFX22A110S	110 mm																
QAAFX22A407S ⁽⁴⁾	4 7/16 in.																
QAAFX22A408S ⁽⁴⁾	4 1/2 in.																
QAAFX22A115S ⁽⁴⁾	115 mm																
QAAFX26A125S ⁽⁴⁾	125 mm																
QAAFX26A415S ⁽⁴⁾	4 15/16 in.																
QAAFX26A500S ⁽⁴⁾	5 in.																
QAAFX26A130S ⁽⁴⁾	130 mm																

⁽¹⁾Pilot tolerance: +0/-0.05 mm (+0/-0.002 in.).

⁽²⁾Add (p) to the end of the housing designation in the part number to order with pilot using G dimension.

⁽³⁾Piloted flange blocks will be quoted (price and delivery) upon request. For optional spigot on flange side, insert the letter P as seen in the following example: QMFP**J***S.

⁽⁴⁾Six-bolt round housing.

QAFY AND QAAFY ROUND FLANGE BLOCKS

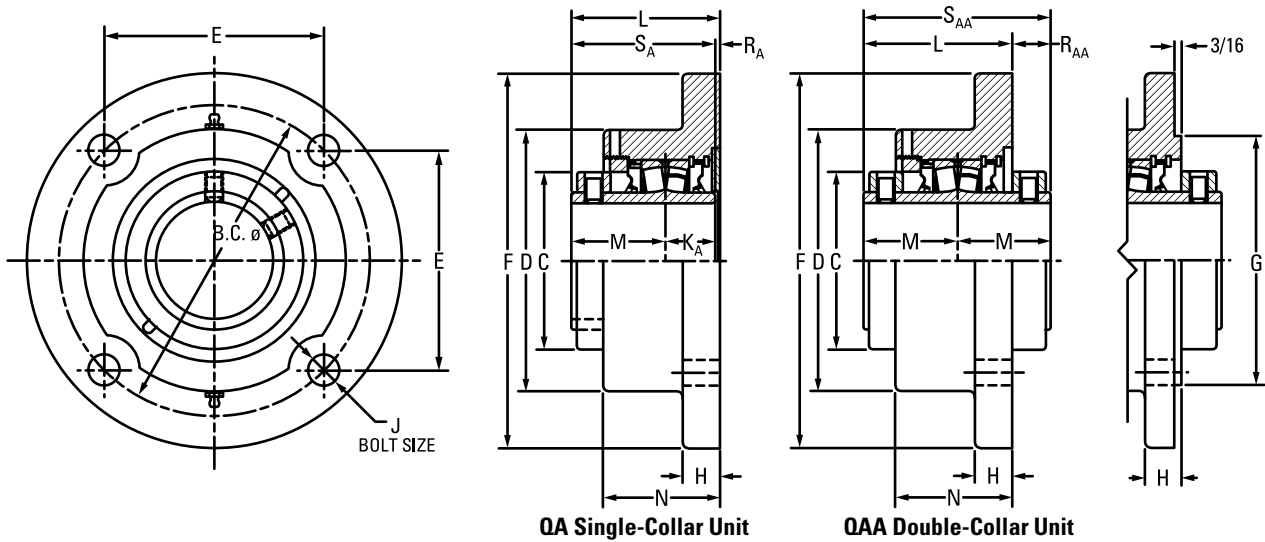

Bearing Part No. ⁽¹⁾	Shaft Dia.	Bearing No.	B.C.	C	D	E	F	G ⁽²⁾⁽³⁾⁽⁴⁾	H	J	KA	L _{FIX}	L _{EXP}	M	N	RA	RAA	SA	SAA	Wt.
	mm in.		mm in.	mm in.	mm in.	mm in.	mm in.	mm in.	mm in.	mm in.	mm in.	mm in.	mm in.	mm in.	mm in.	mm in.	mm in.	mm in.	mm in.	kg lbs.
QAFY08A035S ⁽⁶⁾	35 mm	22208	127.0	60.5	108.0	89.9	158.8	90.50	19.1	12	25.4	73.2	75.2	44.5	57.4	3.3	-	69.9	-	4.5
QAFY08A107S ⁽⁶⁾	1 7/16 in.		5.00	2.38	4.25	3.54	6.25	3.563	0.75	1/2	1.00	2.88	2.96	1.75	2.26	0.13	-	2.75	-	10
QAFY08A108S ⁽⁶⁾	1 1/2 in.																			
QAFY09A040S	40 mm	22209	139.7	66.8	104.9	98.8	171.5	103.20	20.6	12	25.4	76.2	78.2	47.8	60.5	3.0	-	73.2	-	5.0
QAFY09A111S	1 11/16 in.		5.50	2.63	4.13	3.89	6.75	4.063	0.81	1/2	1.00	3.00	3.08	1.88	2.38	0.12	-	2.88	-	11
QAFY09A112S	1 3/4 in.																			
QAFY09A045S	45 mm	22210	146.1	73.2	115.3	103.4	177.8	111.13	19.1	12	25.4	75.9	78.0	47.5	57.2	3.0	20.1	72.9	95.3	5.4
QAFY10A115S	1 15/16 in.		5.75	2.88	4.54	4.07	7.00	4.375	0.75	1/2	1.00	2.99	3.07	1.87	2.25	0.12	0.79	2.87	3.75	12
QAAFY10A200S	2 in.																			
QAFY10A050S	50 mm	22211	162.1	82.6	130.3	114.3	196.9	127.00	19.1	16	28.7	82.3	84.3	50.8	62.0	3.0	19.3	79.5	101.6	6.8
QAAFY10A050S			6.38	3.25	5.13	4.50	7.75	5.000	0.75	5/8	1.13	3.24	3.32	2.00	2.44	0.12	0.76	3.13	4.00	15
QAFY11A203S	2 3/16 in.																			
QAFY11A204S	2 1/4 in.																			
QAAFY11A203S																				
QAFY11A055S	55 mm	22213	171.5	96.8	146.1	121.2	206.5	138.13	23.9	16	31.5	91.2	93.2	54.6	72.4	5.1	20.6	86.1	109.2	8.6
QAAFY11A055S			6.75	3.81	5.75	4.77	8.13	5.438	0.94	5/8	1.24	3.59	3.67	2.15	2.85	0.20	0.81	3.39	4.30	19
QAFY13A060S	60 mm																			
QAFY13A207S	2 7/16 in.																			
QAAFY13A207S																				
QAFY13A208S	2 1/2 in.																			
QAAFY13A208S																				
QAFY13A065S	65 mm																			
QAAFY13A065S																				

⁽¹⁾Bearing part numbers use QA to designate single-collar units (use SA and RA dimensions) and QAA to designate double-collar units (use SAA and RAA dimensions).

Continued on next page.

⁽²⁾Pilot tolerance: +0/-0.05 mm (+0/-0.002 in.).

⁽³⁾Add (p) to the end of the housing designation in the part number to order with pilot using G dimension.

⁽⁴⁾Piloted flange blocks will be quoted (price and delivery) upon request. For optional spigot on flange side, insert the letter P as seen in the following example: QMFPP**J***S.

⁽⁵⁾Six-bolt housing.

⁽⁶⁾Three-bolt housing.

**QAFY AND QAAFY
ROUND FLANGE
BLOCKS – continued**

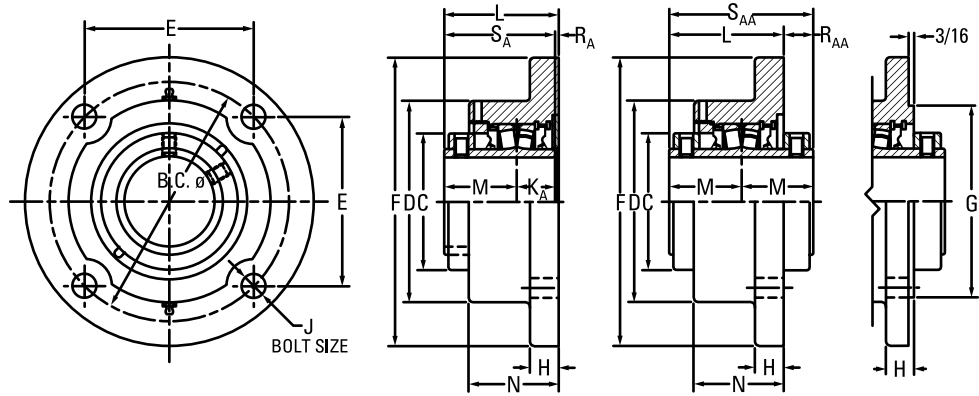

QA Single-Collar Unit QAA Double-Collar Unit

Continued from previous page.

Bearing Part No. ⁽¹⁾	Shaft Dia.	Bearing No.	B.C.	C	D	E	F	G ⁽²⁾⁽³⁾⁽⁴⁾	H	J	K _A	L _{FIX}	L _{EXP}	M	N	R _A	R _{AA}	S _A	S _{AA}	Wt.	
	mm in.		mm in.	mm in.	mm in.	mm in.	mm in.	mm in.	mm in.	mm in.	mm in.	mm in.	mm in.	mm in.	mm in.	mm in.	mm in.	mm in.	mm in.	mm in.	kg lbs.
QAFY15A211S QAAFY15A211S	2 11/16 in.	22215	200.2 7.88	109.0 4.29	168.4 6.63	141.5 5.57	241.3 9.50	160.35 6.313	23.9 0.94	20 3/4	31.8 1.25	98.3 3.87	100.3 3.95	60.2 2.37	74.4 2.93	6.4 0.25	21.8 0.86	91.9 3.62	120.4 4.74	12.7 28	
QAFY15A212S QAAFY15A212S	2 3/4 in.																				
QAFY15A070S QAAFY15A070S	70 mm																				
QAFY15A215S QAAFY15A215S	2 15/16 in.																				
QAFY15A300S QAAFY15A300S	3 in.																				
QAFY15A075S QAAFY15A075S	75 mm																				
QAFY18A303S QAAFY18A303S	3 3/16 in.	22218	241.3 9.50	130.3 5.13	193.8 7.63	170.7 6.72	282.7 11.13	N/A	28.7 1.13	24 7/8	36.6 1.44	108.7 4.28	110.7 4.36	65.8 2.59	85.3 3.36	6.4 0.25	22.9 0.90	102.4 4.03	131.6 5.18	19.1 42	
QAFY18A304S QAAFY18A304S	3 1/4 in.																				
QAFY18A080S QAAFY18A080S	80 mm																				
QAFY18A085S QAAFY18A085S	85 mm																				
QAFY18A307S QAAFY18A307S	3 7/16 in.																				
QAFY18A308S QAAFY18A308S	3 1/2 in.																				
QAFY18A090S QAAFY18A090S	90 mm	22220	273.1 10.75	152.4 6.00	212.9 8.38	193.0 7.60	320.8 12.63	N/A	28.7 1.13	24 1	41.4 1.63	123.7 4.87	125.7 4.95	75.4 2.97	96.8 3.81	6.9 0.27	26.7 1.05	116.6 4.59	150.4 5.92	29.9 66	
QAFY20A315S QAAFY20A315S	3 15/16 in.																				
QAFY20A400S QAAFY20A400S	4 in.																				
QAFY20A100S QAAFY20A100S	100 mm																				
QAAFY22A110S ⁽⁵⁾	110 mm																				
QAAFY22A407S ⁽⁵⁾	4 7/16 in.																				
QAAFY22A408S ⁽⁵⁾	4 1/2 in.	22222	327.2 12.88 ⁽⁵⁾	160.0 6.30	254.0 10.00	163.6 6.44 ⁽⁵⁾	384.3 15.13	N/A	31.8 1.25	24 1 ⁽⁵⁾	-	129.0 5.08	131.1 5.16	79.5 3.13	100.3 3.95	-	30.0 1.18	-	158.8 6.25	46.3 102	
QAAFY22A115S ⁽⁵⁾	115 mm																				
QAAFY26A125S ⁽⁵⁾	125 mm	22226	355.6 14.00 ⁽⁵⁾	175.0 6.89	284.2 11.19	177.8 7.00 ⁽⁵⁾	419.1 16.50	N/A	38.1 1.50	27 1 1/8 ⁽⁵⁾	-	169.9 6.69	172.0 6.77	94.5 3.72	139.7 5.50	-	19.1 0.75	-	189.0 7.44	52.2 115	
QAAFY26A415S ⁽⁵⁾	4 15/16 in.																				
QAAFY26A500S ⁽⁵⁾	5 in.																				
QAAFY26A130S ⁽⁵⁾	130 mm																				

⁽¹⁾ Bearing part numbers use QA to designate single-collar units (use S_A and R_A dimensions) and QAA to designate double-collar units (use S_{AA} and R_{AA} dimensions).

⁽²⁾ Pilot tolerance: +0/-0.05 mm (+0/-0.002 in.).

⁽³⁾ Add (p) to the end of the housing designation in the part number to order with pilot using G dimension.

⁽⁴⁾ Piloted flange blocks will be quoted (price and delivery) upon request. For optional spigot on flange side, insert the letter P as seen in the following example: QMFP**J***S.

⁽⁵⁾ Six-bolt housing.

⁽⁶⁾ Three-bolt housing.

QAMC AND QAAMC CARTRIDGE BLOCKS

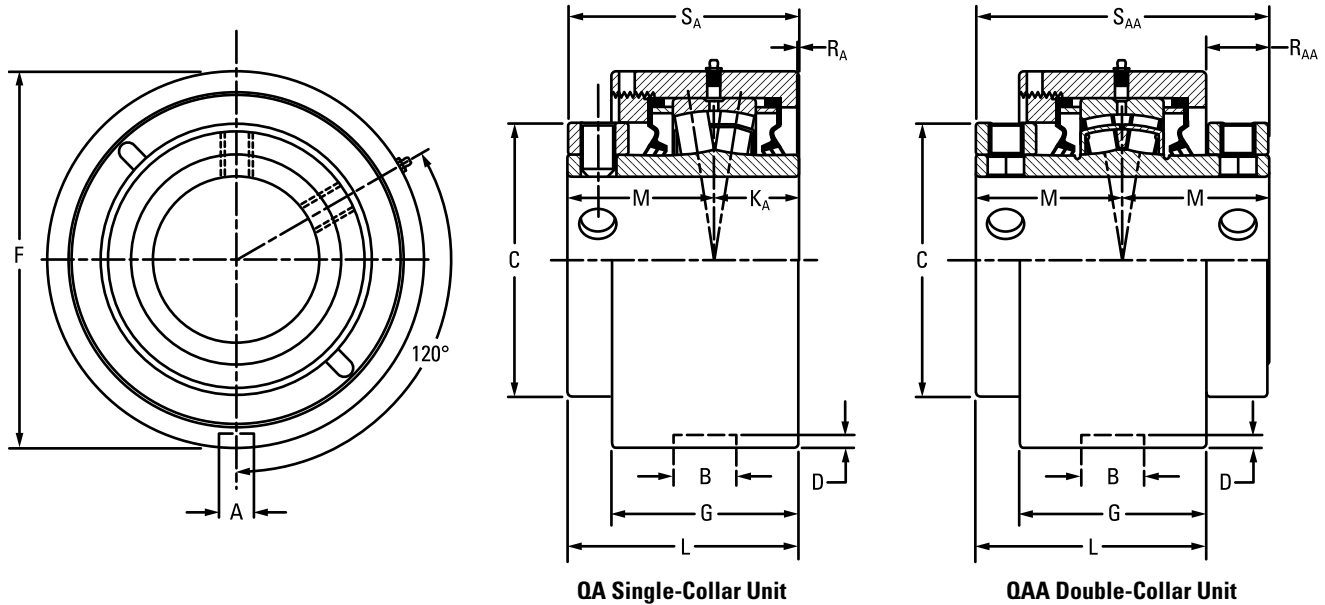

QA Single-Collar Unit

QAA Double-Collar Unit

Bearing Part No. ⁽¹⁾	Shaft Dia.	Bearing No.	A	B	C	D	F	G	KA	L FIX	L EXP	M	RA	RAA	SA	SAA	Wt.
	mm in.		mm in.	mm in.	mm in.	mm in.	mm in.	mm in.	mm in.	mm in.	mm in.	mm in.	mm in.	mm in.	mm in.	mm in.	kg lbs.
QAMC10A115S QAAMC10A115S	1 15/16 in.	22210	13.5 0.53	23.1 0.91	73.2 2.88	4.8 0.19	104.78 (+0/-0.05) 4.125 (+0/-0.002)	62.2 2.45	25.4 1.00	79.2 3.12	81.3 3.20	47.5 1.87	6.1 0.24	16.8 0.66	72.9 2.87	95.3 3.75	3.6 8
QAMC10A200S QAAMC10A200S	2 in.																
QAMC10A050S QAAMC10A050S	50 mm																
QAMC11A203S QAAMC11A203S	2 3/16 in.	22211	13.5 0.53	23.1 0.91	82.6 3.25	4.8 0.19	115.09 (+0/-0.05) 4.531 (+0/-0.002)	65.5 2.58	28.7 1.13	83.8 3.30	85.9 3.38	50.8 2.00	4.1 0.16	18.0 0.71	79.5 3.13	101.6 4.00	4.5 10
QAMC11A204S QAAMC11A204S	2 1/4 in.																
QAMC11A055S QAAMC11A055S	55 mm																
QAMC13A060S QAAMC13A060S	60 mm	22213	13.5 0.53	23.1 0.91	96.8 3.81	3.6 0.14	127.00 (+0/-0.05) 5.000 (+0/-0.002)	69.3 2.73	31.5 1.24	85.9 3.38	87.9 3.46	54.6 2.15	0.0 0.00	14.0 0.55	86.1 3.39	109.2 4.30	5.4 12
QAMC13A207S QAAMC13A207S	2 7/16 in.																
QAMC13A208S QAAMC13A208S	2 1/2 in.																
QAMC13A065S QAAMC13A065S	65 mm	22215	15.0 0.59	26.2 1.03	109.0 4.29	6.4 0.25	149.225 (+0/-0.05) 5.875 (+0/-0.002)	79.8 3.14	31.8 1.25	100.6 3.96	102.6 4.04	60.2 2.37	8.1 0.32	19.8 0.78	91.9 3.62	120.4 4.74	8.2 18
QAMC15A211S QAAMC15A211S	2 11/16 in.																
QAMC15A212S QAAMC15A212S	2 3/4 in.																
QAMC15A070S QAAMC15A070S	70 mm																
QAMC15A215S QAAMC15A215S	2 15/16 in.																
QAMC15A300S QAAMC15A300S	3 in.																
QAMC15A075S QAAMC15A075S	75 mm																

⁽¹⁾Bearing part numbers use QA to designate single-collar units (use SA and RA dimensions) and QAA to designate double-collar units (use SAA and RAA dimensions).

Continued on next page.

QAMC AND QAAMC CARTRIDGE BLOCKS – continued

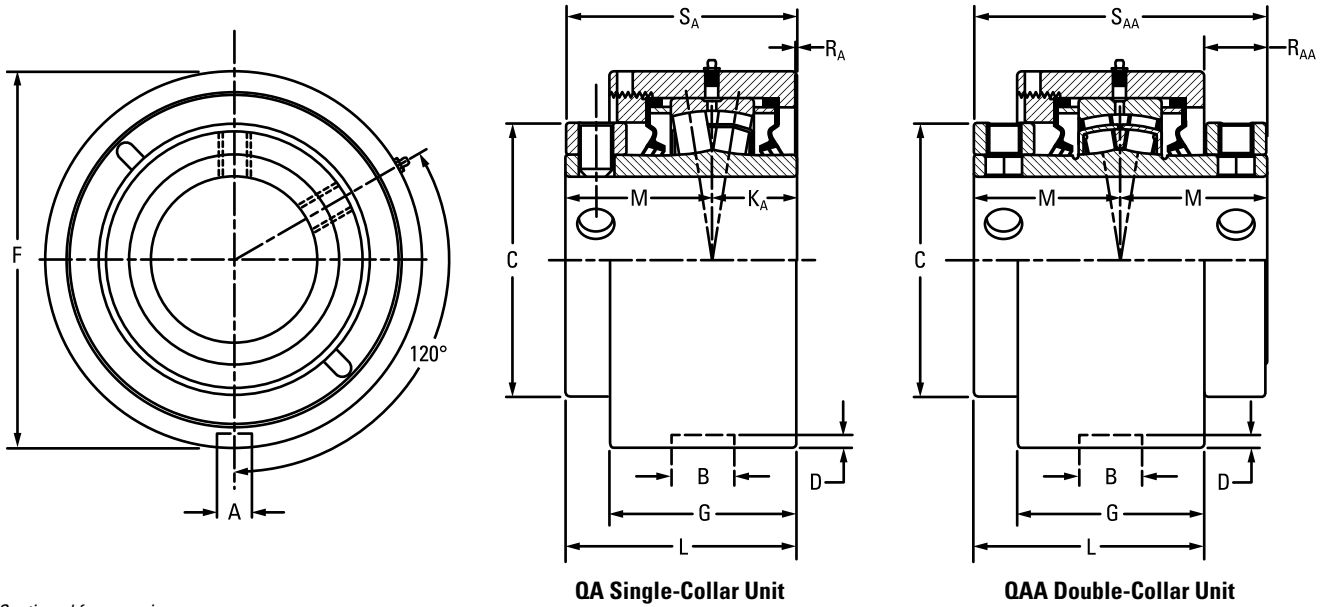

Continued from previous page.

Bearing Part No. ⁽¹⁾	Shaft Dia.	Bearing No.	A	B	C	D	F	G	K _A	L _{FIX}	L _{EXP}	M	R _A	R _{AA}	S _A	S _{AA}	Wt.																
	mm in.		mm in.	mm in.	mm in.	mm in.	mm in.	mm in.	mm in.	mm in.	mm in.	mm in.	mm in.	mm in.	mm in.	mm in.	kg lbs.																
QAMC18A303S QAAMC18A303S	3 3/16 in.	22218	15.0 0.59	26.9 1.06	130.3 5.13	5.8 0.23	171.45 (+0/-0.05) 6.750 (+0/-0.002)	87.6 3.45	36.6 1.44	110.2 4.34	112.3 4.42	65.8 2.59	7.4 0.29	21.3 0.84	102.4 4.03	131.6 5.18	11.8 26																
QAMC18A304S QAAMC18A304S	3 1/4 in.																																
QAMC18A080S QAAMC18A080S	80 mm																																
QAMC18A085S QAAMC18A085S	85 mm																																
QAMC18A307S QAAMC18A307S	3 7/16 in.																																
QAMC18A308S QAAMC18A308S	3 1/2 in.																																
QAMC18A090S QAAMC18A090S	90 mm																																
QAMC20A315S QAAMC20A315S	3 15/16 in.																	22220	19.8 0.78	32.5 1.28	152.4 6.00	7.9 0.31	206.375 (+0/-0.05) 8.125 (+0/-0.002)	105.2 4.14	41.4 1.63	128.3 5.05	130.3 5.13	75.4 2.97	11.4 0.45	22.6 0.89	116.6 4.59	150.9 5.94	14.5 32
QAMC20A400S QAAMC20A400S	4 in.																																
QAMC20A100S QAAMC20A100S	100 mm																																
QAAMC22A110S	110 mm																																
QAAMC22A407S	4 7/16 in.	22222	19.8 0.78	38.1 1.50	160.0 6.30	7.9 0.31	222.25 (+0/-0.08) 8.75 (+0/-0.003)	108.5 4.27	-	133.6 5.26	135.6 5.34	79.5 3.13	-	25.1 0.99	-	158.8 6.25	18.1 40																
QAAMC22A408S	4 1/2 in.																																
QAAMC22A115	115 mm																																
QAAMC26A125S	125 mm	22226	19.8 0.78	38.1 1.50	175.0 6.89	7.9 0.31	265.13 (+0/-0.08) 10.438 (+0/-0.003)	141.7 5.58	-	165.4 6.51	167.4 6.59	94.5 3.72	-	23.6 0.93	-	189.0 7.44	18.1 40																
QAAMC26A415S	4 15/16 in.																																
QAAMC26A500S	5 in.																																
QAAMC26A130S	130 mm																																

⁽¹⁾Bearing part numbers use QA to designate single-collar units (use S_A and R_A dimensions) and QAA to designate double-collar units (use S_{AA} and R_{AA} dimensions).

QATU AND QAATU TAKE-UP BLOCKS

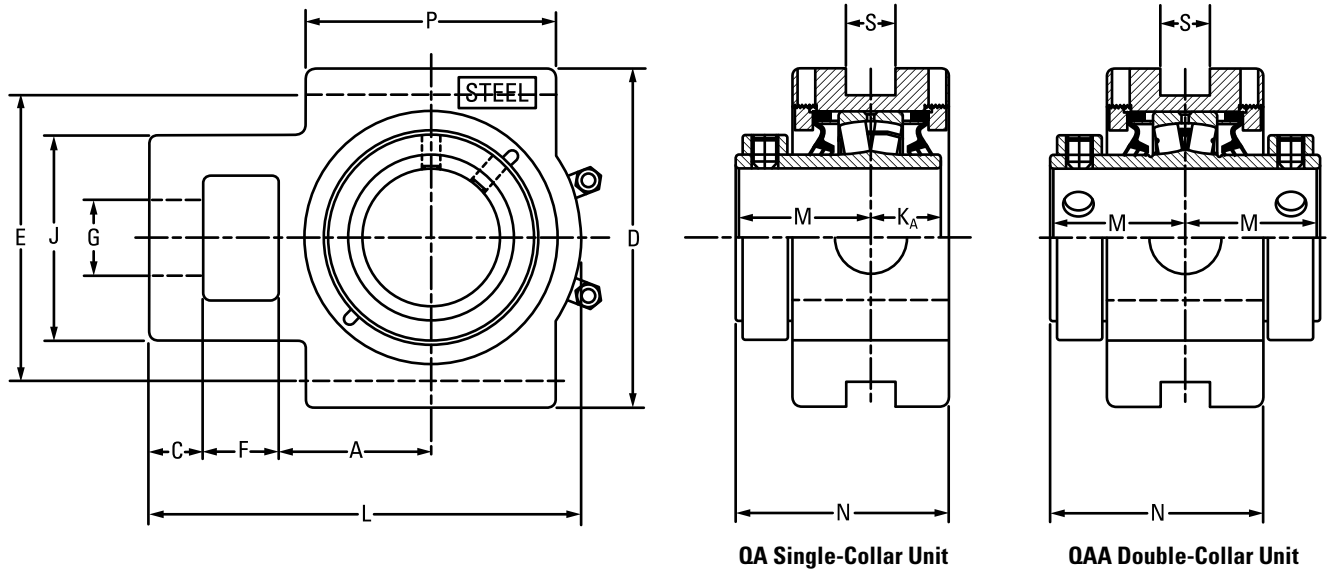

Bearing Part No. ⁽¹⁾	Shaft Dia.	Bearing No.	A	C	D	E	F	G	J	K _A	L	M	N	P	S	Wt.
	mm in.		mm in.	mm in.	mm in.	mm in.	mm in.	mm in.	mm in.	mm in.	mm in.	mm in.	mm in.	mm in.	mm in.	kg lbs.
QATU10A115S QAATU10A115S	1 15/16 in.	22210	54.1 2.13	19.1 0.75	120.7 4.75	101.6 4.00	26.9 1.06	26.9 1.06	73.2 2.88	25.4 1.00	153.4 6.04	47.5 1.87	75.7 2.98	88.9 3.50	17.5 0.69	7.7 17
QATU10A200S QAATU10A200S	2 in.															
QATU10A050S QAATU10A050S	50 mm															
QATU11A203S QAATU11A203S	2 3/16 in.	22211	60.5 2.38	19.1 0.75	133.4 5.25	114.3 4.50	28.7 1.13	30.2 1.19	88.9 3.50	28.7 1.13	167.9 6.61	50.8 2.00	81.8 3.22	95.3 3.75	20.6 0.81	9.5 21
QATU11A204S QAATU11A204S	2 1/4 in.															
QATU11A055S QAATU11A055S	55 mm															
QATU13A060S QAATU13A060S	60 mm	22213	69.9 2.75	22.4 0.88	149.4 5.88	130.3 5.13	33.3 1.31	33.3 1.31	95.3 3.75	31.5 1.24	193.8 7.63	54.6 2.15	91.2 3.59	120.7 4.75	26.9 1.06	12.2 27
QATU13A207S QAATU13A207S	2 7/16 in.															
QATU13A208S QAATU13A208S	2 1/2 in.															
QATU13A065S QAATU13A065S	65 mm	22215	76.2 3.00	25.4 1.00	171.5 6.75	150.9 5.94	39.6 1.56	39.6 1.56	108.0 4.25	31.8 1.25	219.7 8.65	60.2 2.37	97.0 3.82	120.7 4.75	46.0 1.81	15.9 35
QATU15A211S QAATU15A211S	2 11/16 in.															
QATU15A212S QAATU15A212S	2 3/4 in.															
QATU15A070S QAATU15A070S	70 mm	22215	76.2 3.00	25.4 1.00	171.5 6.75	150.9 5.94	39.6 1.56	39.6 1.56	108.0 4.25	31.8 1.25	219.7 8.65	60.2 2.37	97.0 3.82	120.7 4.75	46.0 1.81	15.9 35
QATU15A215S QAATU15A215S	2 15/16 in.															
QATU15A300S QAATU15A300S	3 in.															
QATU15A075S QAATU15A075S	75 mm															

⁽¹⁾Bearing part numbers use QA to designate single-collar units and QAA to designate double-collar units.
NOTE: Please refer to page 177 for take-up frames.

Continued on next page.

QATU AND QAATU TAKE-UP BLOCKS – continued

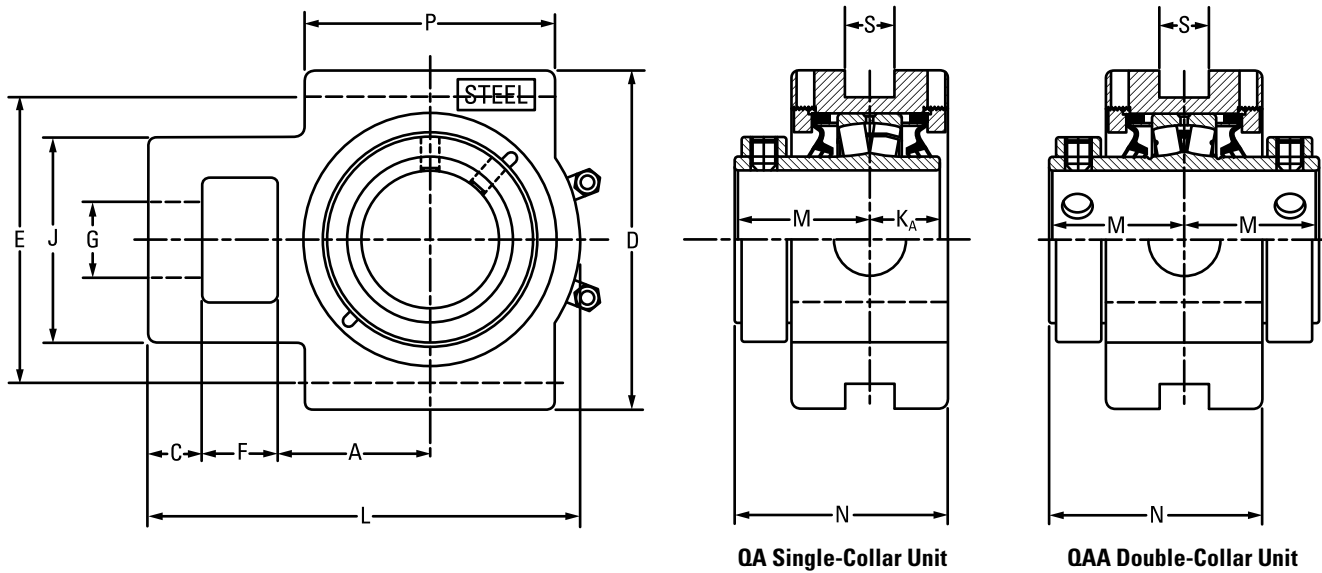

Continued from previous page.

Bearing Part No. ⁽¹⁾	Shaft Dia.	Bearing No.	A	C	D	E	F	G	J	K _A	L	M	N	P	S	Wt.
	mm in.		mm in.	mm in.	mm in.	mm in.	mm in.	mm in.	mm in.	mm in.	mm in.	mm in.	mm in.	mm in.	mm in.	kg lbs.
QATU18A303S QAATU18A303S	3 3/16 in.	22218	92.2 3.63	25.4 1.00	193.8 7.63	173.0 6.81	46.0 1.81	47.8 1.88	124.0 4.88	36.6 1.44	257.0 10.12	65.8 2.59	107.2 4.22	158.8 6.25	46.0 1.81	20.0 44
QATU18A304S QAATU18A304S	3 1/4 in.															
QATU18A080S QAATU18A080S	80 mm															
QATU18A085S QAATU18A085S	85 mm															
QATU18A307S QAATU18A307S	3 7/16 in.															
QATU18A308S QAATU18A308S	3 1/2 in.															
QATU18A090S QAATU18A090S	90 mm															
QATU20A315S QAATU20A315S	3 15/16 in.															
QATU20A400S QAATU20A400S	4 in.															
QATU20A100S QAATU20A100S	100 mm															
QAATU22A110S	110 mm	22222	128.5 5.06	38.1 1.50	263.7 10.38	241.3 9.50	54.1 2.13	54.1 2.13	162.1 6.38	-	341.4 13.44	79.5 3.13	143.8 5.66	199.9 7.87	52.3 2.06	36.4 80
QAATU22A407S	4 7/16 in.															
QAATU22A408S	4 1/2 in.															
QAATU22A115S	115 mm	22226	134.9 5.31	63.5 2.50	285.8 11.25	260.4 10.25	63.5 2.50	60.5 2.38	177.8 7.00	-	396.7 15.62	94.5 3.72	150.9 5.94	228.6 9.00	52.3 2.06	60.8 134
QAATU26A125S	125 mm															
QAATU26A415S	4 15/16 in.															
QAATU26A500S	5 in.															
QAATU26A130S	130 mm															

⁽¹⁾Bearing part numbers use QA to designate single-collar units and QAA to designate double-collar units.
NOTE: Please refer to page 177 for take-up frames.

QAMH AND QAAMH HANGER BLOCKS

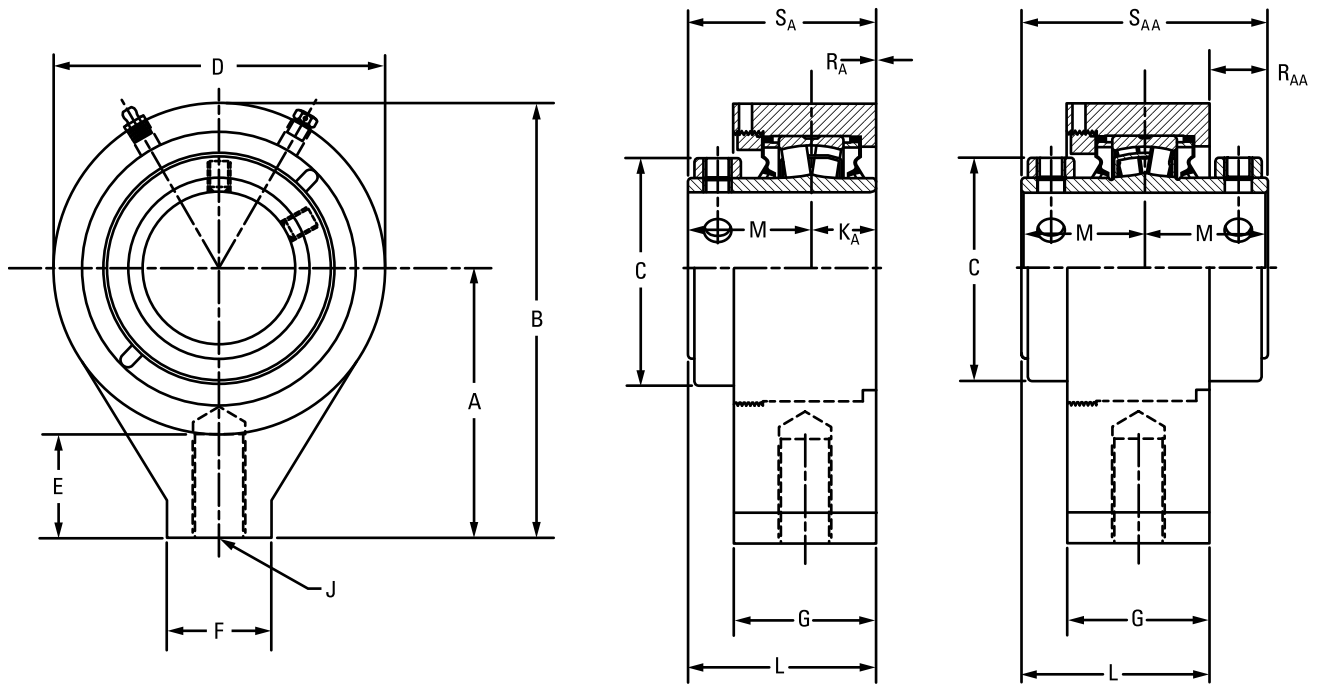

Bearing Part No.	Shaft Dia.	Bearing No.	A	B	C	D	E	F	G	J	KA	L	M	RA	RAA	SA	SAA	Wt.
	mm in.		mm in.	mm in.	mm in.	mm in.	mm in.	mm in.	mm in.	in.	mm in.	mm in.	mm in.	mm in.	mm in.	mm in.	mm in.	kg lbs.
QAMH15A211S QAAMH15A211S	2 1/16 in.	22215	131.8 5.19	212.9 8.38	109.0 4.29	162.1 6.38	50.8 2.00	50.8 2.00	69.9 2.75	1 - 8UNC	31.8 1.25	91.9 3.62	60.2 2.37	0.0 0.00	28.4 1.12	91.9 3.62	120.7 4.75	10.0 22
QAMH15A212S QAAMH15A212S	2 3/4 in.																	
QAMH15A070S QAAMH15A070S	70 mm																	
QAMH15A215S QAAMH15A215S	2 15/16 in.																	
QAMH15A300S QAAMH15A300S	3 in.																	
QAMH15A075S QAAMH15A075S	75 mm																	
QAMH18A303S QAAMH18A303S	3 3/16 in.																	
QAMH18A304S QAAMH18A304S	3 1/4 in.																	
QAMH18A080S QAAMH18A080S	80 mm																	
QAMH18A085S QAAMH18A085S	85 mm																	
QAMH18A307S QAAMH18A307S	3 7/16 in.																	
QAMH18A308S QAAMH18A308S	3 1/2 in.																	
QAMH18A090S QAAMH18A090S	90 mm																	

EC SERIES

The reduced eccentric offset of our EC series locking collar results in a secure shaft lock that is designed not to release from a properly prepared shaft. EC series housed units also are suitable for reversing applications.



Fig. 47. EC series eccentric lock.

YOU HAVE CHOICES

For the EC series, you can select from many seal configurations and housing styles, which are shown on page 65.

HOUSINGS

- Two-bolt pillow blocks.
- Four-bolt pillow blocks.
- Flange blocks.
- Piloted flange cartridges.
- Take-up blocks.
- Cartridge blocks.
- Hanger blocks.

SEALS

- Labyrinth: DuPont Teflon (T).
- Triple-lip: nitrile rubber (M), urethane (O) and DuPont Viton (N).
- Double-lip: nitrile rubber (B) and DuPont Viton (C).
- Steel and urethane closed-end covers (CS).
- Steel and urethane open-end covers (CJ) with:
 - DuPont Teflon (T).
 - Triple-lip seal (DR).
 - V-ring seal (VR).
- Piloted flange cartridge backing plates (HSY) with:
 - Triple-lip seal (DR).
- Flange block backing plates (UFP).
 - V-ring (VR).

EC SERIES

	Housing Type	Primary Seals						Secondary Seals and Covers					
		M	N	O	B	C	T	Open-End Cover			Closed-End Cover	HSY Flange Cartridge Backing Plate	UFP Backing Plate
								DR	VR	T		DR	
V-Lock (Timken Exclusive Double Taper Lock)	Pillow Block	•	•	•	•	•	•	•	•	•	•		
	Flange Block	•	•	•	•	•	•	•	•	•	•		
	Piloted Flange Cartridge	•	•	•	•	•	•	•	•	•	•		
	Take-Up Block	•	•	•	•	•	•	•	•	•	•		
	Cartridge Block	•	•	•	•	•	•	•	•	•	•		
CL Series (Set Screw Lock)	Pillow Block	•	•	•	•	•	•	•	•	•	•		
	Flange Block	•	•	•	•	•	•	•	•	•	•		•
	Piloted Flange Cartridge	•	•	•	•	•	•	•	•	•	•	•	
	Take-Up Block	•	•	•	•	•	•	•	•	•	•		
	Cartridge Block	•	•	•	•	•	•	•	•	•	•		
	Hanger Block	•	•	•	•	•	•	•	•	•	•		
EC Series (Eccentric Lock)	Pillow Block	•	•	•	•	•	•	•	•	•	•		
	Flange Block	•	•	•	•	•	•	•	•	•	•		•
	Piloted Flange Cartridge	•	•	•	•	•	•	•	•	•	•	•	
	Take-Up Block	•	•	•	•	•	•	•	•	•	•		
	Cartridge Block	•	•	•	•	•	•	•	•	•	•		
	Hanger Block	•	•	•	•	•	•	•	•	•	•		
TA Series (Tapered Adapter Lock)	Pillow Block	•	•	•	•	•	•	•	•	•	•		
	Flange Block	•	•	•	•	•	•	•	•	•	•		
	Piloted Flange Cartridge	•	•	•	•	•	•	•	•	•	•		
	Cartridge Block	•	•	•	•	•	•	•	•	•	•		
DV Series (Tapered Adapter Lock)	Pillow Block	•	•	•	•	•	•	•	•	•	•		
	Flange Block	•	•	•	•	•	•	•	•	•	•		
	Piloted Flange Cartridge	•	•	•	•	•	•	•	•	•	•		

QMP TWO-BOLT PILLOW BLOCKS

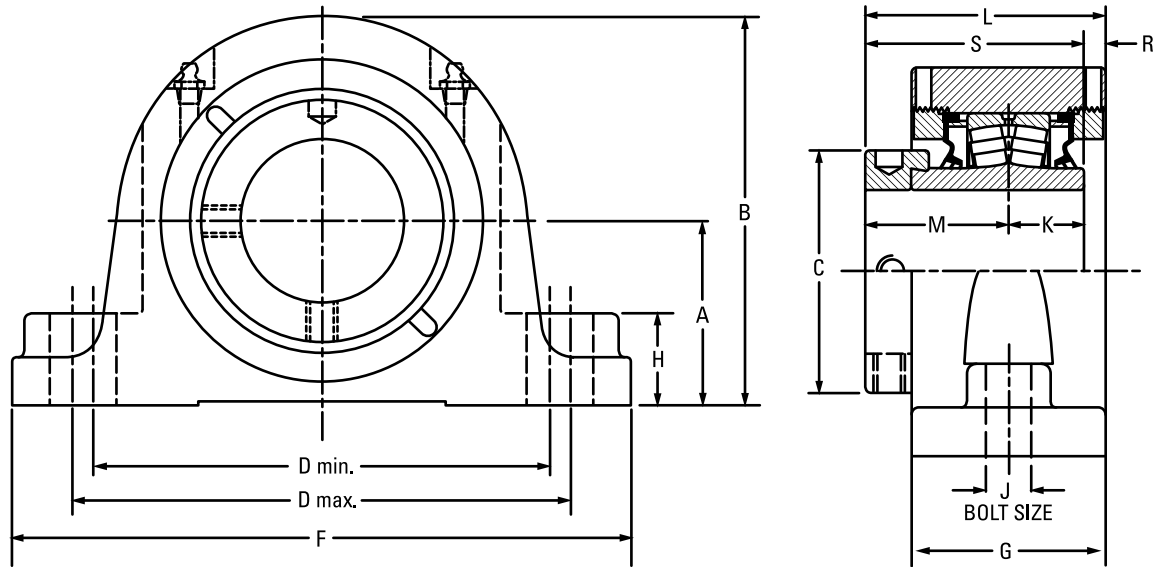

Bearing Part No.	Shaft Dia.	Bearing No.	A	B	C	D min.	D max.	F	G	H	J	K	L	M	R	S	Wt.	
	mm in.		mm in.	mm in.	mm in.	mm in.	mm in.	mm in.	mm in.	mm in.	mm in.	mm in.	mm in.	mm in.	mm in.	mm in.	kg lbs.	
QMP08J035S	35 mm	22208	47.8	94.7	60.5	119.1	152.4	174.8	57.2	25.4	12	25.4	73.2	44.5	3.3	69.9	4.1	
QMP08J107S	1 7/16 in.		1.88	3.73	2.38	4.69	6.00	6.88	2.25	1.00	1/2	1.00	2.88	1.75	0.13	2.75	9	
QMP08J108S	1 1/2 in.	22208	54.1	101.1	60.5	119.1	165.1	200.2	57.2	25.4	12	25.4	73.2	44.5	3.3	69.9	4.1	
			2.13	3.98	2.38	4.69	6.50	7.88	2.25	1.00	1/2	1.00	2.88	1.75	0.13	2.75	9	
QMP09J111S	1 11/16 in.	22209	54.1	104.9	66.5	144.8	165.1	200.2	60.2	31.8	12	25.4	77.7	47.8	4.8	73.2	4.5	
			2.13	4.13	2.62	5.70	6.50	7.88	2.37	1.25	1/2	1.00	3.06	1.88	0.19	2.88	10	
QMP09J040S	40 mm	22209	57.2	108.0	66.5	158.8	180.8	225.6	62.0	31.8	16	25.4	78.7	47.8	5.8	73.2	4.5	
QMP09J112S	1 3/4 in.		2.25	4.25	2.62	6.25	7.12	8.88	2.44	1.25	5/8	1.00	3.10	1.88	0.23	2.88	10	
QMP09J045S	45 mm																	
QMP10J115S	1 15/16 in.	22210	57.2	122.2	71.4	152.4	181.1	225.6	62.0	31.8	16	25.4	79.0	47.5	6.1	72.9	5.9	
QMP10J200S	2 in.		2.25	4.81	2.81	6.00	7.13	8.88	2.44	1.25	5/8	1.00	3.11	1.87	0.24	2.87	13	
QMP10J050S	50 mm																	
QMP11J203S	2 3/16 in.	22211	63.5	133.4	75.9	165.1	200.2	244.6	66.8	31.8	16	28.7	84.1	50.8	4.8	79.5	7.7	
QMP11J204S	2 1/4 in.		2.50	5.25	2.99	6.50	7.88	9.63	2.63	1.25	5/8	1.13	3.31	2.00	0.19	3.13	17	
QMP11J055S	55 mm																	
QMP13J060S	60 mm	22213	69.9	147.3	91.9	174.8	219.2	260.4	73.7	35.1	16	31.5	91.2	54.1	5.3	85.6	10.0	
QMP13J207S	2 7/16 in.		2.75	5.80	3.62	6.88	8.63	10.25	2.90	1.38	5/8	1.24	3.59	2.13	0.21	3.37	22	
QMP13J208S	2 1/2 in.																	
QMP13J065S	65 mm																	
QMP15J211S	2 11/16 in.	22215	79.5	164.3	101.9	200.2	244.6	295.4	76.2	35.1	20	31.8	98.3	60.2	6.4	91.9	12.7	
QMP15J212S	2 3/4 in.		3.13	6.47	4.01	7.88	9.63	11.63	3.00	1.38	3/4	1.25	3.87	2.37	0.25	3.62	28	
QMP15J070S	70 mm																	
QMP15J215S	2 15/16 in.																	
QMP15J300S	3 in.																	
QMP15J075S	75 mm																	
QMP18J303S	3 3/16 in.	22218	95.3	195.3	120.9	238.3	285.8	342.9	86.6	47.8	24	36.6	109.2	65.8	7.1	102.4	20.4	
QMP18J304S	3 1/4 in.		3.75	7.69	4.76	9.38	11.25	13.50	3.41	1.88	7/8	1.44	4.30	2.59	0.28	4.03	45	
QMP18J080S	80 mm																	
QMP18J085S	85 mm																	
QMP18J307S	3 7/16 in.																	
QMP18J308S	3 1/2 in.																	
QMP18J090S	90 mm																	
QMP20J311S	3 11/16 in.	22220	104.9	209.8	152.4	255.0	320.0	362.0	94.7	50.8	24	41.4	122.9	75.2	6.1	116.6	26.8	
QMP20J312S	3 3/4 in.		4.13	8.26	6.00	10.04	12.60	14.25	3.73	2.00	1	1.63	4.84	2.96	0.24	4.59	59	
QMP20J315S	3 15/16 in.																	
QMP20J400S	4 in.																	
QMP20J100S	100 mm																	

QMPL TWO-BOLT PILLOW BLOCKS

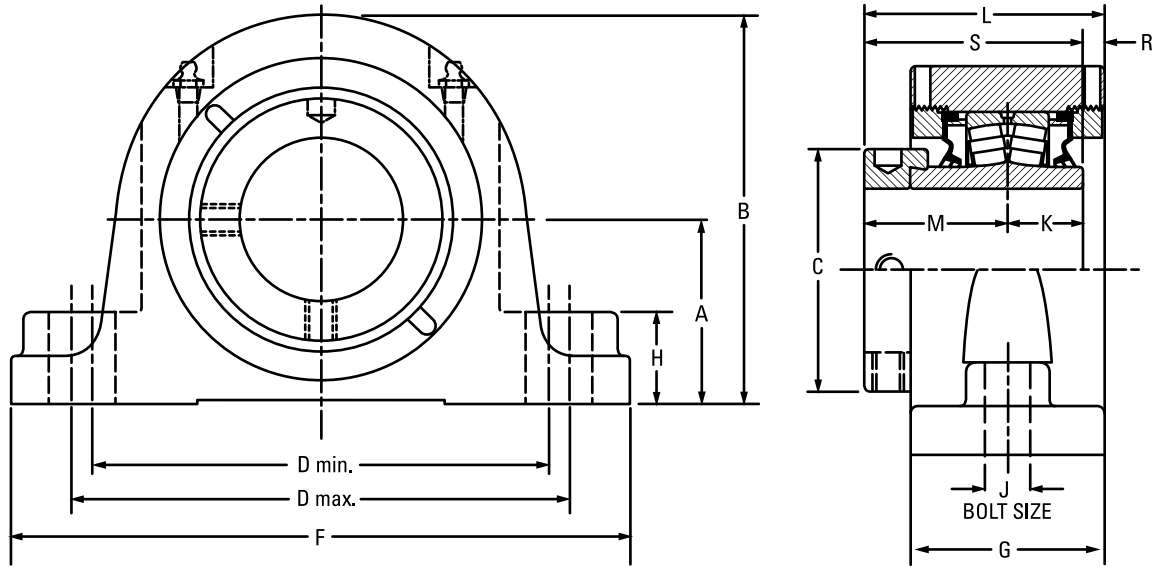

Bearing Part No.	Shaft Dia.	Bearing No.	A	B	C	D min.	D max.	F	G	H	J	K	L	M	R	S	Wt.	
			mm in.	mm in.	mm in.	mm in.	mm in.	mm in.	mm in.	mm in.	mm in.	mm in.	mm in.	mm in.	mm in.	mm in.	mm in.	mm in.
QMPL08J035S	35 mm	22208	47.8	94.7	60.5	119.1	152.4	174.8	57.2	25.4	12	25.4	73.2	44.5	3.3	69.9	4.1	
QMPL08J107S	1 7/16 in.		1.88	3.73	2.38	4.69	6.00	6.88	2.25	1.00	1/2	1.00	2.88	1.75	0.13	2.75	9	
QMPL08J108S	1 1/2 in.																	
QMPL09J040S	40 mm	22209	54.1	104.9	66.5	133.4	146.1	181.1	60.2	31.8	12	25.4	77.7	47.8	4.8	73.2	4.5	
QMPL09J111S	1 11/16 in.		2.13	4.13	2.62	5.25	5.75	7.13	2.37	1.25	1/2	1.00	3.06	1.88	0.19	2.88	10	
QMPL09J112S	1 3/4 in.																	
QMPL09J045S	45 mm	22210	57.2	122.2	71.4	150.6	161.5	212.9	62.0	31.8	16	25.4	79.0	47.5	6.1	72.9	5.9	
QMPL10J115S	1 15/16 in.		2.25	4.81	2.81	5.93	6.36	8.38	2.44	1.25	5/8	1.00	3.11	1.87	0.24	2.87	13	
QMPL10J200S	2 in.																	
QMPL10J050S	50 mm	22211	63.5	133.4	75.9	165.1	179.3	225.6	65.5	31.8	16	28.4	83.3	50.8	4.3	79.2	7.7	
QMPL11J203S	2 3/16 in.		2.50	5.25	2.99	6.50	7.06	8.88	2.58	1.25	5/8	1.12	3.28	2.00	0.17	3.12	17	
QMPL11J204S	2 1/4 in.																	
QMPL11J055S	55 mm	22213	69.9	147.3	91.9	173.0	189.0	235.0	73.7	35.1	16	31.5	90.9	54.1	5.3	85.6	10.0	
QMPL13J060S	60 mm		2.75	5.80	3.62	6.81	7.44	9.25	2.90	1.38	5/8	1.24	3.58	2.13	0.21	3.37	22	
QMPL13J207S	2 7/16 in.																	
QMPL13J208S	2 1/2 in.																	
QMPL13J065S	65 mm	22215	82.6	167.4	101.9	195.6	213.4	265.2	76.2	35.1	20	31.8	98.3	60.2	6.4	91.9	12.7	
QMPL15J211S	2 11/16 in.		3.25	6.59	4.01	7.70	8.40	10.44	3.00	1.38	3/4	1.25	3.87	2.37	0.25	3.62	28	
QMPL15J212S	2 3/4 in.																	
QMPL15J070S	70 mm	22218	95.3	195.3	120.9	235.0	273.1	330.2	86.6	47.8	24	36.6	109.2	65.8	7.1	102.4	20.4	
QMPL15J300S	3 in.		3.75	7.69	4.76	9.25	10.75	13.00	3.41	1.88	7/8	1.44	4.30	2.59	0.28	4.03	45	
QMPL15J075S	75 mm																	
QMPL18J303S	3 3/16 in.	22220	108.0	212.9	152.4	255.0	320.0	362.0	94.7	53.8	24	41.4	122.9	75.2	6.1	116.6	26.8	
QMPL18J304S	3 1/4 in.		4.25	8.38	6.00	10.04	12.60	14.25	3.73	2.12	1	1.63	4.84	2.96	0.24	4.59	59	
QMPL18J080S	80 mm																	
QMPL18J085S	85 mm																	
QMPL18J307S	3 7/16 in.																	
QMPL18J308S	3 1/2 in.																	
QMPL18J090S	90 mm																	
QMPL20J311S	3 11/16 in.																	
QMPL20J312S	3 3/4 in.																	
QMPL20J315S	3 15/16 in.																	
QMPL20J400S	4 in.																	
QMPL20J100S	100 mm																	

QMPF FOUR-BOLT PILLOW BLOCKS

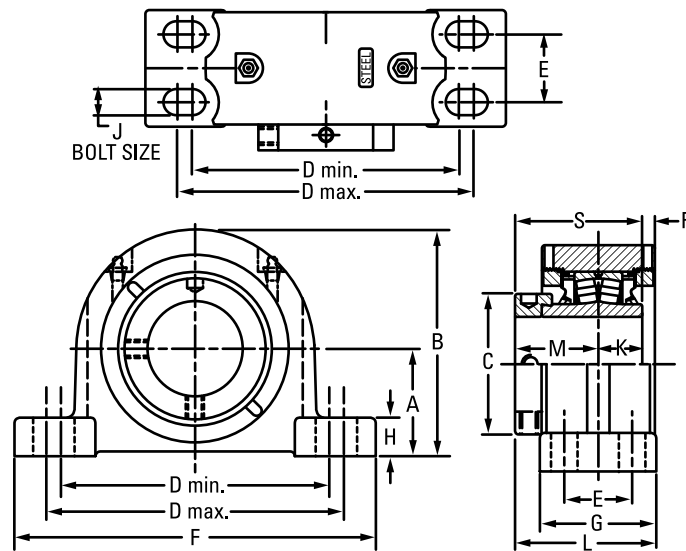

Bearing Part No.	Shaft Dia.	Bearing No.	A	B	C	D min.	D max.	E	F	G	H	J	K	L	M	R	S	Wt.
			mm in.	mm in.	mm in.	mm in.	mm in.	mm in.	mm in.	mm in.	mm in.	mm in.	mm in.	mm in.	mm in.	mm in.	mm in.	mm in.
QMPF13J060S	60 mm	22213	69.9 2.75	147.3 5.80	91.9 3.62	174.8 6.88	193.8 7.63	44.5 1.75	235.0 9.25	76.2 3.00	24.9 0.98	16 5/8	31.5 1.24	92.2 3.63	54.1 2.13	5.3 0.21	85.6 3.37	9.1 20
QMPF13J207S	2 7/16 in.																	
QMPF13J208S	2 1/2 in.																	
QMPF13J065S	65 mm	22215	82.6 3.25	167.6 6.60	101.9 4.01	193.0 7.60	231.1 9.10	47.8 1.88	265.2 10.44	79.5 3.13	32.8 1.29	16 5/8	31.8 1.25	99.8 3.93	60.2 2.37	6.1 0.24	91.9 3.62	12.2 27
QMPF15J211S	2 11/16 in.																	
QMPF15J212S	2 3/4 in.																	
QMPF15J070S	70 mm	22218	95.3 3.75	195.3 7.69	120.9 4.76	225.6 8.88	276.4 10.88	50.8 2.00	312.4 12.30	95.3 3.75	39.6 1.56	20 3/4	36.6 1.44	113.3 4.46	65.8 2.59	8.1 0.32	102.4 4.03	22.2 49
QMPF15J215S	2 15/16 in.																	
QMPF15J300S	3 in.																	
QMPF15J075S	75 mm	22220	108.0 4.25	223.0 8.78	152.4 6.00	276.4 10.88	339.9 13.38	57.2 2.25	378.0 14.88	109.5 4.31	35.6 1.40	20 3/4	41.4 1.63	130.3 5.13	75.2 2.96	9.1 0.36	116.6 4.59	30.4 67
QMPF18J303S	3 3/16 in.																	
QMPF18J304S	3 1/4 in.																	
QMPF18J080S	80 mm	22222	120.7 4.75	233.4 9.19	160.0 6.30	301.8 11.88	368.3 14.50	63.5 2.50	409.7 16.13	120.7 4.75	40.1 1.58	20 3/4	46.5 1.83	154.4 6.08	94.0 3.70	4.3 0.17	140.5 5.53	37.2 82
QMPF18J085S	85 mm																	
QMPF18J307S	3 7/16 in.																	
QMPF18J308S	90 mm	22226	139.7 5.50	279.7 11.01	175.0 6.89	349.3 13.75	403.4 15.88	69.9 2.75	444.5 17.5	128.0 5.04	39.1 1.54	24 7/8	58.7 2.31	158.8 6.25	94.7 3.73	-0.8 -0.03	153.4 6.04	60.8 134
QMPF18J090S	3 11/16 in.																	
QMPF20J311S	3 3/4 in.																	
QMPF20J312S	100 mm	23230	169.9 6.69	330.2 13.00	205.0 8.07	441.5 17.38	485.9 19.13	95.3 3.75	558.8 22.00	171.5 6.75	76.2 3.00	24 1	75.9 2.99	201.7 7.94	116.1 4.57	6.6 0.26	192.0 7.56	113.4 250
QMPF20J400S	4 in.																	
QMPF20J100S	110 mm																	
QMPF22J110S	115 mm	23234	190.5 7.50	390.7 15.38	235.0 9.25	530.4 20.88	600.2 23.63	117.5 4.625	660.4 26.00	190.5 7.50	63.5 2.50	24 1	85.1 3.35	224.3 8.83	129.0 5.08	5.6 0.22	214.1 8.43	170.1 375
QMPF22J407S	4 7/16 in.																	
QMPF22J408S	4 1/2 in.																	
QMPF26J125S	125 mm	23234	190.5 7.50	390.7 15.38	235.0 9.25	530.4 20.88	600.2 23.63	117.5 4.625	660.4 26.00	190.5 7.50	63.5 2.50	24 1	85.1 3.35	224.3 8.83	129.0 5.08	5.6 0.22	214.1 8.43	170.1 375
QMPF26J415S	4 15/16 in.																	
QMPF26J500S	5 in.																	
QMPF26J130S	130 mm	23234	190.5 7.50	390.7 15.38	235.0 9.25	530.4 20.88	600.2 23.63	117.5 4.625	660.4 26.00	190.5 7.50	63.5 2.50	24 1	85.1 3.35	224.3 8.83	129.0 5.08	5.6 0.22	214.1 8.43	170.1 375
QMPF30J507S	5 7/16 in.																	
QMPF30J508S	5 1/2 in.																	
QMPF30J140S	140 mm	23234	190.5 7.50	390.7 15.38	235.0 9.25	530.4 20.88	600.2 23.63	117.5 4.625	660.4 26.00	190.5 7.50	63.5 2.50	24 1	85.1 3.35	224.3 8.83	129.0 5.08	5.6 0.22	214.1 8.43	170.1 375
QMPF30J515S	5 15/16 in.																	
QMPF30J600S	6 in.																	
QMPF30J150S	150 mm	23234	190.5 7.50	390.7 15.38	235.0 9.25	530.4 20.88	600.2 23.63	117.5 4.625	660.4 26.00	190.5 7.50	63.5 2.50	24 1	85.1 3.35	224.3 8.83	129.0 5.08	5.6 0.22	214.1 8.43	170.1 375
QMPF34J607S	6 7/16 in.																	
QMPF34J608S	6 1/2 in.																	
QMPF34J170S	170 mm	23234	190.5 7.50	390.7 15.38	235.0 9.25	530.4 20.88	600.2 23.63	117.5 4.625	660.4 26.00	190.5 7.50	63.5 2.50	24 1	85.1 3.35	224.3 8.83	129.0 5.08	5.6 0.22	214.1 8.43	170.1 375
QMPF34J615S	6 15/16 in.																	
QMPF34J700S	7 in.																	
QMPF34J180S	180 mm																	

QMPR FOUR-BOLT PILLOW BLOCKS

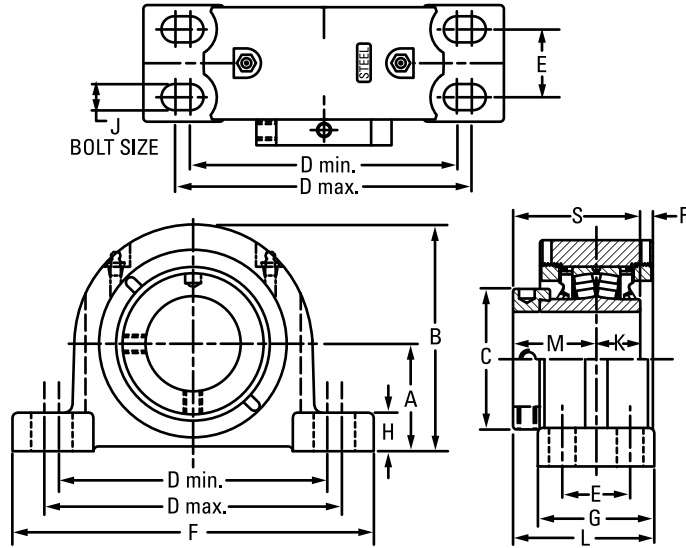

Bearing Part No.	Shaft Dia.	Bearing No.	A	B	C	D min.	D max.	E	F	G	H	J	K	L	M	R	S	Wt.	
	mm in.		mm in.	mm in.	mm in.	mm in.	mm in.	mm in.	mm in.	mm in.	mm in.	mm in.	mm in.	mm in.	mm in.	mm in.	mm in.	kg lbs.	
QMPR13J060S	60 mm	22213	69.9 2.75	147.3 5.80	91.9 3.62	181.1 7.13	222.3 8.75	47.8 1.88	260.4 10.25	82.6 3.25	24.9 0.98	16 5/8	31.5 1.24	95.5 3.76	54.1 2.13	5.3 0.21	85.6 3.37	9.1 20	
QMPR13J207S	2 7/16 in.																		
QMPR13J208S	2 1/2 in.																		
QMPR13J065S	65 mm																		
QMPR15J211S	2 11/16 in.	22215	79.5 3.13	164.3 6.47	101.9 4.01	203.2 8.00	243.8 9.60	54.1 2.13	275.1 10.83	85.9 3.38	29.5 1.16	16 5/8	31.8 1.25	103.1 4.06	60.2 2.37	6.1 0.24	91.9 3.62	12.2 27	
QMPR15J212S	2 3/4 in.																		
QMPR15J070S	70 mm																		
QMPR15J215S	2 15/16 in.																		
QMPR15J300S	3 in.	22218	95.3 3.75	195.3 7.69	120.9 4.76	235.0 9.25	285.8 11.25	60.5 2.38	346.2 13.63	95.3 3.75	39.6 1.56	20 3/4	36.6 1.44	113.3 4.46	65.8 2.59	8.1 0.32	102.4 4.03	22.2 49	
QMPR15J075S	75 mm																		
QMPR18J303S	3 3/16 in.																		
QMPR18J304S	3 1/4 in.																		
QMPR18J080S	80 mm																		
QMPR18J085S	85 mm																		
QMPR18J307S	3 7/16 in.																		
QMPR18J308S	3 1/2 in.																		
QMPR18J090S	90 mm																		

QMPH/QMPG FOUR-BOLT PILLOW BLOCKS

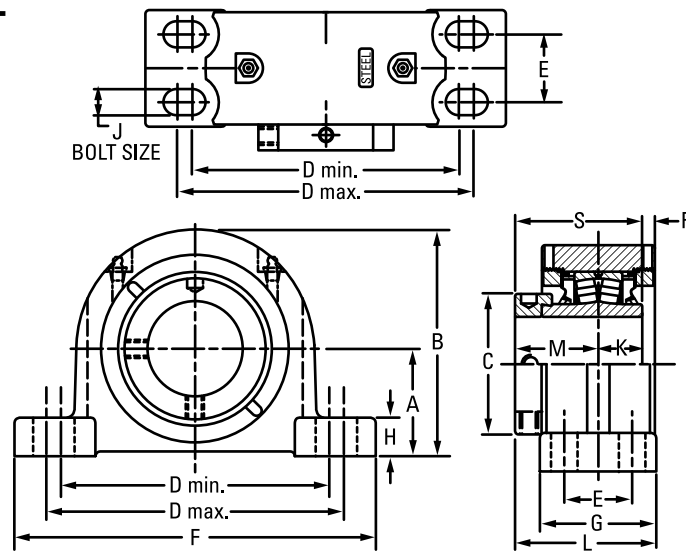

QMPH SAF STYLE FOUR-BOLT PILLOW BLOCK DIMENSIONS

Bearing Part No.	Shaft Dia.	Bearing No.	A	B	C	D min.	D max.	E	F	G	H	J	K	L	M	R	S	Wt.	
	mm in.		mm in.	mm in.	mm in.	mm in.	mm in.	mm in.	mm in.	mm in.	mm in.	mm in.	mm in.	mm in.	mm in.	mm in.	mm in.	kg lbs.	
QMPH26J125S	125 mm	22226	152.4 6.00	284 11.18	175 6.89	406.4 16.00	435.1 17.13	85.9 3.38	500.4 19.70	128 5.04	51.8 2.04	24 1	58.7 2.31	158.5 6.24	94.5 3.72	-0.7 -0.028	153.4 6.04	60.8 134	
QMPH26J415S	4 15/16 in.																		
QMPH26J500S	5 in.																		
QMPH26J130S	130 mm	23230	169.9 6.688	330.7 13.02	205.0 8.07	441.5 17.38	485.9 19.13	95.3 3.75	558.8 22.00	171.5 6.75	76.2 3.00	24 1	75.9 2.99	199.1 7.84	116.1 4.57	5.1 0.20	192.0 7.56	113.4 250	
QMPH30J507S	5 7/16 in.																		
QMPH30J508S	5 1/2 in.																		
QMPH30J140S	140 mm	23230	179.4 7.063	339.9 13.38	205.0 8.07	492.3 19.38	549.4 21.63	108.0 4.25	628.7 24.75	171.5 6.75	85.9 3.38	24 1	75.9 2.99	201.7 7.94	116.1 4.57	6.6 0.26	192.0 7.56	113.4 250	
QMPH30J515S	5 15/16 in.																		
QMPH30J600S	6 in.																		
QMPH30J150S	150 mm	23234	190.5 7.50	390.7 15.38	235.0 9.25	530.4 20.88	600.2 23.63	117.5 4.625	711.2 28.00	190.5 7.50	63.5 2.50	24 1	85.1 3.35	224.3 8.83	129.0 5.08	5.6 0.22	214.1 8.43	170.1 375	
QMPH34J607S	6 7/16 in.																		
QMPH34J608S	6 1/2 in.																		
QMPH34J170S	170 mm	23234	200.0 7.875	400.1 15.75	235.0 9.25	549.4 21.63	619.3 24.38	114.3 4.50	711.2 28.00	190.5 7.50	73.2 2.88	30 1 1/4	85.1 3.35	224.3 8.83	129.0 5.08	5.6 0.22	214.1 8.43	170.1 375	
QMPH34J616S	6 15/16 in.																		
QMPH34J700S	7 in.																		
QMPH34J180S	180 mm																		

QMPG SN STYLE FOUR-BOLT PILLOW BLOCK DIMENSIONS

Bearing Part No.	Shaft Dia.	Bearing No.	A	B	C	D min.	D max.	E	F	G	H	J	K	L	M	R	S	Wt.	
	mm in.		mm in.	mm in.	mm in.	mm in.	mm in.	mm in.	mm in.	mm in.	mm in.	mm in.	mm in.	mm in.	mm in.	mm in.	mm in.	kg lbs.	
QMPG26J125S	125 mm	22226	150.0 5.906	281.4 11.08	175.0 6.89	384.3 15.13	447.8 17.63	80.0 3.15	500.1 19.69	128 5.04	49.3 1.94	24 1	58.7 2.31	158.5 6.24	94.5 3.72	-6.9 -0.27	153.4 6.04	60.8 134	
QMPG26J415S	4 15/16 in.																		
QMPG26J500S	5 in.																		
QMPG26J130S	130 mm	23230	170.0 6.693	332.2 13.08	205.0 8.07	438.2 17.25	482.6 19.00	89.9 3.54	547.6 21.65	171.5 6.75	76.2 3.00	24 1	75.9 2.99	198.6 7.82	116.1 4.57	9.7 0.38	192.0 7.56	113.4 250	
QMPG30J507S	5 7/16 in.																		
QMPG30J508S	5 1/2 in.																		
QMPG30J140S	140 mm	23234	190.5 7.50	390.7 15.38	235.0 9.25	530.4 20.88	600.2 23.63	117.5 4.625	711.2 28.00	190.5 7.50	63.5 2.50	24 1	85.1 3.35	224.3 8.83	129.0 5.08	5.6 0.22	214.1 8.43	170.1 375	
QMPG30J515S	5 15/16 in.																		
QMPG30J600S	6 in.																		
QMPG30J150S	150 mm	23234	200.0 7.875	400.1 15.75	235.0 9.25	549.4 21.63	619.3 24.38	114.3 4.50	711.2 28.00	190.5 7.50	73.2 2.88	30 1 1/4	85.1 3.35	224.3 8.83	129.0 5.08	5.6 0.22	214.1 8.43	170.1 375	
QMPG34J607S	6 7/16 in.																		
QMPG34J608S	6 1/2 in.																		
QMPG34J170S	170 mm																		

**QMPX 5000 SERIES
FOUR-BOLT
PILLOW BLOCKS**

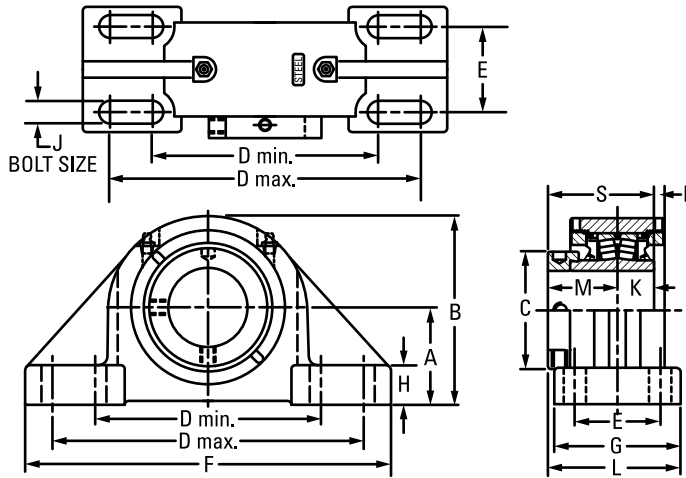

Bearing Part No.	Shaft Dia.	Bearing No.	A	B	C	D min.	D max.	E	F	G	H	J	K	L	M	R	S	Wt.
	mm in.		mm in.	mm in.	mm in.	mm in.	mm in.	mm in.	mm in.	mm in.	mm in.	mm in.	mm in.	mm in.	mm in.	mm in.	mm in.	kg lbs.
QMPX13J060S	60 mm	22213	76.2 3.00	153.7 6.05	91.9 3.62	176.3 6.94	242.8 9.56	66.8 2.63	285.8 11.25	98.6 3.88	31.0 1.22	16 5/8	31.5 1.24	103.4 4.07	54.1 2.13	5.3 0.21	85.6 3.37	10.4 23
QMPX13J207S	2 7/16 in.																	
QMPX13J208S	2 1/2 in.																	
QMPX13J065S	65 mm	22215	88.9 3.50	173.5 6.83	101.9 4.01	230.1 9.06	265.2 10.44	68.9 2.75	330.2 13.00	108.0 4.25	39.1 1.54	20 3/4	31.8 1.25	114.3 4.50	60.2 2.37	7.1 0.28	91.9 3.62	12.7 28
QMPX15J211S	2 11/16 in.																	
QMPX15J212S	2 3/4 in.																	
QMPX15J070S	70 mm	22218	101.6 4.00	201.2 7.92	120.9 4.76	274.6 10.81	309.6 12.19	76.2 3.00	381.0 15.00	120.7 4.75	38.1 1.50	20 3/4	36.6 1.44	126.0 4.96	65.8 2.59	8.1 0.32	102.4 4.03	22.2 49
QMPX18J303S	3 3/16 in.																	
QMPX18J304S	3 1/4 in.																	
QMPX18J080S	80 mm	22220	127.0 5.00	239.8 9.44	152.4 6.00	317.5 12.50	355.6 14.00	88.9 3.50	425.5 16.75	139.7 5.50	41.4 1.63	24 7/8	41.4 1.63	145.3 5.72	75.2 2.96	8.6 0.34	116.6 4.59	30.4 67
QMPX18J085S	85 mm																	
QMPX18J307S	3 7/16 in.																	
QMPX18J308S	3 1/2 in.	22222	146.1 5.75	273.8 10.78	160.0 6.30	354.1 13.94	395.2 15.56	101.6 4.00	469.9 18.50	158.8 6.25	45.7 1.80	24 1	46.5 1.83	171.2 6.74	94.0 3.70	2.3 0.09	140.5 5.53	37.2 82
QMPX18J090S	90 mm																	
QMPX20J311S	3 11/16 in.																	
QMPX20J312S	3 3/4 in.	22226	155.6 6.125	283.2 11.15	175.0 6.89	387.4 15.25	425.5 16.75	108.0 4.25	514.4 20.25	171.5 6.75	50.8 2.00	24 1 1/8	58.7 2.31	180.3 7.10	94.5 3.72	-1.5 -0.06	153.4 6.04	60.8 134
QMPX20J400S	4 in.																	
QMPX20J100S	100 mm																	
QMPX22J110S	110 mm	23230	169.9 6.688	330.2 13.00	205.0 8.07	439.9 17.32	485.8 19.125	93.5 3.68	558.8 22.00	171.5 6.75	76.2 3.00	24 1 1/8	75.9 2.99	201.7 7.94	116.1 4.57	6.6 0.26	192.0 7.56	113.4 250
QMPX22J407S	4 7/16 in.																	
QMPX22J408S	4 1/2 in.																	
QMPX22J115S	115 mm	23230	179.4 7.063	339.9 13.38	205.0 8.07	489.0 19.25	552.5 21.75	106.4 4.188	625.7 24.75	171.5 6.75	85.6 3.37	24 1 1/8	75.9 2.99	196.9 7.75	116.1 4.57	4.8 0.19	192.0 7.56	113.4 250
QMPX26J125S	125 mm																	
QMPX26J415S	4 15/16 in.																	
QMPX26J500S	5 in.	23234	200.0 7.875	400.1 15.75	235.0 9.25	549.4 21.63	619.3 24.38	112.8 4.44	711.2 28.00	190.5 7.50	73.2 2.88	30 1 1/4	80.1 3.35	224.3 8.83	129.0 5.08	5.6 0.22	214.1 8.43	179.2 395
QMPX26J130S	130 mm																	
QMPX30J507S	5 7/16 in.																	
QMPX30J508S	5 1/2 in.	23234	179.4 7.063	339.9 13.38	205.0 8.07	489.0 19.25	552.5 21.75	106.4 4.188	625.7 24.75	171.5 6.75	85.6 3.37	24 1 1/8	75.9 2.99	196.9 7.75	116.1 4.57	4.8 0.19	192.0 7.56	113.4 250
QMPX30J140S	140 mm																	
QMPX30J515S ⁽¹⁾	5 15/16 in.																	
QMPX30J600S ⁽¹⁾	6 in.	23234	200.0 7.875	400.1 15.75	235.0 9.25	549.4 21.63	619.3 24.38	112.8 4.44	711.2 28.00	190.5 7.50	73.2 2.88	30 1 1/4	80.1 3.35	224.3 8.83	129.0 5.08	5.6 0.22	214.1 8.43	179.2 395
QMPX30J150S ⁽¹⁾	150 mm																	
QMPX34J607S ⁽¹⁾	6 7/16 in.																	
QMPX34J608S ⁽¹⁾	6 1/2 in.	23234	200.0 7.875	400.1 15.75	235.0 9.25	549.4 21.63	619.3 24.38	112.8 4.44	711.2 28.00	190.5 7.50	73.2 2.88	30 1 1/4	80.1 3.35	224.3 8.83	129.0 5.08	5.6 0.22	214.1 8.43	179.2 395
QMPX34J170S ⁽¹⁾	170 mm																	
QMPX34J615S ⁽¹⁾	6 15/16 in.																	
QMPX34J700S ⁽¹⁾	7 in.	23234	200.0 7.875	400.1 15.75	235.0 9.25	549.4 21.63	619.3 24.38	112.8 4.44	711.2 28.00	190.5 7.50	73.2 2.88	30 1 1/4	80.1 3.35	224.3 8.83	129.0 5.08	5.6 0.22	214.1 8.43	179.2 395
QMPX34J180S ⁽¹⁾	180 mm																	

⁽¹⁾No gussets on outside housing.

QMPXT 5000 SERIES TWO-BOLT PILLOW BLOCKS

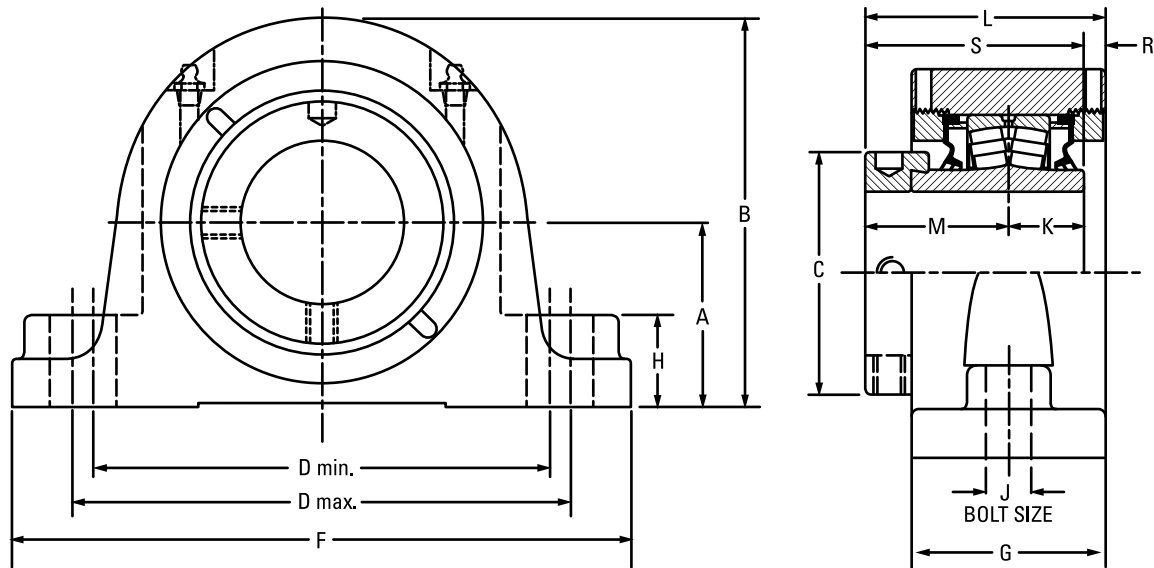

Bearing Part No.	Shaft Dia.	Bearing No.	A	B	C	D min.	D max.	F	G	H	J	K	L	M	R	S	Wt.	
	mm in.		mm in.	mm in.	mm in.	mm in.	mm in.	mm in.	mm in.	mm in.	mm in.	mm in.	mm in.	mm in.	mm in.	mm in.	kg lbs.	
QMPXT13J060S	60 mm	22213	76.2	153.7	91.9	194.6	223.0	285.8	73.7	35.1	20	31.5	91.4	54.1	5.3	85.6	10.0	
QMPXT13J207S	2 7/16 in.		3.00	6.05	3.62	7.66	8.78	11.25	2.90	1.38	3/4	1.24	3.60	2.13	0.21	3.37	22	
QMPXT13J208S	2 1/2 in.																	
QMPXT13J065S	65 mm																	
QMPXT15J211S	2 11/16 in.	22215	88.9	173.7	101.9	230.1	265.2	330.2	75.7	35.1	24	31.8	98.0	60.2	6.1	91.9	12.7	
QMPXT15J212S	2 3/4 in.		3.50	6.84	4.01	9.06	10.44	13.00	2.98	1.38	7/8	1.25	3.86	2.37	0.24	3.62	28	
QMPXT15J070S	70 mm																	
QMPXT15J215S	2 15/16 in.																	
QMPXT15J300S	3 in.																	
QMPXT15J075S	75 mm																	

QMSN SN-STYLE TWO-BOLT PILLOW BLOCKS – PURE METRIC DESIGN

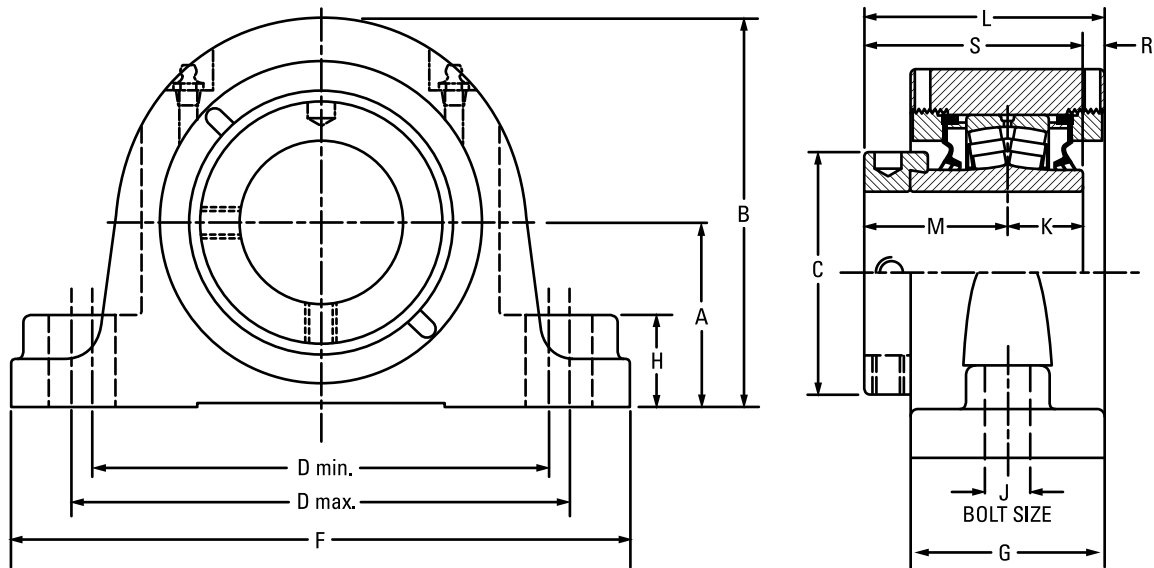

Bearing Part No.	Shaft Dia.	Bearing No.	A	B	C	D min.	D max.	F	G	H	J	K	L	M	R	S	Wt.
			mm in.	mm in.	mm in.	mm in.	mm in.	mm in.	mm in.	mm in.	mm in.	mm in.	mm in.	mm in.	mm in.	mm in.	mm in.
QMSN08J035S	35 mm	22208	60	111	60.5	159	175	205	62	35	12	25	75	44	5	70	10.5
QMSN08J107S	1 7/16 in.		2.36	4.37	2.38	6.26	6.89	8.07	2.44	1.38	1/2	1.00	2.95	1.75	0.20	2.75	23
QMSN08J108S	1 1/2 in.																
QMSN09J040S	40 mm	22209	60	111	67	159	175	205	62	35	12	25	79	48	6	73	10.5
QMSN09J111S	1 11/16 in.		2.36	4.37	2.64	6.26	6.89	8.07	2.44	1.38	1/2	0.98	3.11	1.89	0.24	2.87	23
QMSN09J112S	1 3/4 in.																
QMSN09J045S	45 mm	22210	70	136	70	183	216	254	68	25	16	25	82	48	9	73	12.7
QMSN10J115S	1 15/16 in.		2.76	5.35	2.76	7.20	8.50	10.00	2.68	0.98	5/8	0.98	3.23	1.89	0.35	2.87	28
QMSN10J200S	2 in.																
QMSN10J050S	50 mm	22211	70	141	76	183	216	254	68	25	16	29	85	51	6	80	13.2
QMSN11J203S	2 3/16 in.		2.76	5.55	2.99	7.20	8.50	10.00	2.68	0.98	5/8	1.14	3.35	2.01	0.24	3.15	29
QMSN11J204S	2 1/4 in.																
QMSN11J055S	55 mm	22213	80	157	92	196	235	275	74	35	16	31	91	55	5	86	15.9
QMSN13J060S	60 mm		3.15	6.18	3.62	7.72	9.25	10.83	2.91	1.38	5/8	1.22	3.58	2.17	0.20	3.39	35
QMSN13J207S	2 7/16 in.																
QMSN13J208S	2 1/2 in.	22215	95	183	102	241	279	316	76	34	20	32	98	60	6	92	20.9
QMSN13J065S	65 mm		3.74	7.20	4.02	9.49	10.98	12.44	2.99	1.34	3/4	1.26	3.86	2.36	0.24	3.62	46
QMSN15J211S	2 11/16 in.																
QMSN15J212S	2 3/4 in.	22218	100	200	121	279	292	345	86	39	20	37	109	66	7	103	25.5
QMSN15J070S	70 mm		3.94	7.87	4.76	10.98	11.50	13.58	3.39	1.54	3/4	1.46	4.29	2.60	0.28	4.06	56
QMSN15J215S	2 15/16 in.																
QMSN15J300S	3 in.																
QMSN15J075S	75 mm																
QMSN18J303S	3 3/16 in.																
QMSN18J304S	3 1/4 in.																
QMSN18J080S	80 mm																

Continued on next page.

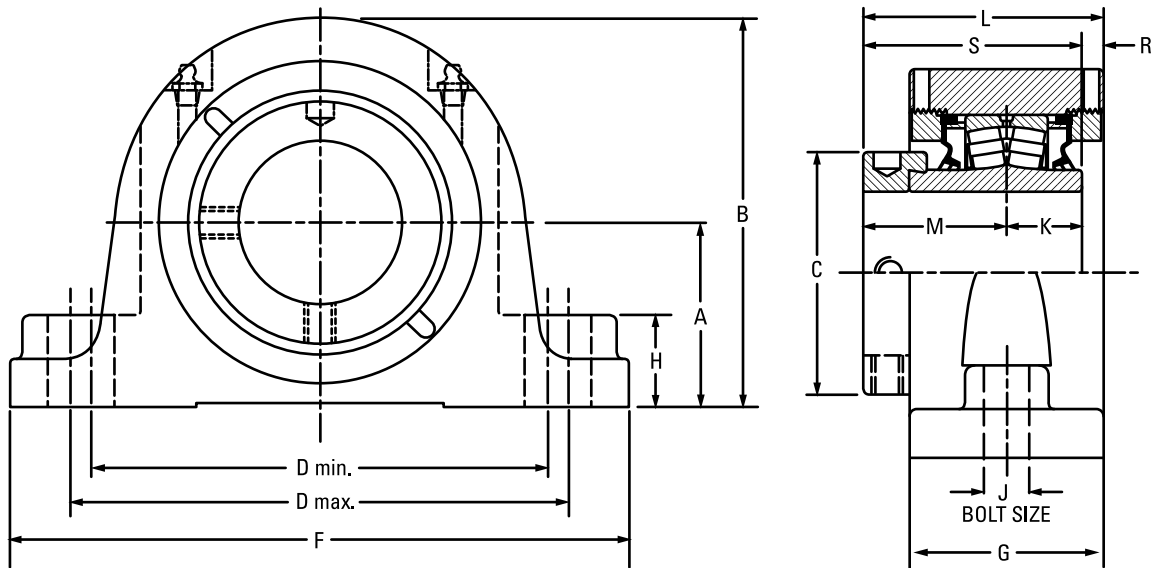

Continued from previous page.

Bearing Part No.	Shaft Dia.	Bearing No.	A	B	C	D min.	D max.	F	G	H	J	K	L	M	R	S	Wt.
			mm in.	mm in.	mm in.	mm in.	mm in.	mm in.	mm in.	mm in.	mm in.	mm in.	mm in.	mm in.	mm in.	mm in.	mm in.
QMSN18J085S	85 mm	22218	112 4.41	212 8.35	121 4.76	279 10.98	292 11.50	345 13.58	86 3.39	39 1.54	20 3/4	37 1.46	109 4.29	66 2.60	7 0.28	103 4.06	25.5 56
QMSN18J307S	3 7/16 in.	22218	112 4.41	212 8.35	121 4.76	290 11.42	327 12.87	380 14.96	86 3.39	39 1.54	24 7/8	37 1.46	109 4.29	66 2.60	7 0.28	103 4.06	25.5 56
QMSN18J308S	3 1/2 in.																
QMSN18J090S	90 mm																
QMSN20J311S	3 11/16 in.	22220	125 4.92	241 9.49	152 5.98	319 12.56	366 14.41	410 16.14	101 3.98	50 1.97	24 7/8	41 1.61	126 4.96	75 2.95	9 0.35	116 4.57	35.9 79
QMSN20J312S	3 3/4 in.																
QMSN20J315S	3 15/16 in.																
QMSN20J400S	4 in.																
QMSN20J100S	100 mm	22222	140 5.51	255 10.04	160 6.30	332 13.07	365 14.37	410 16.14	105 4.13	39 1.54	24 7/8	47 1.85	147 5.79	94 3.70	6 0.24	141 5.55	35.9 79
QMSN22J110S	110 mm																
QMSN22J407S	4 7/16 in.																
QMSN22J408S	4 1/2 in.	22222	150 5.91	265 10.43	160 6.30	367 14.45	400 15.75	445 17.52	105 4.13	49 1.93	24 7/8	47 1.85	147 5.79	94 3.70	6 0.24	141 5.55	35.5 78
QMSN22J115S	115 mm																
QMSN26J125S	125 mm																
QMSN26J415S	4 15/16 in.	22226	150 5.91	282 11.10	175 6.89	402 15.83	435 17.13	500 19.69	113 4.45	49 1.93	30 1 1/4	58 2.28	151 5.94	95 3.74	2 0.08	153 6.02	40.0 88
QMSN26J500S	5 in.																
QMSN26J130S	130 mm																
QMSN30J507S	5 7/16 in.	23230	170 6.69	330 13.01	205 8.07	461 18.15	479 18.86	550 21.65	171 6.75	76 3.01	30 1 1/4	76 2.99	202 7.94	116 4.57	7 0.26	192 7.56	136.4 300
QMSN30J508S	5 1/2 in.																
QMSN30J140S	140mm																
QMSN30J515S	5 15/16 in.																
QMSN30J600S	6 in.																
QMSN30J150S	150mm																

QMC PILOTED FLANGE CARTRIDGES

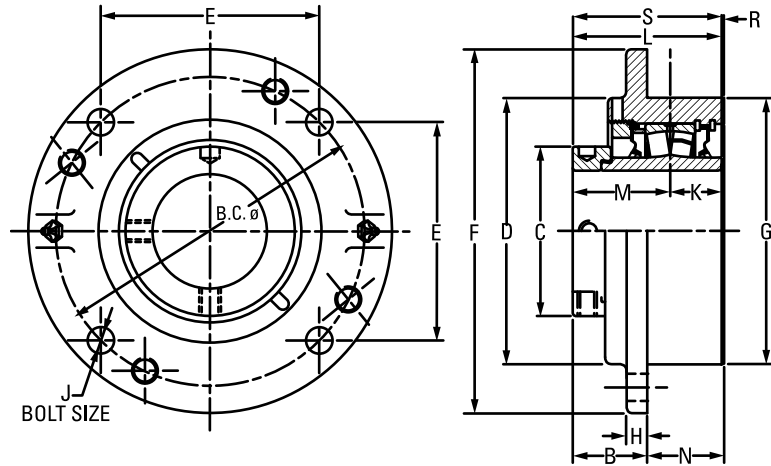

Bearing Part No.	Shaft Dia.	Bearing No.	B _{FIX}	B _{EXP}	B.C.	C	D	E	F	G ⁽¹⁾	H	J	K	L _{FIX}	L _{EXP}	M	N	R	S	Wt.	
	mm in.		mm in.	mm in.	mm in.	mm in.	mm in.	mm in.	mm in.	mm in.	mm in.	mm in.	mm in.	mm in.	mm in.	mm in.	mm in.	mm in.	mm in.	mm in.	kg lbs.
QMC08J035S	35 mm	22208	49.8	51.8	111.3	60.5	92.2	78.5	133.4	92.1	12.7	10	25.4	73.7	75.7	44.5	23.9	3.81	69.9	3.6	
QMC08J107S	1 7/16 in.		1.96	2.04	4.38	2.38	3.63	3.09	5.25	3.625	0.50	7/16	1.00	2.90	2.98	1.75	0.94	0.15	2.75	8	
QMC08J108S	1 1/2 in.																				
QMC09J040S	40 mm	22209	54.6	56.6	130.3	66.8	111.3	91.9	155.7	108.0	12.7	10	25.4	77.0	79.0	47.5	22.4	3.81	72.9	4.1	
QMC09J111S	1 11/16 in.		2.15	2.23	5.13	2.63	4.38	3.62	6.13	4.250	0.50	7/16	1.00	3.03	3.11	1.87	0.88	0.15	2.87	9	
QMC09J112S	1 3/4 in.																				
QMC09J045S	45 mm	22210	50.4	52.6	136.7	70.1	113.5	96.5	162.1	114.3	16.0	10	25.4	77.5	79.5	47.5	26.9	4.6	72.9	4.5	
QMC10J115S	1 15/16 in.		1.99	2.07	5.38	2.76	4.47	3.80	6.38	4.500	0.63	7/16	1.00	3.05	3.13	1.87	1.06	0.18	2.87	10	
QMC10J200S	2 in.																				
QMC10J050S	50 mm	22211	54.4	56.4	152.4	75.9	127.0	107.7	185.4	127.0	14.7	12	28.7	83.1	85.1	50.5	28.7	3.6	79.2	5.9	
QMC11J203S	2 3/16 in.		2.14	2.22	6.00	2.99	5.00	4.24	7.30	5.000	0.58	1/2	1.13	3.27	3.35	1.99	1.13	0.14	3.12	13	
QMC11J204S	2 1/4 in.																				
QMC11J055S	55 mm	22213	59.4	61.5	165.1	91.9	139.7	116.8	193.8	139.7	17.5	12	31.5	87.9	91.2	54.1	28.7	2.3	85.6	7.3	
QMC13J060S	60 mm		2.34	2.42	6.50	3.62	5.50	4.60	7.63	5.500	0.69	1/2	1.24	3.46	3.59	2.13	1.13	0.09	3.37	16	
QMC13J207S	2 7/16 in.																				
QMC13J208S	2 1/2 in.																				
QMC13J065S	65 mm	22215	62.5	64.5	190.5	101.9	162.1	134.6	222.3	161.9	20.6	16	31.8	94.5	96.5	60.2	31.8	2.3	91.9	10.0	
QMC15J211S	2 11/16 in.		2.46	2.54	7.50	4.01	6.38	5.30	8.75	6.375	0.81	5/8	1.25	3.72	3.80	2.37	1.25	0.09	3.62	22	
QMC15J212S	2 3/4 in.																				
QMC15J070S	70 mm	22218	73.2	75.2	219.2	120.9	187.5	154.9	262.6	187.3	25.4	20	36.6	106.4	108.5	65.8	33.3	4.1	102.4	14.5	
QMC15J215S	2 15/16 in.		2.88	2.96	8.63	4.76	7.38	6.10	10.34	7.375	1.00	3/4	1.44	4.19	4.27	2.59	1.31	0.16	4.03	32	
QMC15J300S	3 in.																				
QMC15J075S	75 mm	22220	72.1	74.2	238.3	152.4	206.5	168.4	276.4	206.4	25.4	20	41.4	126.0	128.0	75.2	54.1	9.4	115.8	19.5	
QMC18J303S	3 3/16 in.		2.84	2.92	9.38	6.00	8.13	6.63	10.88	8.125	1.00	3/4	1.63	4.96	5.04	2.96	2.13	0.37	4.56	43	
QMC18J304S	3 1/4 in.																				
QMC18J080S	80 mm	22222	92.5	94.5	298.5	160.0	254.0	149.4	342.9	260.4	25.4	20	46.5	140.7	142.7	94.0	48.3	0.3	140.5	32.7	
QMC18J085S	85 mm		3.64	3.72	11.75 ⁽²⁾	6.30	10.00	5.88 ⁽²⁾	13.50	10.250	1.00	3/4 ⁽²⁾	1.83	5.54	5.62	3.70	1.90	0.01	5.53	72	
QMC18J307S	3 7/16 in.																				
QMC18J308S	3 1/2 in.																				
QMC18J090S	90 mm																				
QMC20J311S	3 11/16 in.																				
QMC20J312S	3 3/4 in.																				
QMC20J315S	3 15/16 in.																				
QMC20J400S	4 in.																				
QMC20J100S	100 mm																				
QMC22J110S ⁽²⁾	110 mm																				
QMC22J407S ⁽²⁾	4 7/16 in.																				
QMC22J408S ⁽²⁾	4 1/2 in.																				
QMC22J115S ⁽²⁾	115 mm																				

⁽¹⁾Pilot tolerance: +0/-0.051 mm (+0/-0.002 in.).

⁽²⁾Six-bolt housing.

QMCW PILOTED FLANGE CARTRIDGES

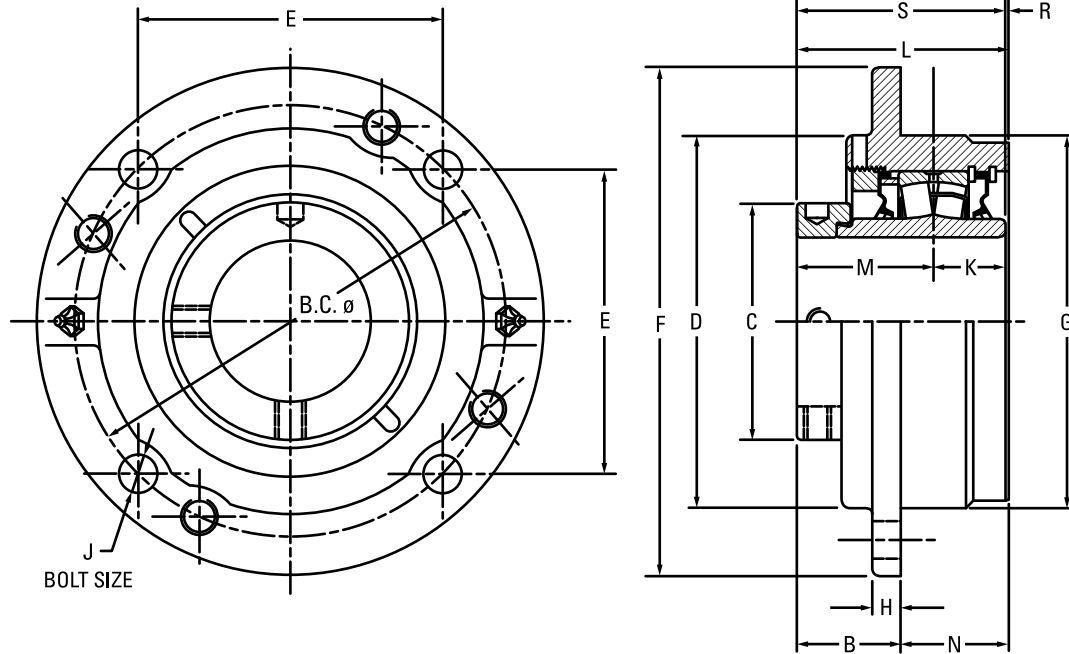

Bearing Part No.	Shaft Dia.	Bearing No.	B _{FIX}	B _{EXP}	B.C.	C	D	E	F	G ⁽¹⁾	H	J	K	L _{FIX}	L _{EXP}	M	N	R	S	Wt.	
			mm in.	mm in.	mm in.	mm in.	mm in.	mm in.	mm in.	mm in.	mm in.	mm in.	mm in.	mm in.	mm in.	mm in.	mm in.	mm in.	mm in.	mm in.	mm in.
QMCW08J035S	35 mm	22208	38.6	40.9	111.3	59.9	92.2	78.5	133.4	92.1	12.7	10	25.4	73.7	75.7	44.5	35.1	3.8	69.9	3.6	
QMCW08J107S	1 7/16 in.		1.53	1.61	4.38	2.36	3.63	3.09	5.25	3.625	0.50	7/16	1.00	2.90	2.98	1.75	1.38	0.15	2.75	8	
QMCW08J108S	1 1/2 in.																				
QMCW09J040S	40 mm	22209	38.9	40.1	130.3	66.8	111.3	91.9	155.7	108.0	10.2	10	25.1	77.0	78.2	47.8	38.1	4.1	72.9	4.1	
QMCW09J111S	1 11/16 in.		1.53	1.58	5.13	2.63	4.38	3.62	6.13	4.250	0.40	7/16	0.99	3.03	3.08	1.88	1.50	0.16	2.87	9	
QMCW09J112S	1 3/4 in.																				
QMCW09J045S	45 mm	22210	39.1	41.1	136.7	70.1	113.5	96.5	162.1	114.3	9.7	10	24.9	77.2	79.2	48.0	38.1	4.3	72.9	4.5	
QMCW10J115S	1 15/16 in.		1.54	1.62	5.38	2.76	4.47	3.80	6.38	4.500	0.38	7/16	0.98	3.04	3.12	1.89	1.50	0.17	2.87	10	
QMCW10J200S	2 in.																				
QMCW10J050S	50 mm	22211	45.7	47.8	152.4	75.9	127.0	107.7	181.1	127.0	14.2	12	28.7	86.9	88.9	50.5	41.4	7.62	79.2	5.9	
QMCW11J203S	2 3/16 in.		1.80	1.88	6.00	2.99	5.00	4.24	7.13	5.000	0.56	1/2	1.13	3.42	3.50	1.99	1.63	0.30	3.12	13	
QMCW11J204S	2 1/4 in.																				
QMCW11J055S	55 mm	22213	47.5	49.5	165.1	91.9	139.7	116.8	193.8	139.7	12.7	12	31.5	90.2	92.2	54.1	42.9	4.31	85.6	7.3	
QMCW13J060S	60 mm		1.87	1.95	6.50	3.62	5.50	4.60	7.63	5.500	0.50	1/2	1.24	3.55	3.63	2.13	1.69	0.17	3.37	16	
QMCW13J207S	2 7/16 in.																				
QMCW13J208S	2 1/2 in.																				
QMCW13J065S	65 mm	22215	46.0	48.0	190.5	101.9	162.1	134.6	222.3	161.9	12.7	16	31.8	93.5	95.5	60.2	47.8	1.5	91.9	10.0	
QMCW15J211S	2 11/16 in.		1.81	1.89	7.50	4.01	6.38	5.30	8.75	6.375	0.50	5/8	1.25	3.68	3.76	2.37	1.88	0.06	3.62	22	
QMCW15J212S	2 3/4 in.																				
QMCW15J070S	70 mm	22218	62.5	64.5	219.2	120.9	187.5	154.9	260.4	187.3	22.4	20	36.6	110.2	112.3	65.8	47.8	7.9	102.4	14.5	
QMCW15J300S	3 in.		2.46	2.54	8.63	4.76	7.38	6.10	10.25	7.375	0.88	3/4	1.44	4.34	4.42	2.59	1.88	0.31	4.03	32	
QMCW15J075S	75 mm																				
QMCW18J303S	3 3/16 in.																				
QMCW18J304S	3 1/4 in.																				
QMCW18J080S	80 mm																				
QMCW18J085S	85 mm																				
QMCW18J307S	3 7/16 in.																				
QMCW18J308S	3 1/2 in.																				
QMCW18J090S	90 mm																				

⁽¹⁾Pilot tolerance: +0/-0.05 mm (+0/-0.002 in.).

⁽²⁾Six-bolt housing.

Continued on next page.

QMCW PILOTED FLANGE CARTRIDGES – continued

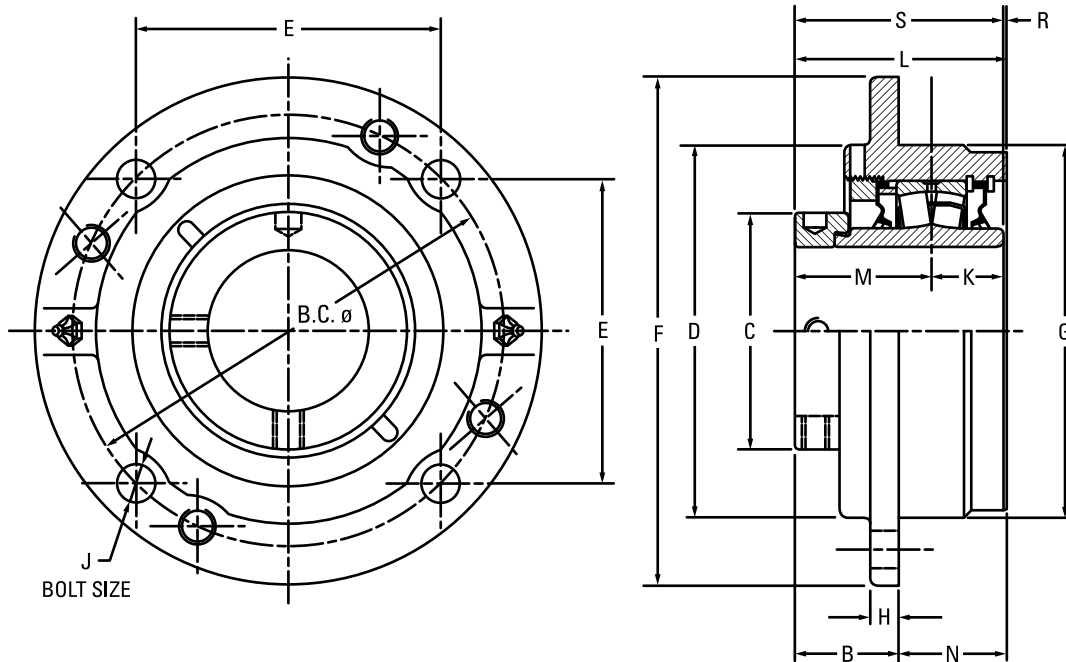

Continued from previous page.

Bearing Part No.	Shaft Dia.	Bearing No.	B _{FIX}	B _{EXP}	B.C.	C	D	E	F	G ⁽¹⁾	H	J	K	L _{FIX}	L _{EXP}	M	N	R	S	Wt.	
	mm in.		mm in.	mm in.	mm in.	mm in.	mm in.	mm in.	mm in.	mm in.	mm in.	mm in.	mm in.	mm in.	mm in.	mm in.	mm in.	mm in.	mm in.	mm in.	kg lbs.
QMCW20J311S	3 11/16 in.	22220	63.5 2.50	65.5 2.58	238.3 9.38	152.4 6.00	206.5 8.13	168.4 6.63	276.4 10.88	206.4 8.125	25.4 1.00	20 3/4	41.4 1.63	120.7 4.75	122.7 4.83	75.2 2.96	57.2 2.25	4.1 0.16	116.6 4.59	19.5 43	
QMCW20J312S	3 3/4 in.																				
QMCW20J315S	3 15/16 in.																				
QMCW20J400S	4 in.																				
QMCW20J100S	100 mm	22222	76.5 3.01	78.5 3.09	298.5 11.75 ⁽²⁾	160.0 6.30	254.0 10.00	149.4 5.88 ⁽²⁾	342.9 13.50	260.4 10.250	25.4 1.00	20 3/4 ⁽²⁾	46.5 1.83	144.8 5.70	146.8 5.78	94.0 3.70	68.3 2.69	4.3 0.17	140.5 5.53	32.7 72	
QMCW22J110S ⁽²⁾	110 mm																				
QMCW22J407S ⁽²⁾	4 7/16 in.																				
QMCW22J408S ⁽²⁾	4 1/2 in.																				
QMCW22J115S ⁽²⁾	115 mm	22226	73.7 2.90	75.7 2.98	323.9 12.75 ⁽²⁾	175.0 6.89	266.7 10.50	162.1 6.38 ⁽²⁾	374.7 14.75	279.4 11.000	26.2 1.03	24 7/8 ⁽²⁾	58.7 2.31	151.4 5.96	153.4 6.04	94.7 3.73	77.9 3.065	-1.8 -0.07	153.4 6.04	46.3 102	
QMCW26J125S ⁽²⁾	125 mm																				
QMCW26J415S ⁽²⁾	4 15/16 in.																				
QMCW26J500S ⁽²⁾	5 in.																				
QMCW26J130S ⁽²⁾	130 mm	23230	82.8 3.26	84.8 3.34	368.3 14.50 ⁽²⁾	205.0 8.07	304.8 12.00	184.2 7.25 ⁽²⁾	431.8 17.00	330.2 13.000	26.2 1.03	24 7/8 ⁽²⁾	75.9 2.99	204.2 8.04	206.2 8.12	116.1 4.57	121.4 4.78	12.2 0.48	192.0 7.56	102.5 226	
QMCW30J507S ⁽²⁾	5 7/16 in.																				
QMCW30J508S ⁽²⁾	5 1/2 in.																				
QMCW30J140S ⁽²⁾	140 mm																				
QMCW30J515S ⁽²⁾	5 15/16 in.	23230	82.8 3.26	84.8 3.34	419.1 16.50 ⁽²⁾	205.0 8.07	304.8 12.00	209.6 8.25 ⁽²⁾	482.6 19.00	355.6 14.000	26.2 1.03	24 7/8 ⁽²⁾	75.9 2.99	211.3 8.32	213.4 8.40	116.1 4.57	128.5 5.06	19.3 0.76	192.0 7.56	101.6 224	
QMCW30J600S ⁽²⁾	6 in.																				
QMCW30J150S ⁽²⁾	150 mm																				
QMCW34J607S ⁽²⁾	6 7/16 in.																				
QMCW34J608S ⁽²⁾	6 1/2 in.	23234	85.9 3.38	87.9 3.46	431.8 17.00	235.0 9.25	355.6 14.00	215.9 8.50	482.6 19.00	381.0 15.000	28.7 1.13	24 1 ⁽²⁾	85.1 3.35	216.2 8.51	218.2 8.59	129.0 5.08	130.3 5.13	2.0 0.08	214.1 8.43	152.4 336	
QMCW34J170S ⁽²⁾	170 mm																				
QMCW34J615S ⁽²⁾	6 15/16 in.																				
QMCW34J700S ⁽²⁾	7 in.																				
QMCW34J180S ⁽²⁾	180 mm																				

⁽¹⁾Pilot tolerance: +0/-0.05 mm (+0/-0.002 in.).

⁽²⁾Six-bolt housing.

QMF FOUR-BOLT SQUARE FLANGE BLOCKS

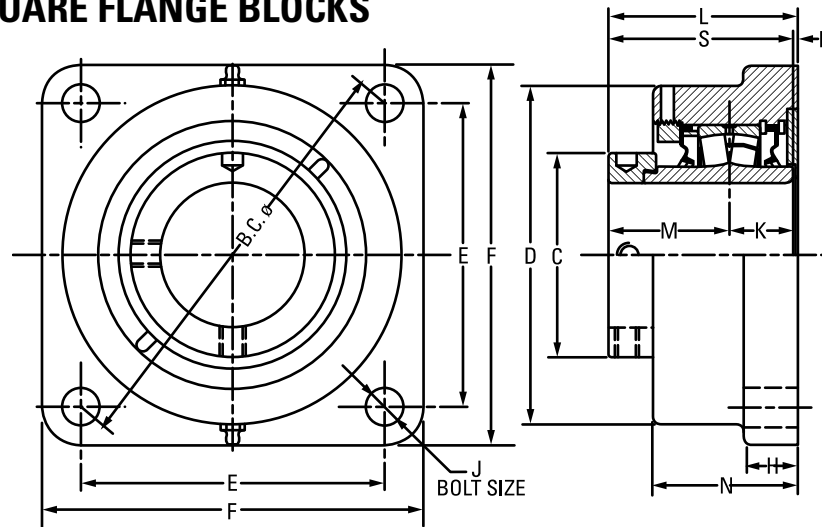

Bearing Part No.	Shaft Dia.	Bearing No.	B.C.	C	D	E	F	H	J	K	L FIX	L EXP	M	N	R	S	Wt.	
	mm in.		mm in.	mm in.	mm in.	mm in.	mm in.	mm in.	mm in.	mm in.	mm in.	mm in.	mm in.	mm in.	mm in.	mm in.	lbs. kg	
QMF08J035S	35 mm	22208	127.7	60.5	93.7	88.9	117.6	22.4	12	25.4	72.9	74.9	44.5	57.2	3.0	69.9	4.5	
QMF08J107S	1 7/16 in.		4.95	2.38	3.69	3.50	4.63	0.88	1/2	1.00	2.87	2.95	1.75	2.25	0.12	2.75	10	
QMF08J108S	1 1/2 in.	22208	148.3	60.5	108.0	104.9	136.7	22.4	12	25.4	73.7	75.7	44.5	59.4	3.8	69.9	4.5	
QMF09J111S	1 11/16 in.	22209	148.3	66.8	118.4	104.9	136.7	22.4	12	25.4	79.5	81.5	47.8	63.5	6.4	73.2	5.0	
QMF09J040S	40 mm		5.84	2.63	4.66	4.13	5.38	0.88	1/2	1.00	3.13	3.21	1.88	2.50	0.25	2.88	11	
QMF09J112S	1 3/4 in.	22209	157.2	66.8	118.4	111.3	143.0	22.4	12	25.4	79.5	81.5	47.8	63.5	6.4	72.9	5.0	
QMF09J045S	45 mm		6.19	2.63	4.66	4.38	5.63	0.88	1/2	1.00	3.13	3.21	1.88	2.50	0.25	2.87	11	
QMF10J115S	1 15/16 in.	22210	157.2	70.1	120.7	111.3	139.7	22.4	12	24.4	80.8	82.8	48.0	65.0	7.9	72.9	5.0	
QMF10J200S	2 in.		6.19	2.76	4.75	4.38	5.50	0.88	1/2	0.98	3.18	3.26	1.89	2.56	0.31	2.87	11	
QMF10J050S	50 mm																	
QMF11J203S	2 3/16 in.	22211	175.0	75.9	130.3	124.0	157.2	25.4	16	28.7	82.8	84.8	50.5	66.8	3.3	79.2	6.4	
QMF11J204S	2 1/4 in.		6.89	2.99	5.13	4.88	6.19	1.00	5/8	1.13	3.26	3.34	1.99	2.63	0.13	3.12	14	
QMF11J055S	55 mm																	
QMF13J060S	60 mm	22213	193.0	91.9	146.1	136.7	168.4	25.4	16	31.5	88.6	90.7	54.1	72.4	3.0	85.6	7.7	
QMF13J207S	2 7/16 in.		7.60	3.62	5.75	5.38	6.63	1.00	5/8	1.24	3.49	3.57	2.13	2.85	0.12	3.37	17	
QMF13J208S	2 1/2 in.																	
QMF13J065S	65 mm																	
QMF15J211S	2 11/16 in.	22215	215.6	101.9	168.9	152.4	189.0	26.9	20	31.8	96.0	98.0	60.2	76.2	4.1	91.9	10.4	
QMF15J212S	2 3/4 in.		8.49	4.01	6.65	6.00	7.44	1.06	3/4	1.25	3.78	3.86	2.37	3.00	0.16	3.62	23	
QMF15J070S	70 mm																	
QMF15J215S	2 15/16 in.	22218	251.7	120.9	193.8	177.8	219.2	33.3	20	36.6	107.2	109.2	66.8	84.1	4.8	102.4	15.9	
QMF15J300S	3 in.		9.91	4.76	7.63	7.00	8.63	1.31	3/4	1.44	4.22	4.30	2.59	3.31	0.19	4.03	35	
QMF15J075S	75 mm																	
QMF18J303S	3 3/16 in.																	
QMF18J304S	3 1/4 in.																	
QMF18J080S	80 mm																	
QMF18J085S	85 mm																	
QMF18J307S	3 7/16 in.																	
QMF18J308S	3 1/2 in.																	
QMF18J090S	90 mm																	
QMF20J311S	3 11/16 in.	22220	278.4	152.4	224.0	196.9	253.2	38.1	24	41.4	126.2	128.3	75.2	103.1	9.4	116.6	24.9	
QMF20J312S	3 3/4 in.		10.96	6.00	8.82	7.75	9.97	1.50	7/8	1.63	4.97	5.05	2.96	4.06	0.37	4.59	55	
QMF20J315S	3 15/16 in.																	
QMF20J400S	4 in.																	
QMF20J100S	100 mm	22222	314.5	160.0	256.8	222.3	276.4	38.1	24	46.5	150.1	152.1	94.0	106.9	9.7	140.5	28.6	
QMF22J110S	110 mm		12.38	6.30	10.11	8.75	10.88	1.50	7/8	1.83	5.91	5.99	3.70	4.21	0.38	5.53	63	
QMF22J407S	4 7/16 in.																	
QMF22J408S	4 1/2 in.																	
QMF22J115S	115 mm																	

QMFL FOUR-BOLT SQUARE FLANGE BLOCKS

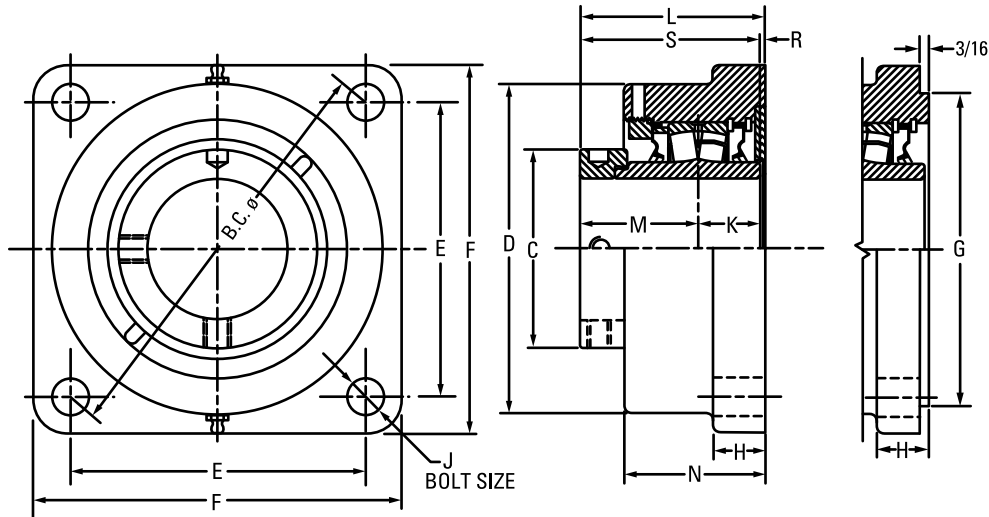

Bearing Part No.	Shaft Dia.	Bearing No.	B.C.	C	D	E	F	G ⁽¹⁾⁽²⁾⁽³⁾	H	J	K	L _{FIX}	L _{EXP}	M	N	R	S	Wt.
	mm in.		mm in.	mm in.	mm in.	mm in.	mm in.	mm in.	mm in.	mm in.	mm in.	mm in.	mm in.	mm in.	mm in.	mm in.	mm in.	kg lbs.
QMFL08J035S	35 mm																	
QMFL08J107S	1 7/16 in.	22208	127.0	60.5	93.7	89.9	117.6	N/A	22.4	12	25.4	72.9	74.9	44.5	57.2	3.0	69.9	4.5
QMFL08J108S	1 1/2 in.		5.00	2.38	3.69	3.54	4.63		0.88	1/2	1.00	2.87	2.95	1.75	2.25	0.12	2.75	10
QMFL09J111S	1 11/16 in.																	
QMFL09J040S	40 mm	22209	139.7	66.8	118.4	98.8	136.7	N/A	22.4	12	25.1	79.5	81.5	47.8	63.5	6.6	72.9	5.0
QMFL09J112S	1 3/4 in.		5.50	2.63	4.66	3.89	5.38		0.88	1/2	0.99	3.13	3.21	1.88	2.50	0.26	2.87	11
QMFL09J045S	45 mm																	
QMFL10J115S	1 15/16 in.																	
QMFL10J200S	2 in.	22210	146.1	70.1	115.3	103.4	131.8	N/A	23.1	12	24.9	80.8	82.8	48.0	62.5	7.9	72.9	5.0
QMFL10J050S	50 mm		5.75	2.76	4.54	4.07	5.19		0.91	1/2	0.98	3.18	3.26	1.89	2.46	0.31	2.87	11
QMFL11J203S	2 3/16 in.																	
QMFL11J204S	2 1/4 in.	22211	162.1	76.0	130.3	114.3	149.4	N/A	19.1	16	28.7	83.3	85.3	50.5	66.8	3.8	79.2	6.4
QMFL11J055S	55 mm		6.38	2.99	5.13	4.50	5.88		0.75	5/8	1.13	3.28	3.36	1.99	2.63	0.15	3.12	14
QMFL13J060S	60 mm																	
QMFL13J207S	2 7/16 in.	22213	171.5	91.9	146.1	121.2	157.2	N/A	25.4	16	31.5	88.9	90.7	54.1	72.6	3.0	85.6	7.7
QMFL13J208S	2 1/2 in.		6.75	3.62	5.75	4.77	6.19		1.00	5/8	1.24	3.50	3.57	2.13	2.86	0.12	3.37	17
QMFL13J065S	65 mm																	
QMFL15J211S	2 11/16 in.																	
QMFL15J212S	2 3/4 in.																	
QMFL15J070S	70 mm	22215	200.2	101.9	168.4	141.2	182.6	N/A	26.9	20	31.8	95.8	97.8	60.2	74.4	3.8	91.9	10.4
QMFL15J215S	2 15/16 in.		7.88	4.01	6.63	5.56	7.19		1.06	3/4	1.25	3.77	3.85	2.37	2.93	0.15	3.62	23
QMFL15J300S	3 in.																	
QMFL15J075S	75 mm																	
QMFL18J303S	3 3/16 in.																	
QMFL18J304S	3 1/4 in.																	
QMFL18J080S	80 mm	22218	241.3	120.9	193.8	170.7	212.9	187.33	32.5	20	36.6	106.4	108.5	65.8	86.4	4.1	102.4	15.9
QMFL18J085S	85 mm		9.50	4.76	7.63	6.72	8.38	7.375	1.28	3/4	1.44	4.19	4.27	2.59	3.40	0.16	4.03	35
QMFL18J307S	3 7/16 in.																	
QMFL18J308S	3 1/2 in.																	
QMFL18J090S	90 mm																	
QMFL20J311S	3 11/16 in.																	
QMFL20J312S	3 3/4 in.																	
QMFL20J315S	3 15/16 in.	22220	273.1	152.4	229.6	193.0	241.3	215.90	38.1	24	41.4	132.3	134.4	75.2	104.6	15.7	116.6	24.9
QMFL20J400S	4 in.		10.75	6.00	9.04	7.60	9.50	8.500	1.50	1	1.63	5.21	5.29	2.96	4.12	0.62	4.59	55
QMFL20J100S	100 mm																	

⁽¹⁾Pilot tolerance: +0/-0.05 mm (+0/-0.002 in.).

⁽²⁾Add (p) to the end of the housing designation in the part number to order with pilot using G dimension.

⁽³⁾Piloted flange blocks will be quoted (price and delivery) upon request. For optional spigot on flange side, insert the letter P as seen in the following example: QMFP**J***S.

QMFY ROUND FLANGE BLOCKS

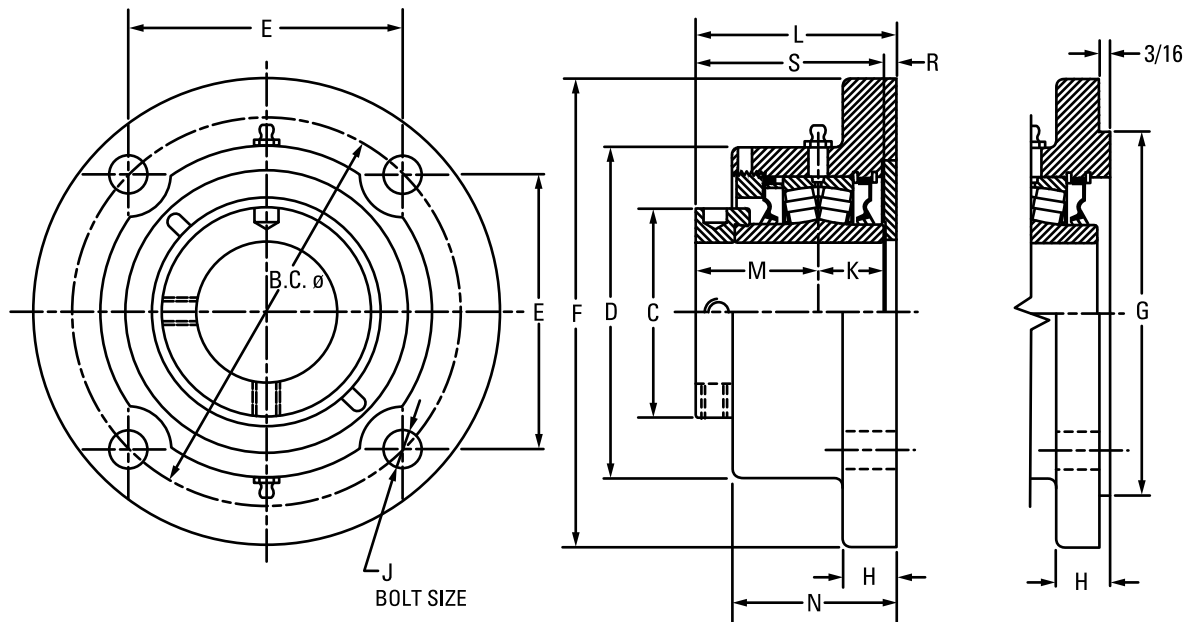

Bearing Part No.	Shaft Dia.	Bearing No.	B.C.	C	D	E	F	G ⁽¹⁾⁽²⁾⁽³⁾	H	J	K	L _{FIX}	L _{EXP}	M	N	R	S	Wt.
																		mm
QMFY08J035S ⁽⁴⁾	35 mm	22208	127.0 5.00 ⁽⁴⁾	60.5 2.38	108.0 4.25	88.9 3.54 ⁽⁴⁾	158.8 6.25	90.50 3.563	19.1 0.75	12 1/2 ⁽⁴⁾	25.4 1.00	73.2 2.88	75.2 2.96	44.5 1.75	57.4 2.26	3.3 0.13	69.9 2.75	4.5
QMFY08J107S ⁽⁴⁾	1 7/16 in.																	10
QMFY08J108S ⁽⁴⁾	1 1/2 in.																	10
QMFY09J040S	40 mm	22209	139.7 5.50	66.8 2.63	104.9 4.13	98.8 3.89	171.5 6.75	103.20 4.063	20.6 0.81	12 1/2	25.1 0.99	76.2 3.00	78.2 3.08	47.8 1.88	60.5 2.38	3.0 0.12	72.9 2.87	5.0
QMFY09J111S	1 11/16 in.																	11
QMFY09J112S	1 3/4 in.																	11
QMFY09J045S	45 mm	22210	146.1 5.75	70.1 2.76	115.3 4.54	98.8 3.89	171.5 6.75	111.13 4.375	19.1 0.75	12 1/2	24.9 0.98	75.9 2.99	78.0 3.07	48.0 1.89	58.4 2.30	3.0 0.12	72.9 2.87	5.4
QMFY10J115S	1 15/16 in.																	12
QMFY10J200S	2 in.																	12
QMFY10J050S	50 mm	22211	162.1 6.38	75.9 2.99	130.3 5.13	114.3 4.50	196.9 7.75	127.00 5.000	19.1 0.75	16 5/8	28.7 1.13	82.3 3.24	84.3 3.32	75.9 2.99	62.0 2.44	3.0 0.12	79.2 3.12	6.8
QMFY11J203S	2 3/16 in.																	15
QMFY11J204S	2 1/4 in.																	15
QMFY11J055S	55 mm	22213	171.5 6.75	91.9 3.62	146.1 5.75	121.2 4.77	206.5 8.13	138.13 5.438	23.9 0.94	16 5/8	31.5 1.24	88.1 3.47	90.4 3.56	54.1 2.13	72.4 2.85	2.3 0.09	85.6 3.37	8.6
QMFY13J207S	2 7/16 in.																	19
QMFY13J208S	2 1/2 in.																	19
QMFY13J065S	65 mm	22215	199.9 7.87	101.9 4.01	168.4 6.63	141.2 5.56	241.3 9.50	160.35 6.313	23.9 0.94	20 3/4	31.8 1.25	98.6 3.88	100.6 3.96	60.2 2.37	76.2 3.00	6.4 0.25	91.9 3.62	12.7
QMFY15J211S	2 11/16 in.																	28
QMFY15J212S	2 3/4 in.																	28
QMFY15J070S	70 mm																	
QMFY15J215S	2 15/16 in.																	
QMFY15J300S	3 in.																	
QMFY15J075S	75 mm																	

⁽¹⁾Pilot tolerance: +0/-0.05 mm (+0/-0.002 in.).

⁽²⁾Add (p) to the end of the housing designation in the part number to order with pilot using G dimension.

⁽³⁾Piloted flange blocks will be quoted (price and delivery) upon request. For optional spigot on flange side, insert the letter P as seen in the following example: QMFP**J***S.

⁽⁴⁾Three-bolt housing.

⁽⁵⁾Six-bolt housing.

NOTE: Housings also are available with a 3/16 in. machined pilot. Please contact your Timken engineer for more information.

Continued on next page.

QMFY ROUND FLANGE BLOCKS – continued

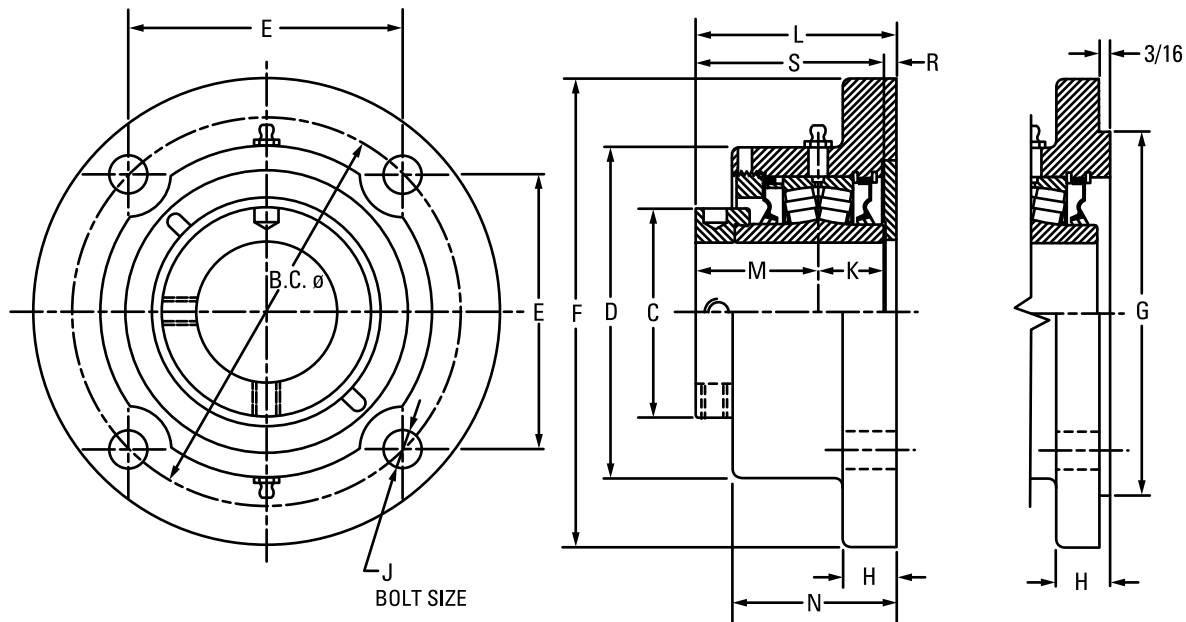

Continued from previous page.

Bearing Part No.	Shaft Dia.	Bearing No.	B.C.	C	D	E	F	G ⁽¹⁾⁽²⁾⁽³⁾	H	J	K	L _{FIX}	L _{EXP}	M	N	R	S	Wt.
	mm in.		mm in.	mm in.	mm in.	mm in.	mm in.	mm in.	mm in.	mm in.	mm in.	mm in.	mm in.	mm in.	mm in.	mm in.	mm in.	kg lbs.
QMFY18J303S	3 3/16 in.	22218	241.3 9.50	120.9 4.76	193.8 7.63	170.7 6.72	282.7 11.13	N/A	28.7 1.13	24 7/8	36.6 1.44	108.7 4.28	110.7 4.36	65.8 2.59	85.3 3.36	6.4 0.25	102.4 4.03	19.1 42
QMFY18J304S	3 1/4 in.																	
QMFY18J080S	80 mm																	
QMFY18J085S	85 mm																	
QMFY18J307S	3 7/16 in.																	
QMFY18J308S	3 1/2 in.																	
QMFY18J090S	90 mm	22220	273.1 10.75	152.4 6.00	212.9 8.38	193.0 7.60	320.8 12.63	N/A	28.7 1.13	24 1	41.4 1.63	123.7 4.87	125.7 4.95	75.2 2.96	96.8 3.81	6.9 0.27	116.6 4.59	29.9 66
QMFY20J311S	3 11/16 in.																	
QMFY20J312S	3 3/4 in.																	
QMFY20J315S	3 15/16 in.																	
QMFY20J400S	4 in.																	
QMFY20J100S	100 mm																	
QMFY22J110S ⁽⁵⁾	110 mm	22222	327.2 12.88 ⁽⁵⁾	160.0 6.30	254.0 10.00	163.6 6.44 ⁽⁵⁾	384.3 15.13	N/A	31.8 1.25	24 1 ⁽⁵⁾	46.5 1.83	143.5 5.65	145.5 5.73	94.0 3.70	100.3 3.95	3.0 0.12	140.5 5.53	46.3 102
QMFY22J407S ⁽⁵⁾	4 7/16 in.																	
QMFY22J408S ⁽⁵⁾	4 1/2 in.																	
QMFY22J115S ⁽⁵⁾	115 mm																	
QMFY26J125S ⁽⁵⁾	125 mm																	
QMFY26J415S ⁽⁵⁾	4 15/16 in.																	
QMFY26J500S ⁽⁵⁾	5 in.	22226	355.6 14.00 ⁽⁵⁾	175.0 6.89	284.2 11.19	177.8 7.00 ⁽⁵⁾	419.1 16.50	N/A	38.1 1.50	24 1 1/8 ⁽⁵⁾	58.7 2.31	170.2 6.70	172.2 6.78	94.7 3.73	138.4 5.45	16.8 0.66	153.4 6.04	52.2 115
QMFY26J130S ⁽⁵⁾	130 mm																	

⁽¹⁾Pilot tolerance: +0/-0.05 mm (+0/-0.002 in.).

⁽²⁾Add (p) to the end of the housing designation in the part number to order with pilot using G dimension.

⁽³⁾Piloted flange blocks will be quoted (price and delivery) upon request. For optional spigot on flange side, insert the letter P as seen in the following example: QMFP**J***S.

⁽⁴⁾Three-bolt housing.

⁽⁵⁾Six-bolt housing.

NOTE: Housings also are available with a 3/16 in. machined pilot. Please contact your Timken engineer for more information.

QMF5000 SERIES SQUARE FLANGE BLOCKS

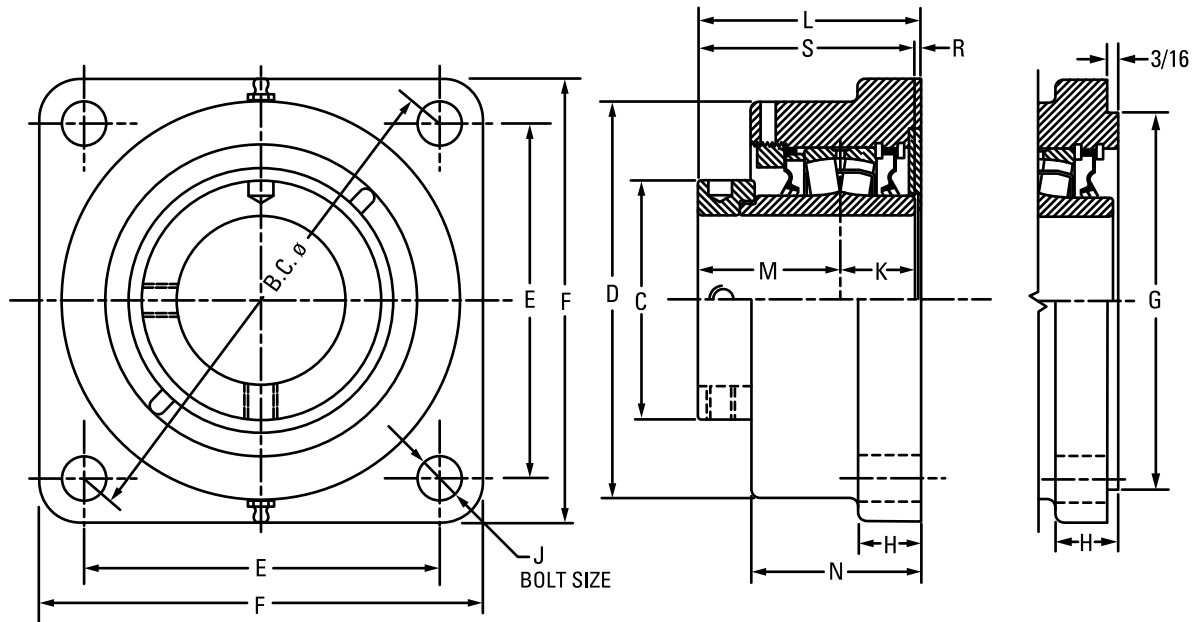

Bearing Part No.	Shaft Dia.	Bearing No.	B.C.	C	D	E	F	G ⁽¹⁾⁽²⁾⁽³⁾	H	J	K	L _{FIX}	L _{EXP}	M	N	R	S	Wt.														
																		mm	kg	lbs.												
QMF08J035S	35 mm	22208	133.6	59.9	93.7	94.5	117.6	90.50	22.1	12	25.4	72.9	74.9	44.5	57.2	3.0	69.9	4.5	10													
QMF08J107S	1 7/16 in.		5.26	2.36	3.69	3.72	4.63	3.563	0.88	1/2	1.00	2.87	2.95	1.75	2.25	0.12	2.75	10														
QMF08J108S	1 1/2 in.	22208	139.7	59.9	108.0	98.8	130.3	103.20	22.1	12	25.4	73.7	75.7	44.5	59.4	3.81	69.9	4.5	10													
QMF09J040S	40 mm	22209	139.7	66.8	108.0	98.8	130.3	103.20	22.1	12	25.1	79.5	81.5	47.8	63.5	6.4	72.9	5.0	11													
QMF09J111S	1 11/16 in.																	5.50	2.63	4.25	3.89	5.13	4.063	0.88	1/2	0.99	3.13	3.21	1.88	2.50	0.25	2.87
QMF09J112S	1 3/4 in.																	5.50	2.63	4.25	3.89	5.13	4.063	0.88	1/2	0.99	3.13	3.21	1.88	2.50	0.25	2.87
QMF09J045S	45 mm	22210	146.1	70.1	120.7	103.1	134.9	111.13	22.1	12	24.9	80.8	82.8	48.0	65.0	7.9	72.9	5.0	11													
QMF10J200S	2 in.																	5.75	2.76	4.75	4.06	5.31	4.375	0.88	1/2	0.98	3.18	3.26	1.89	2.56	0.31	2.87
QMF10J050S	50 mm																	5.75	2.76	4.75	4.06	5.31	4.375	0.88	1/2	0.98	3.18	3.26	1.89	2.56	0.31	2.87
QMF11J203S	2 3/16 in.	22211	161.5	75.9	130.3	114.3	149.4	127.00	25.4	16	28.7	83.1	85.1	50.5	66.8	3.3	79.2	5.0	11													
QMF11J204S	2 1/4 in.																	6.36	2.99	5.13	4.50	5.88	5.000	1.00	5/8	1.13	3.27	3.35	1.99	2.63	0.13	3.12
QMF11J055S	55 mm																	6.36	2.99	5.13	4.50	5.88	5.000	1.00	5/8	1.13	3.27	3.35	1.99	2.63	0.13	3.12
QMF13J060S	60 mm	22213	180.8	91.9	146.1	127.8	157.2	138.13	25.4	16	31.5	89.2	91.2	54.1	72.4	3.0	85.6	6.4	14													
QMF13J207S	2 7/16 in.																	7.12	3.62	5.75	5.03	6.19	5.438	1.00	5/8	1.24	3.51	3.59	2.13	2.85	0.12	3.37
QMF13J208S	2 1/2 in.																	7.12	3.62	5.75	5.03	6.19	5.438	1.00	5/8	1.24	3.51	3.59	2.13	2.85	0.12	3.37
QMF13J065S	65 mm	22215	215.9	102.1	168.9	152.7	189.0	160.35	26.9	20	31.8	96.0	98.0	60.2	76.2	4.1	91.9	7.7	17													
QMF15J211S	2 11/16 in.																	8.50	4.02	6.65	6.01	7.44	6.313	1.06	3/4	1.25	3.78	3.86	2.37	3.00	0.16	3.62
QMF15J212S	2 3/4 in.																	8.50	4.02	6.65	6.01	7.44	6.313	1.06	3/4	1.25	3.78	3.86	2.37	3.00	0.16	3.62
QMF15J070S	70 mm	22215	215.9	102.1	168.9	152.7	189.0	160.35	26.9	20	31.8	96.0	98.0	60.2	76.2	4.1	91.9	7.7	17													
QMF15J215S	2 15/16 in.																	8.50	4.02	6.65	6.01	7.44	6.313	1.06	3/4	1.25	3.78	3.86	2.37	3.00	0.16	3.62
QMF15J300S	3 in.																	8.50	4.02	6.65	6.01	7.44	6.313	1.06	3/4	1.25	3.78	3.86	2.37	3.00	0.16	3.62
QMF15J075S	75 mm	22215	215.9	102.1	168.9	152.7	189.0	160.35	26.9	20	31.8	96.0	98.0	60.2	76.2	4.1	91.9	7.7	17													

⁽¹⁾Pilot tolerance: +0/-0.05 mm (+0/-0.002 in.).

⁽²⁾Add (p) to the end of the housing designation in the part number to order with pilot using G dimension.

⁽³⁾Piloted flange blocks will be quoted (price and delivery) upon request. For optional spigot on flange side, insert the letter P as seen in the following example: QMFP**J***S.

⁽⁴⁾Six-bolt round housing.

Continued on next page.

QMF 5000 SERIES SQUARE FLANGE BLOCKS – continued

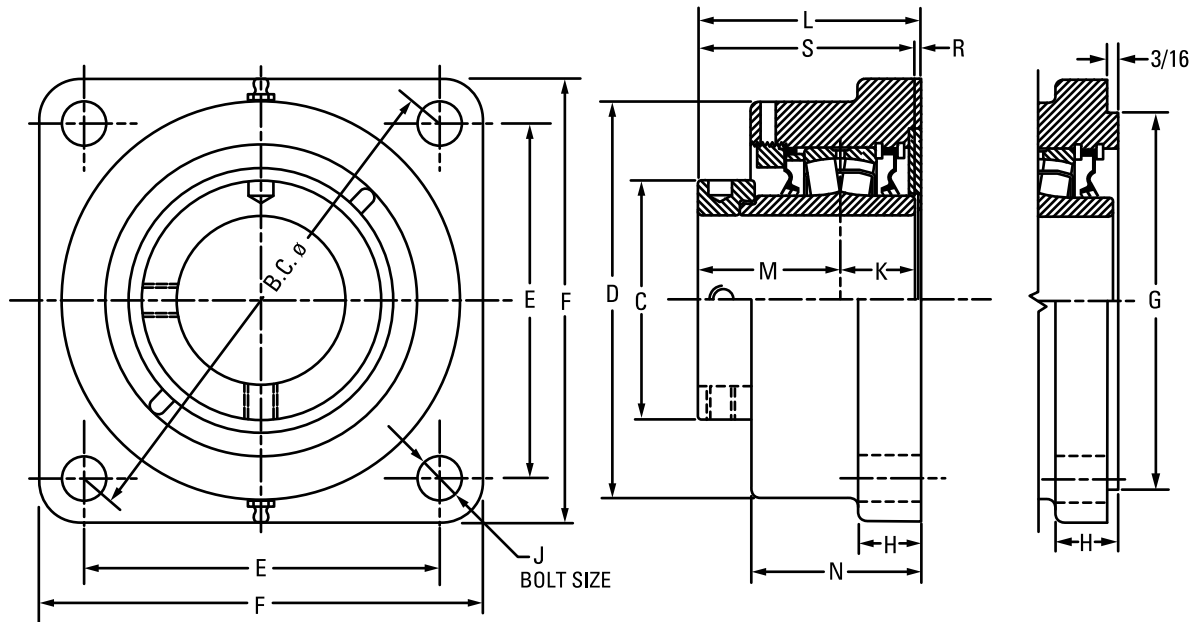

Continued from previous page.

Bearing Part No.	Shaft Dia.	Bearing No.	B.C.	C	D	E	F	G ⁽¹⁾⁽²⁾⁽³⁾	H	J	K	L _{FIX}	L _{EXP}	M	N	R	S	Wt.
	mm in.		mm in.	mm in.	mm in.	mm in.	mm in.	mm in.	mm in.	mm in.	mm in.	mm in.	mm in.	mm in.	mm in.	mm in.	mm in.	kg lbs.
QMF18J303S	3 3/16 in.	22218	241.3 9.50	120.9 4.76	193.8 7.63	170.7 6.72	212.9 8.38	187.33 7.375	33.3 1.31	20 3/4	36.6 1.44	107.2 4.22	109.2 4.30	65.8 2.59	84.1 3.31	4.8 0.19	102.4 4.03	10.4 23
QMF18J304S	3 1/4 in.																	
QMF18J080S	80 mm																	
QMF18J085S	85 mm																	
QMF18J307S	3 7/16 in.																	
QMF18J308S	3 1/2 in.																	
QMF18J090S	90 mm	22220	298.5 11.75	152.4 6.00	215.9 8.50	211.1 8.31	268.2 10.56	225.43 8.875	38.1 1.50	24 7/8	41.4 1.63	126.0 4.96	128.0 5.04	75.2 2.96	103.1 4.06	9.4 0.37	116.8 4.60	15.9 35
QMF20J311S	3 11/16 in.																	
QMF20J312S	3 3/4 in.																	
QMF20J315S	3 15/16 in.																	
QMF20J400S	4 in.																	
QMF20J100S	100 mm																	
QMF22J110S ⁽⁴⁾	110 mm	22222	327.2 12.88 ⁽¹⁾	160.0 6.30	256.5 10.10	163.6 6.44 ⁽¹⁾	384.3 15.13	263.53 10.375	31.8 1.25	24 1 ⁽¹⁾	46.5 1.83	143.8 5.66	145.8 5.74	94.0 3.70	106.9 4.21	3.3 0.13	140.5 5.53	46.3 102
QMF22J407S ⁽⁴⁾	4 7/16 in.																	
QMF22J408S ⁽⁴⁾	4 1/2 in.																	
QMF22J115S ⁽⁴⁾	115 mm																	
QMF26J125S ⁽⁴⁾	125 mm	22226	355.6 14.00 ⁽¹⁾	175.0 6.89	284.2 11.19	177.8 7.00 ⁽¹⁾	419.1 16.50	284.18 11.188	38.1 1.50	24 1 1/8 ⁽¹⁾	58.7 2.31	172.2 6.78	174.2 6.86	94.7 3.73	135.1 5.32	17.3 0.68	153.4 6.04	52.2 115
QMF26J415S ⁽⁴⁾	4 15/16 in.																	
QMF26J500S ⁽⁴⁾	5 in.																	
QMF26J130S ⁽⁴⁾	130 mm																	

⁽¹⁾Pilot tolerance: +0/-0.05 mm (+0/-0.002 in.).

⁽²⁾Add (p) to the end of the housing designation in the part number to order with pilot using G dimension.

⁽³⁾Piloted flange blocks will be quoted (price and delivery) upon request. For optional spigot on flange side, insert the letter P as seen in the following example: QMFP**J***S.

⁽⁴⁾Six-bolt round housing.

QMTU TAKE-UP BLOCKS

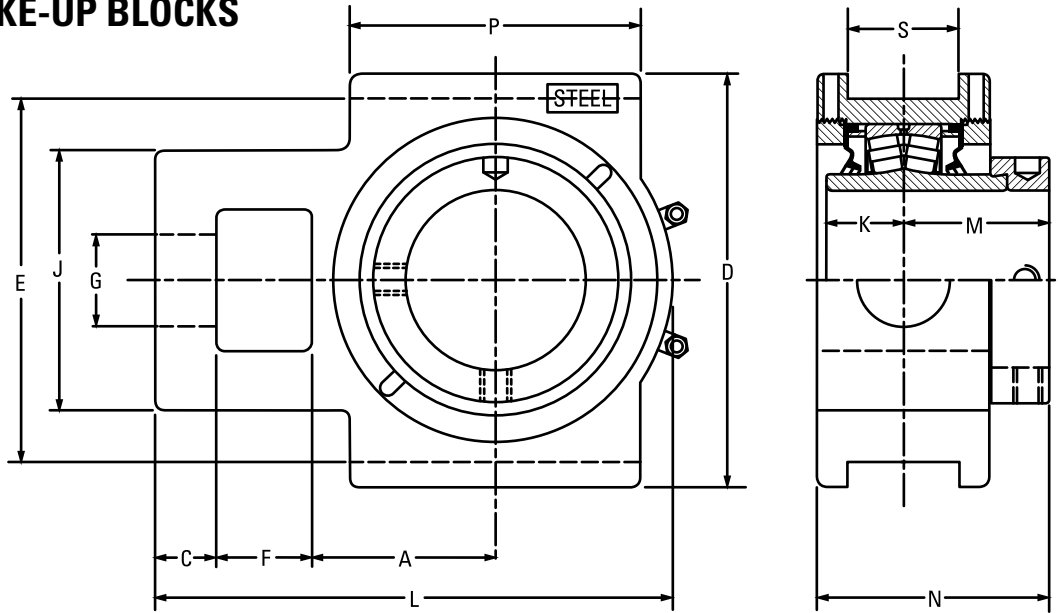

Bearing Part No.	Shaft Dia.	Bearing No.	A	C	D	E	F	G	J	K	L	M	N	P	S	Wt.
			mm in.	mm in.	mm in.	mm in.	mm in.	mm in.	mm in.	mm in.	mm in.	mm in.	mm in.	mm in.	mm in.	mm in.
QMTU10J115S	1 15/16 in.	22210	54.1	19.1	120.7	101.6	26.9	26.9	73.2	24.9	153.4	48.0	76.7	88.9	17.5	7.7
QMTU10J200S	2 in.		2.13	0.75	4.75	4.00	1.06	1.06	2.88	0.98	6.04	1.89	3.02	3.50	0.69	17
QMTU10J050S	50 mm															
QMTU11J203S	2 3/4 in.	22211	60.5	19.1	133.4	114.3	30.2	30.2	88.9	28.7	167.9	50.5	82.8	95.3	20.6	9.5
QMTU11J204S	2 1/4 in.		2.38	0.75	5.25	4.50	1.19	1.19	3.50	1.13	6.61	1.99	3.26	3.75	0.81	21
QMTU11J055S	55 mm															
QMTU13J060S	60 mm	22213	69.9	22.4	149.4	130.3	33.3	33.3	95.3	31.5	193.8	54.1	90.7	120.7	26.9	12.2
QMTU13J207S	2 7/16 in.		2.75	0.88	5.88	5.13	1.31	1.31	3.75	1.24	7.63	2.13	3.57	4.75	1.06	27
QMTU13J208S	2 1/2 in.															
QMTU13J065S	65 mm	22215	76.2	25.4	171.5	150.9	39.6	39.6	108.0	31.8	219.7	60.2	97.0	120.7	46.0	15.9
QMTU15J211S	2 11/16 in.		3.00	1.00	6.75	5.94	1.56	1.56	4.25	1.25	8.65	2.37	3.82	4.75	1.81	35
QMTU15J212S	2 3/4 in.															
QMTU15J070S	70 mm	22218	92.2	25.4	193.8	173.0	46.0	47.8	124.0	36.6	257.0	65.8	106.4	158.8	46.0	20.0
QMTU18J303S	3 3/16 in.		3.63	1.00	7.63	6.81	1.81	1.88	4.88	1.44	10.12	2.59	4.19	6.25	1.81	44
QMTU18J304S	3 1/4 in.															
QMTU18J080S	80 mm	22220	104.9	28.7	239.8	219.2	54.1	52.3	143.0	41.4	296.9	75.4	120.4	177.8	52.3	26.3
QMTU18J085S	85 mm		4.13	1.13	9.44	8.63	2.13	2.06	5.63	1.63	11.69	2.97	4.74	7.00	2.06	58
QMTU18J307S	3 7/16 in.															
QMTU18J308S	3 1/2 in.	22222	128.5	38.1	263.7	241.3	54.1	54.1	162.1	46.5	341.4	94.0	143.8	199.9	52.3	36.4
QMTU18J090S	90 mm		5.06	1.50	10.38	9.50	2.13	2.13	6.38	1.83	13.44	3.70	5.66	7.87	2.06	80
QMTU20J311S	3 11/16 in.															
QMTU20J312S	3 3/4 in.	22226	134.9	63.5	285.8	260.4	63.5	60.5	177.8	58.7	396.7	94.7	151.1	228.6	52.3	60.8
QMTU20J315S	3 15/16 in.		4.13	2.50	11.25	10.25	2.50	2.38	7.00	2.31	15.62	3.73	5.95	9.00	2.06	134
QMTU20J400S	4 in.															
QMTU20J100S	100 mm	22226	134.9	63.5	285.8	260.4	63.5	60.5	177.8	58.7	396.7	94.7	151.1	228.6	52.3	60.8
QMTU22J110S	110 mm		5.31	2.50	11.25	10.25	2.50	2.38	7.00	2.31	15.62	3.73	5.95	9.00	2.06	134
QMTU22J407S	4 7/16 in.															
QMTU22J408S	4 1/2 in.	22226	134.9	63.5	285.8	260.4	63.5	60.5	177.8	58.7	396.7	94.7	151.1	228.6	52.3	60.8
QMTU22J115S	115 mm		5.31	2.50	11.25	10.25	2.50	2.38	7.00	2.31	15.62	3.73	5.95	9.00	2.06	134
QMTU26J125S	125 mm															
QMTU26J415S	4 15/16 in.	22226	134.9	63.5	285.8	260.4	63.5	60.5	177.8	58.7	396.7	94.7	151.1	228.6	52.3	60.8
QMTU26J500S	5 in.		5.31	2.50	11.25	10.25	2.50	2.38	7.00	2.31	15.62	3.73	5.95	9.00	2.06	134
QMTU26J130S	130 mm															

NOTE: Please refer to page 177 for take-up frames.

QMMC CARTRIDGE BLOCKS

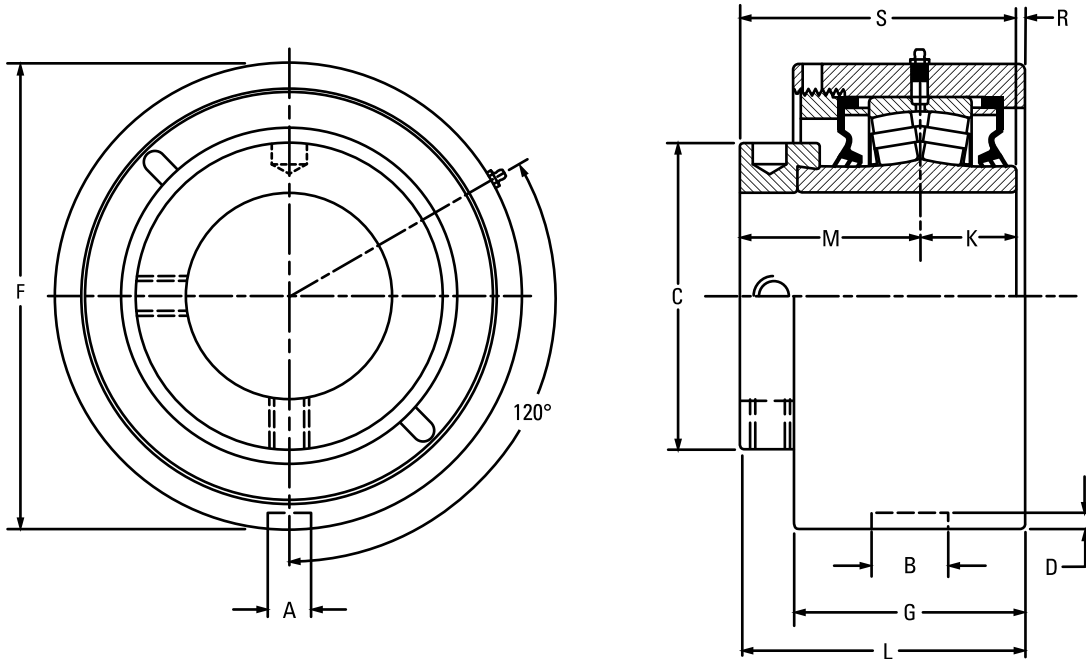

Bearing Part No.	Shaft Dia.	Bearing No.	A	B	C	D	F	G	K	L FIX	L EXP	M	R	S	Wt.
	mm in.		mm in.	mm in.	mm in.	mm in.	mm in.	mm in.	mm in.	mm in.	mm in.	mm in.	mm in.	mm in.	kg lbs.
QMMC10J115S	1 15/16 in.	22210	13.5 0.53	23.1 0.91	70.1 2.76	4.8 0.19	104.78 (+0/-0.05) 4.125 (+0/-0.002)	62.2 2.45	24.9 0.98	79.2 3.12	81.3 3.20	48.0 1.89	6.1 0.24	72.9 2.87	3.6 8
QMMC10J200S	2 in.														
QMMC10J050S	50 mm														
QMMC11J203S	2 3/16 in.	22211	13.5 0.53	23.1 0.91	75.9 2.99	4.8 0.19	115.09 (+0/-0.05) 4.531 (+0/-0.002)	65.5 2.58	28.7 1.13	83.6 3.29	85.6 3.37	50.5 1.99	4.1 0.16	79.2 3.12	4.5 10
QMMC11J204S	2 1/4 in.														
QMMC11J055S	55 mm														
QMMC13J060S ⁽¹⁾	60 mm	22213	13.5 0.53	23.1 0.91	91.9 3.62	4.8 0.19	127.00 (+0/-0.05) 5.000 (+0/-0.002)	69.3 2.73	31.5 1.24	85.6 3.37	87.6 3.45	54.1 2.13	0.0 0.00	85.6 3.37	5.4 12
QMMC13J207S ⁽¹⁾	2 7/16 in.														
QMMC13J208S ⁽¹⁾	2 1/2 in.														
QMMC13J065S ⁽¹⁾	65 mm														
QMMC15J211S	2 11/16 in.	22215	15.0 0.59	26.2 1.03	101.9 4.01	6.4 0.25	149.225 (+0/-0.05) 5.875 (+0/-0.002)	79.8 3.14	31.8 1.25	100.1 3.94	102.1 4.02	60.2 2.37	8.1 0.32	91.9 3.62	8.2 18
QMMC15J212S	2 3/4 in.														
QMMC15J070S	70 mm														
QMMC15J215S	2 15/16 in.														
QMMC15J300S	3 in.														
QMMC15J075S	75 mm	22218	15.0 0.59	26.9 1.06	120.9 4.76	5.8 0.23	171.45 (+0/-0.05) 6.750 (+0/-0.002)	87.6 3.45	36.6 1.44	109.7 4.32	111.8 4.40	65.0 2.56	7.4 0.29	102.4 4.03	11.8 26
QMMC18J303S	3 3/16 in.														
QMMC18J304S	3 1/4 in.														
QMMC18J080S	80 mm														
QMMC18J085S	85 mm														
QMMC18J307S	3 7/16 in.														
QMMC18J308S	3 1/2 in.														
QMMC18J090S	90 mm	22220	19.8 0.78	32.5 1.28	152.4 6.00	7.9 0.31	206.375 (+0/-0.05) 8.125 (+0/-0.002)	105.2 4.14	41.4 1.63	128.0 5.039	130.0 5.12	75.2 2.96	11.4 0.45	116.6 4.59	14.5 32
QMMC20J311S	3 11/16 in.														
QMMC20J312S	3 3/4 in.														
QMMC20J315S	3 15/16 in.														
QMMC20J400S	4 in.														
QMMC20J100S	100 mm														

⁽¹⁾The grub screw is located in the external housing nut to secure to the housing.

Continued on next page.

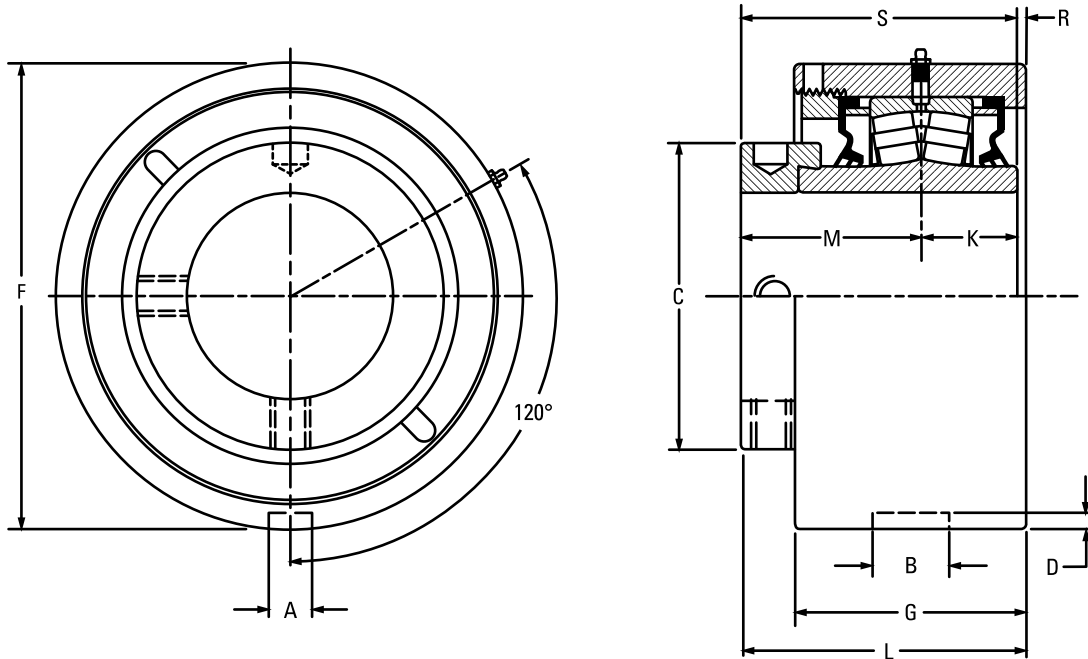

Continued from previous page.

Bearing Part No.	Shaft Dia.	Bearing No.	A	B	C	D	F	G	K	L FIX	L EXP	M	R	S	Wt.		
	mm in.		mm in.	mm in.	mm in.	mm in.	mm in.	mm in.	mm in.	mm in.	mm in.	mm in.	mm in.	mm in.	kg lbs.		
QMMC22J110S	110 mm	22222	19.8 0.78	38.1 1.50	160.0 6.30	7.9 0.31	222.25	108.5 4.27	46.5 1.83	148.0 5.83	150.1 5.91	94.0 3.70	7.6 0.30	140.5 5.53	18.1 40		
QMMC22J407S	4 7/16 in.						(+0/-0.08)									8.75	(+0/-0.003)
QMMC22J408S	4 1/2 in.																
QMMC22J115S	115 mm																
QMMC26J125S	125 mm	22226	19.8 0.78	38.1 1.50	175.0 6.89	7.9 0.31	265.13	141.7 5.58	58.7 2.31	165.4 6.51	167.4 6.59	94.7 3.73	11.9 0.47	153.4 6.04	31.8 70		
QMMC26J415S	4 15/16 in.						(+0/-0.08)									10.438	(+0/-0.003)
QMMC26J500S	5 in.																
QMMC26J130S	130 mm																
QMMC30J507S	5 7/16 in.	23230	19.8 0.78	38.1 1.50	205.0 8.07	5.6 0.22	292.10	154.4 6.08	75.9 2.99	188.2 7.41	190.2 7.49	116.1 4.57	-3.8 -0.15	192.0 7.56	88.0 194		
QMMC30J508S	5 1/2 in.						(+0/-0.08)									11.500	(+0/-0.003)
QMMC30J140S	140 mm																
QMMC30J515S	5 15/16 in.																
QMMC30J600S	6 in.	23230	19.8 0.78	38.1 1.50	205.0 8.07	5.6 0.22	311.15	154.4 6.08	75.9 2.99	188.2 7.41	190.2 7.49	116.1 4.57	-3.8 -0.15	192.0 7.56	87.1 192		
QMMC30J150S	150 mm						(+0/-0.08)									12.250	(+0/-0.003)
QMMC34J607S	6 7/16 in.																
QMMC34J608S	6 1/2 in.																
QMMC34J170S	170 mm	23234	19.8 0.78	38.1 1.50	235.0 9.25	5.6 0.22	344.50	181.1 7.13	85.1 3.35	219.5 8.64	221.5 8.72	129.0 5.08	5.33 0.21	214.1 8.43	155.6 343		
QMMC34J615S	6 15/16 in.						(+0/-0.08)									13.563	(+0/-0.003)
QMMC34J700S	7 in.																
QMMC34J180S	180 mm																

⁽¹⁾The grub screw is located in the external housing nut to secure to the housing.

QMMH HANGER BLOCKS

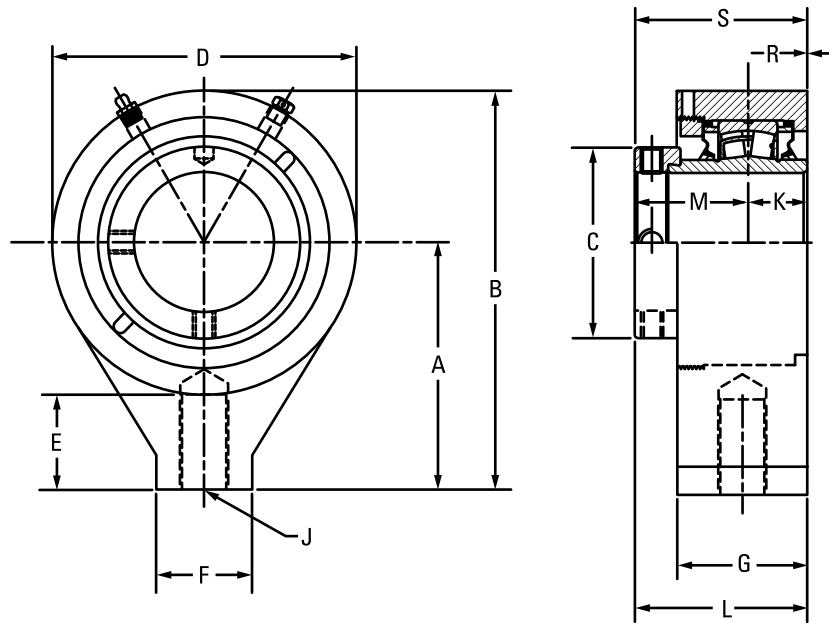

Bearing Part No.	Shaft Dia.	Bearing No.	A	B	C	D	E	F	G	J	K	L	M	R	S	Wt.
	mm in.		mm in.	mm in.	mm in.	mm in.	mm in.	mm in.	mm in.	in.	mm in.	mm in.	mm in.	mm in.	mm in.	kg lbs.
QMMH15J211S	2 11/16 in.	22215	131.8 5.19	212.9 8.38	101.9 4.01	162.1 6.38	50.8 2.00	50.8 2.00	69.9 2.75	1 -8UNC	31.8 1.25	91.9 3.62	60.2 2.37	0.0 0.00	91.9 3.62	10.0 22
QMMH15J212S	2 3/4 in.															
QMMH15J070S	70 mm															
QMMH15J215S	2 15/16 in.															
QMMH15J300S	3 in.															
QMMH15J075S	75 mm	22218	160.3 6.31	260.4 10.25	120.9 4.76	200.2 7.88	63.5 2.50	76.2 3.00	76.2 3.00	1 1/4 -7UNC	36.6 1.44	99.3 3.91	65.8 2.59	3.0 0.12	102.4 4.03	16.3 36
QMMH18J303S	3 3/16 in.															
QMMH18J304S	3 1/4 in.															
QMMH18J080S	80 mm															
QMMH18J085S	85 mm															
QMMH18J307S	3 7/16 in.															
QMMH18J308S	3 1/2 in.															
QMMH18J090S	90 mm															

TA/DV SERIES

The TA and DV series feature a 2300-series tapered adapter sleeve for increased shaft contact. This design offers the best shaft concentricity and highest capacity all the while having the ability to accommodate undersized shafting.

TA Series

TA series housed unit bearings are a direct drop-in replacement for SAF/SN split-cap housing dimensions.

DV Series

DV series housed units are a drop-in replacement for common American set screw mounted units.



Fig. 48. TA/DV series taper adapter insert.

YOU HAVE CHOICES

For the TA and DV series, you can select from many seal options and housing styles, which are shown on page 65.

HOUSINGS

- Two-bolt pillow blocks.
- Four-bolt pillow blocks.
- Flange blocks.
- Piloted flange cartridges.
- Cartridge blocks.

SEALS

- Labyrinth: DuPont Teflon (T).
- Triple-lip: nitrile rubber (M), urethane (O) and DuPont Viton (N).
- Double-lip: nitrile rubber (B) and DuPont Viton (C).
- Steel and urethane closed-end covers (CS).
- Steel and urethane open-end covers (CK) with:
 - DuPont Teflon (T).
 - Triple-lip seal (DR).
 - V-ring seal (VR).

TA/DV SERIES

	Housing Type	Primary Seals						Secondary Seals and Covers						
		M	N	O	B	C	T	Open-End Cover			Closed-End Cover	HSY Flange Cartridge Backing Plate		UFP Backing Plate
								DR	VR	T		DR		
V-Lock (Timken Exclusive Double Taper Lock)	Pillow Block	•	•	•	•	•	•	•	•	•	•	•		
	Flange Block	•	•	•	•	•	•	•	•	•	•	•		
	Piloted Flange Cartridge	•	•	•	•	•	•	•	•	•	•	•		
	Take-Up Block	•	•	•	•	•	•	•	•	•	•	•		
	Cartridge Block	•	•	•	•	•	•	•	•	•	•	•		
CL Series (Set Screw Lock)	Pillow Block	•	•	•	•	•	•	•	•	•	•	•		
	Flange Block	•	•	•	•	•	•	•	•	•	•	•		•
	Piloted Flange Cartridge	•	•	•	•	•	•	•	•	•	•	•	•	
	Take-Up Block	•	•	•	•	•	•	•	•	•	•	•		
	Cartridge Block	•	•	•	•	•	•	•	•	•	•	•		
	Hanger Block	•	•	•	•	•	•	•	•	•	•	•		
EC Series (Eccentric Lock)	Pillow Block	•	•	•	•	•	•	•	•	•	•	•		
	Flange Block	•	•	•	•	•	•	•	•	•	•	•		•
	Piloted Flange Cartridge	•	•	•	•	•	•	•	•	•	•	•	•	
	Take-Up Block	•	•	•	•	•	•	•	•	•	•	•		
	Cartridge Block	•	•	•	•	•	•	•	•	•	•	•		
	Hanger Block	•	•	•	•	•	•	•	•	•	•	•		
TA Series (Tapered Adapter Lock)	Pillow Block	•	•	•	•	•	•	•	•	•	•	•		
	Flange Block	•	•	•	•	•	•	•	•	•	•	•		
	Piloted Flange Cartridge	•	•	•	•	•	•	•	•	•	•	•		
	Cartridge Block	•	•	•	•	•	•	•	•	•	•	•		
DV Series (Tapered Adapter Lock)	Pillow Block	•	•	•	•	•	•	•	•	•	•	•		
	Flange Block	•	•	•	•	•	•	•	•	•	•	•		
	Piloted Flange Cartridge	•	•	•	•	•	•	•	•	•	•	•		

DVP TWO-BOLT PILLOW BLOCKS

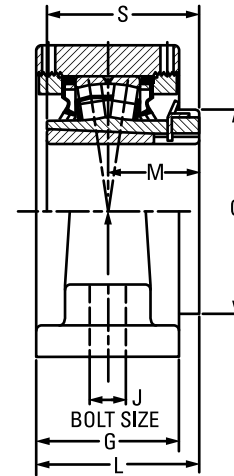
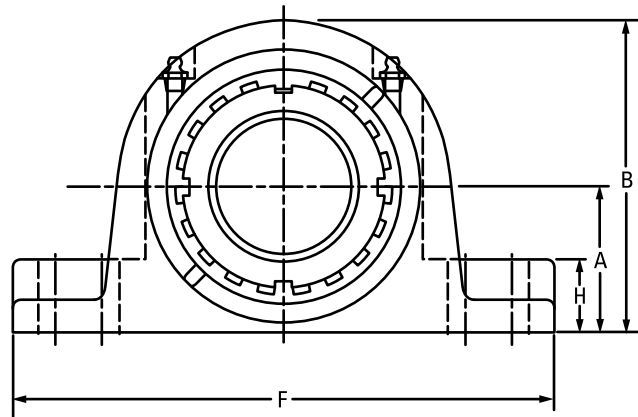
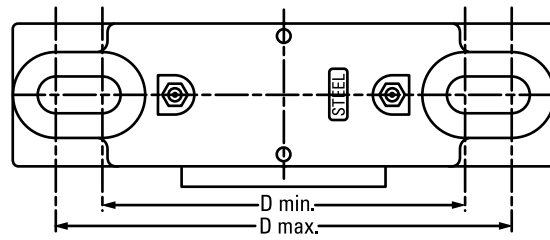

Bearing Part No.	Shaft Dia.	Bearing No.	A	B	C	D min.	D max.	F	G	H	J	L	M	S	Wt.
	mm in.		mm in.	mm in.	mm in.	mm in.	mm in.	mm in.	mm in.	mm in.	mm in.	mm in.	mm in.	mm in.	kg lbs.
DVP09K107S	1 7/16 in.	22209	47.8 1.88	98.6 3.88	65.0 2.56	119.1 4.69	152.4 6.00	174.8 6.88	53.3 2.10	25.4 1.00	12 1/2	57.4 2.26	30.7 1.21	50.3 1.98	4.5 10
DVP09K108S	1 1/2 in.	22209	54.1	104.9	65.0	119.1	165.1	200.2	53.3	25.4	12	57.4	30.7	50.3	4.5
DVP09K040S	40 mm		2.13	4.13	2.56	4.69	6.50	7.88	2.10	1.00	1/2	2.26	1.21	1.98	10
DVP10K111S	1 11/16 in.	22210	54.1 2.13	114.3 4.50	70.1 2.76	144.8 5.70	165.1 6.50	200.2 7.88	54.9 2.16	31.8 1.25	12 1/2	61.0 2.40	33.5 1.32	55.1 2.17	5.0 11
DVP10K112S	1 3/4 in.	22210	57.2	117.3	70.1	158.8	180.8	225.6	54.9	31.8	16	61.0	33.5	55.1	5.0
DVP10K045S	45 mm		2.25	4.62	2.76	6.25	7.12	8.88	2.16	1.25	5/8	2.40	1.32	2.17	11
DVP11K115S	1 15/16 in.	22211	57.2	123.4	74.9	152.4	181.1	225.6	61.7	31.8	16	66.5	35.6	58.9	5.9
DVP11K200S	2 in.		2.25	4.86	2.95	6.00	7.13	8.88	2.43	1.25	5/8	2.62	1.40	2.32	13
DVP11K050S	50 mm		2.25	4.86	2.95	6.00	7.13	8.88	2.43	1.25	5/8	2.62	1.40	2.32	13
DVP13K203S	2 3/16 in.	22213	63.5	138.9	85.1	165.1	200.0	244.6	70.6	32.8	16	74.9	39.6	65.0	9.1
DVP13K204S	2 1/4 in.		2.50	5.47	3.35	6.50	7.87	9.63	2.78	1.29	5/8	2.95	1.56	2.56	20
DVP13K060S	60 mm		2.50	5.47	3.35	6.50	7.87	9.63	2.78	1.29	5/8	2.95	1.56	2.56	20
DVP15K207S	2 7/16 in.	22215	69.9	149.9	98.0	174.8	219.2	260.4	68.6	35.1	16	78.2	43.9	73.4	11.3
DVP15K208S	2 1/2 in.		2.75	5.90	3.86	6.88	8.63	10.25	2.70	1.38	5/8	3.08	1.73	2.89	25
DVP15K065S	65 mm		2.75	5.90	3.86	6.88	8.63	10.25	2.70	1.38	5/8	3.08	1.73	2.89	25
DVP17K215S	2 15/16 in.	22217	82.6	173.2	110.0	200.2	244.3	295.4	76.2	35.1	20	88.1	49.8	82.0	14.5
DVP17K300S	3 in.		3.25	6.82	4.33	7.88	9.62	11.63	3.00	1.38	3/4	3.47	1.96	3.23	32
DVP17K075S	75 mm		3.25	6.82	4.33	7.88	9.62	11.63	3.00	1.38	3/4	3.47	1.96	3.23	32
DVP20K307S	3 7/16 in.	22220	95.3	202.7	130.0	238.3	285.8	342.9	85.9	47.8	24	101.3	58.4	97.0	25.9
DVP20K308S	3 1/2 in.		3.75	7.98	5.12	9.38	11.25	13.50	3.38	1.88	7/8	3.99	2.30	3.82	57
DVP20K090S	90 mm		3.75	7.98	5.12	9.38	11.25	13.50	3.38	1.88	7/8	3.99	2.30	3.82	57
DVP22K315S	3 15/16 in.	22222	108.0	223.5	145.0	255.5	317.5	362.0	100.6	38.1	24	113.3	63.0	104.9	30.4
DVP22K400S	4 in.		4.25	8.80	5.71	10.06	12.50	14.25	3.96	1.50	1	4.46	2.48	4.13	67
DVP22K100S	100 mm		4.25	8.80	5.71	10.06	12.50	14.25	3.96	1.50	1	4.46	2.48	4.13	67

TAPA SAF-STYLE TWO-BOLT PILLOW BLOCKS

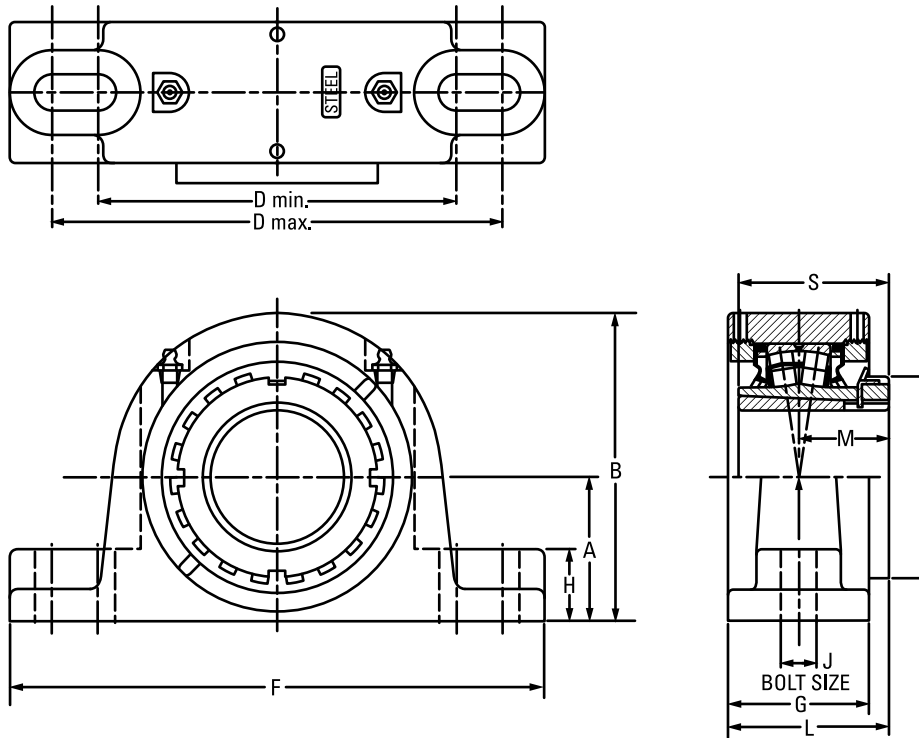

Bearing Part No.	Shaft Dia.	Bearing No.	A	B	C	D min.	D max.	F	G	H	J	L	M	S	Wt.
	mm in.		mm in.	mm in.	mm in.	mm in.	mm in.	mm in.	mm in.	mm in.	mm in.	mm in.	mm in.	mm in.	kg lbs.
TAPA09K107S	1 7/16 in.	22209	57.2	108.0	65.0	158.8	177.8	209.6	53.3	29.0	12	57.4	30.7	50.3	4.5
TAPA09K108S	1 1/2 in.		2.25	4.25	2.56	6.25	7.00	8.25	2.10	1.14	1/2	2.26	1.21	1.98	10
TAPA09K040S	40 mm														
TAPA10K111S	1 11/16 in.	22210	63.5	123.7	70.1	165.1	177.8	209.6	54.9	31.8	12	61.0	33.5	55.1	5.9
TAPA10K112S	1 3/4 in.		2.50	4.87	2.76	6.50	7.00	8.25	2.16	1.25	1/2	2.40	1.32	2.17	13
TAPA10K045S	45 mm														
TAPA11K115S	1 15/16 in.	22211	69.9	135.4	74.9	165.1	221.0	251.0	60.5	31.8	16	65.8	35.6	58.9	7.7
TAPA11K200S	2 in.		2.75	5.33	2.95	6.50	8.70	9.88	2.38	1.25	5/8	2.59	1.40	2.32	17
TAPA11K050S	50 mm														
TAPA13K203S	2 3/16 in.	22213	76.2	151.1	85.1	182.9	241.3	269.5	68.6	31.2	16	73.9	39.6	65.0	10.4
TAPA13K204S	2 1/4 in.		3.00	5.95	3.35	7.20	9.50	10.61	2.70	1.23	5/8	2.91	1.56	2.56	23
TAPA13K060S	60 mm														
TAPA15K207S	2 7/16 in.	22215	82.6	163.3	98.0	200.2	244.6	276.4	68.6	31.8	16	78.2	43.9	72.9	12.2
TAPA15K208S	2 1/2 in.		3.25	6.43	3.86	7.88	9.63	10.88	2.70	1.25	5/8	3.08	1.73	2.87	27
TAPA15K065S	65 mm														
TAPA17K215S	2 15/16 in.	22217	95.3	185.9	110.0	241.3	279.4	320.8	76.2	33.8	20	88.1	49.8	82.0	15.0
TAPA17K300S	3 in.		3.75	7.32	4.33	9.50	11.00	12.63	3.00	1.33	3/4	3.47	1.96	3.23	33
TAPA17K075S	75 mm														
TAPA20K307S	3 7/16 in.	22220	114.3	219.2	130.0	276.4	333.5	374.7	86.9	41.4	24	102.4	58.4	97.0	29.5
TAPA20K308S	3 1/2 in.		4.50	8.63	5.12	10.88	13.13	14.75	3.42	1.63	7/8	4.03	2.30	3.82	65
TAPA20K090S	90 mm														
TAPA22K315S	3 15/16 in.	22222	125.5	240.5	145.0	317.5	368.3	406.4	100.6	50.8	24	113.5	63.0	104.9	38.1
TAPA22K400S	4 in.		4.94	9.47	5.71	12.50	14.50	16.00	3.96	2.00	7/8	4.47	2.48	4.13	84
TAPA22K100S	100 mm														
TAPA26K407S	4 7/16 in.	22226	152.4	284.0	165.1	362.0	400.1	444.5	128.0	51.8	24	135.9	71.9	120.9	61.7
TAPA26K408S	4 1/2 in.		6.00	11.18	6.50	14.25	15.75	17.50	5.04	2.04	1	5.35	2.83	4.76	136
TAPA26K115S	115 mm														
TAPA28K415S	4 15/16 in.	22228	152.4	290.8	180.1	384.3	441.5	499.9	108.0	51.8	30	120.4	77.5	131.1	61.8
TAPA28K500S	5 in.		6.00	11.45	7.09	15.13	17.38	19.68	4.25	2.04	1 1/4	4.74	3.05	5.16	136
TAPA28K125S	125 mm														

TAPN SN-STYLE TWO-BOLT PILLOW BLOCKS

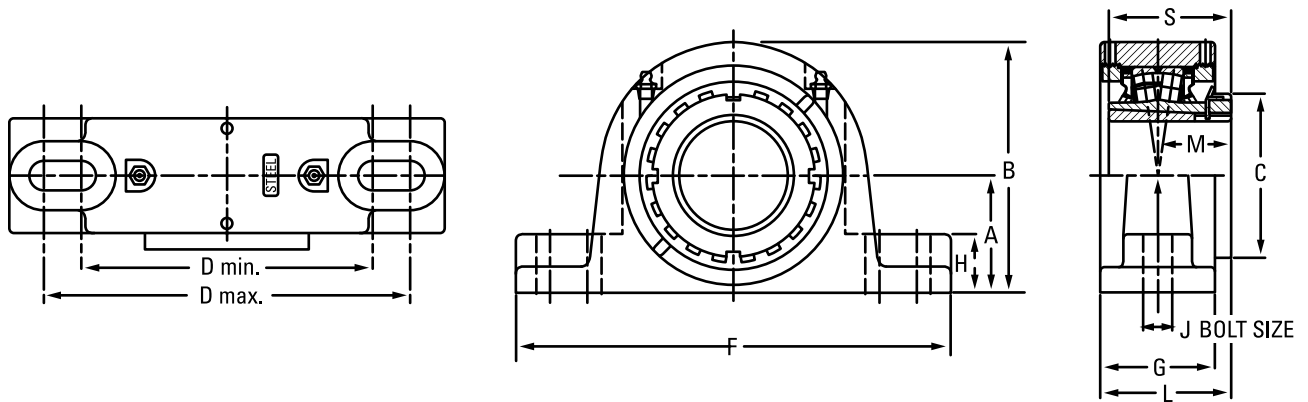

Bearing Part No.	Shaft Dia.	Bearing No.	A	B	C	D min.	D max.	F	G	H	J	L	M	S	Wt.
	mm in.		mm in.	mm in.	mm in.	mm in.	mm in.	mm in.	mm in.	mm in.	mm in.	mm in.	mm in.	mm in.	kg lbs.
TAPN09K107S	1 7/16 in.	22209	60.0	108.0	65.0	158.8	177.8	209.6	53.3	29.0	12	57.4	30.7	50.3	4.5
TAPN09K108S	1 1/2 in.		2.362	4.25	2.56	6.25	7.00	8.25	2.10	1.14	1/2	2.26	1.21	1.98	10
TAPN09K040S	40 mm														
TAPN10K111S	1 11/16 in.	22210	60.0	120.1	70.1	165.1	177.8	209.6	54.9	28.2	12	61.0	33.5	55.1	5.9
TAPN10K112S	1 3/4 in.		2.362	4.73	2.76	6.50	7.00	8.25	2.16	1.11	1/2	2.40	1.32	2.17	13
TAPN10K045S	45 mm														
TAPN11K115S	1 15/16 in.	22211	69.9	135.4	74.9	165.1	221.0	251.0	60.5	31.8	16	65.8	35.6	58.9	7.7
TAPN11K200S	2 in.		2.75	5.33	2.95	6.50	8.70	9.88	2.38	1.25	5/8	2.59	1.40	2.32	17
TAPN11K050S	50 mm														
TAPN12K055S	55 mm	22212	70.0	140.5	79.8	177.8	219.2	254.0	60.5	31.8	16	67.6	37.6	62.0	9.1
			2.756	5.53	3.14	7.00	8.63	10.00	2.38	1.25	5/8	2.66	1.48	2.44	20
TAPN13K203S	2 3/16 in.	22213	80.0	154.9	85.1	182.9	241.3	269.5	68.6	35.1	16	73.9	39.6	65.0	10.4
TAPN13K204S	2 1/4 in.		3.15	6.10	3.35	7.20	9.50	10.61	2.70	1.38	5/8	2.91	1.56	2.56	23
TAPN13K060S	60 mm														
TAPN15K207S	2 7/16 in.	22215	80.0	160.8	98.0	200.2	244.6	276.4	68.6	29.2	16	78.2	43.9	72.9	12.2
TAPN15K208S	2 1/2 in.		3.15	6.33	3.86	7.88	9.63	10.88	2.70	1.15	5/8	3.08	1.73	2.87	27
TAPN15K065S	65 mm														
TAPN16K211S	2 11/16 in.	22216	95.0	180.3	104.6	235.0	266.7	315.0	72.6	31.8	20	83.8	47.5	78.0	13.6
TAPN16K212S	2 3/4 in.		3.74	7.10	4.12	9.25	10.50	12.40	2.86	1.25	3/4	3.30	1.87	3.07	30
TAPN16K070S	70 mm														
TAPN17K215S	2 15/16 in.	22217	95.3	185.9	110.0	241.3	279.4	320.8	76.2	33.8	20	88.1	49.8	82.0	15.0
TAPN17K300S	3 in.		3.75	7.32	4.33	9.50	11.00	12.63	3.00	1.33	3/4	3.47	1.96	3.23	33
TAPN17K075S	75 mm														
TAPN18K080S	80 mm	22218	100.0	195.3	119.6	285.8	295.4	346.2	79.8	38.9	20	91.7	52.1	86.1	22.2
TAPN18K303S	3 3/16 in.		3.937	7.69	4.71	11.25	11.63	13.63	3.14	1.53	3/4	3.61	2.05	3.39	49
TAPN18K304S	3 1/4 in.														
TAPN19K085S	85 mm	22219	112.0	212.3	124.7	285.8	295.4	346.2	82.8	38.9	20	96.0	54.6	89.9	23.1
			4.409	8.36	4.91	11.25	11.63	13.63	3.26	1.53	3/4	3.78	2.15	3.54	51
TAPN20K307S	3 7/16 in.	22220	112.0	216.9	130.0	276.4	333.5	374.7	86.9	38.9	24	102.4	58.4	97.0	29.5
TAPN20K308S	3 1/2 in.		4.409	8.54	5.12	10.88	13.13	14.75	3.42	1.53	7/8	4.03	2.30	3.82	65
TAPN20K090S	90 mm														
TAPN22K315S	3 15/16 in.	22222	125.0	240.5	145.0	317.5	368.3	406.4	100.6	50.8	24	113.5	63.0	104.9	38.1
TAPN22K400S	4 in.		4.921	9.47	5.71	12.50	14.50	16.00	3.96	2.00	7/8	4.47	2.48	4.13	84
TAPN22K100S	100 mm														
TAPN24K403S	4 3/16 in.	22224	140.0	262.9	154.4	344.4	355.6	409.7	97.8	50.8	24	116.1	67.1	112.0	49.9
TAPN24K404S	4 1/4 in.		5.512	10.35	6.08	13.56	14.00	16.13	3.85	2.00	7/8	4.57	2.64	4.41	110
TAPN24K110S	110 mm														
TAPN26K407S	4 7/16 in.	22226	150.0	281.7	165.1	367.3	400.1	444.5	128.0	49.3	24	135.9	71.9	120.9	61.7
TAPN26K408S	4 1/2 in.		5.906	11.09	6.50	14.46	15.75	17.50	5.04	1.94	1	5.35	2.83	4.76	136
TAPN26K115S	115 mm														
TAPN28K415S	4 15/16 in.	22228	150.0	288.5	180.1	384.3	441.5	499.9	108.0	49.3	30	120.4	77.5	131.1	61.8
TAPN28K500S	5 in.		5.906	11.36	7.09	15.13	17.38	19.68	4.25	1.94	1 1/4	4.74	3.05	5.16	136
TAPN28K125S	125 mm														

TAPKT 9000 SERIES TWO-BOLT PILLOW BLOCKS

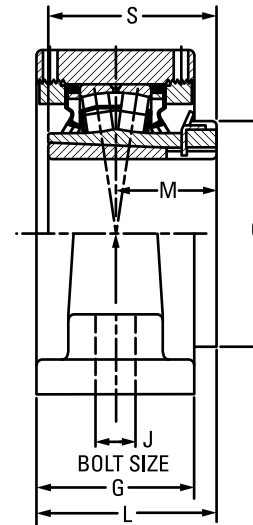
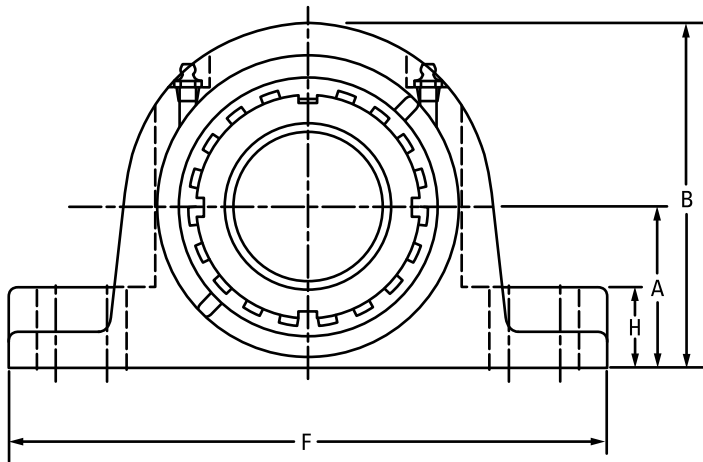
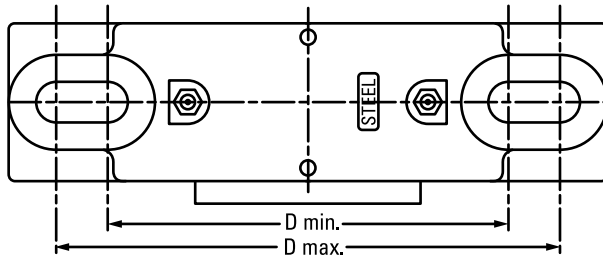

Bearing Part No.	Shaft Dia.	Bearing No.	A	B	C	D min.	D max.	F	G	H	J	L	M	S	Wt.
	mm in.		mm in.	mm in.	mm in.	mm in.	mm in.	mm in.	mm in.	mm in.	mm in.	mm in.	mm in.	mm in.	kg lbs.
TAPKT13K203S	2 3/16 in.	22213	76.2	153.7	85.1	194.6	223.0	285.8	73.7	35.1	20	76.5	36.6	65.0	10.0
TAPKT13K204S	2 1/4 in.		3.00	6.05	3.35	7.66	8.78	11.25	2.90	1.38	3/4	3.01	1.56	2.56	22
TAPKT13K060S	60 mm														
TAPKT15K207S	2 7/16 in.	22215	88.9	173.7	98.0	230.1	265.2	330.2	75.7	35.1	24	81.8	43.9	72.9	12.7
TAPKT15K208S	2 1/2 in.		3.50	6.84	3.86	9.06	10.44	13.00	2.98	1.38	7/8	3.22	1.73	2.87	28
TAPKT15K065S	65 mm														

DVPF FOUR-BOLT PILLOW BLOCKS

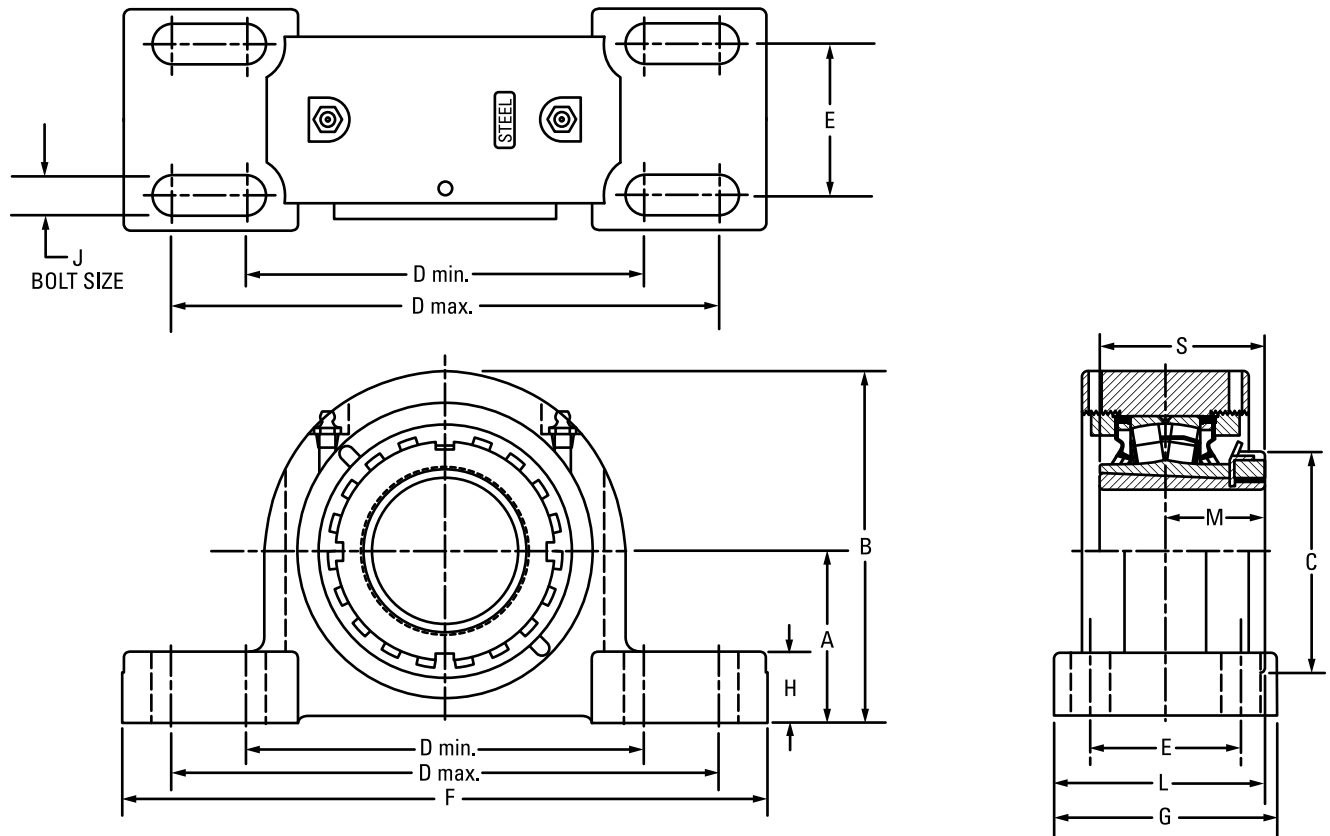

Bearing Part No.	Shaft Dia.	Bearing No.	A	B	C	D min.	D max.	E	F	G	H	J	L	M	S	Wt.
	mm in.		mm in.	mm in.	mm in.	mm in.	mm in.	mm in.	mm in.	mm in.	mm in.	mm in.	mm in.	mm in.	mm in.	kg lbs.
DVPF17K215S	2 15/16 in.	22217	82.6	172.5	110.0	193.0	231.1	47.8	265.2	79.5	32.8	16	86.6	49.8	82.0	23.1
DVPF17K300S	3 in.		3.25	6.79	4.33	7.60	9.10	1.88	10.44	3.13	1.29	5/8	3.41	1.96	3.23	51
DVPF17K075S	75 mm															
DVPF20K307S	3 7/16 in.	22220	95.3	200.2	130.0	225.6	276.4	50.8	312.4	95.3	39.6	20	101.3	58.4	97.0	31.8
DVPF20K308S	3 1/2 in.		3.75	7.88	5.12	8.88	10.88	2.00	12.30	3.75	1.56	3/4	3.99	2.30	3.82	70
DVPF20K090S	90 mm															
DVPF22K315S	3 15/16 in.	22222	108.0	223.0	145.0	276.4	339.9	57.2	378.0	109.5	35.6	20	110.7	63.0	104.9	38.6
DVPF22K400S	4 in.		4.25	8.78	5.71	10.88	13.38	2.25	14.88	4.31	1.40	3/4	4.36	2.48	4.13	85
DVPF22K100S	100 mm															
DVPF26K407S	4 7/16 in.	22226	120.7	250.7	165.1	302.3	368.3	63.5	409.7	120.7	40.1	20	123.7	71.9	120.1	62.1
DVPF26K408S	4 1/2 in.		4.75	9.87	6.50	11.90	14.50	2.50	16.13	4.75	1.58	3/4	4.87	2.83	4.73	137
DVPF26K115S	115 mm															

TAPK 9000 SERIES FOUR-BOLT PILLOW BLOCKS

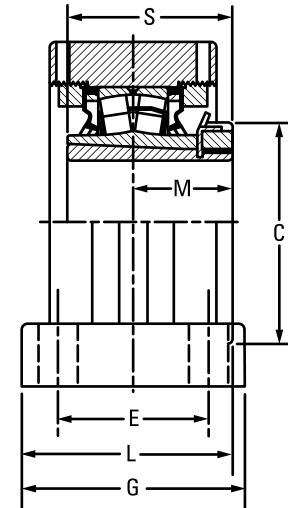
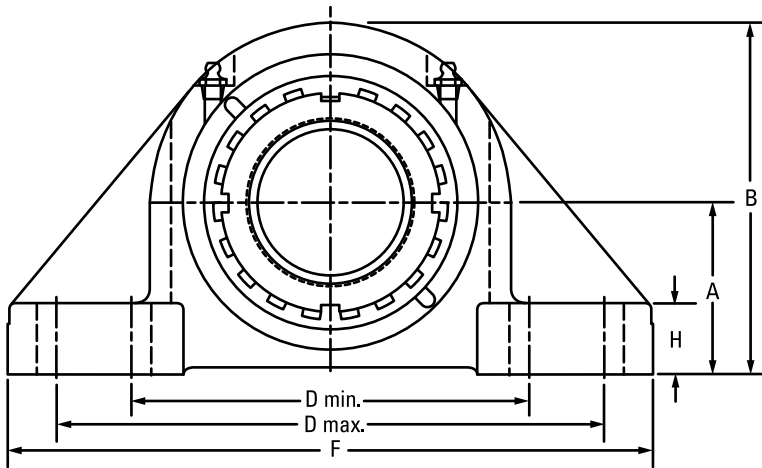
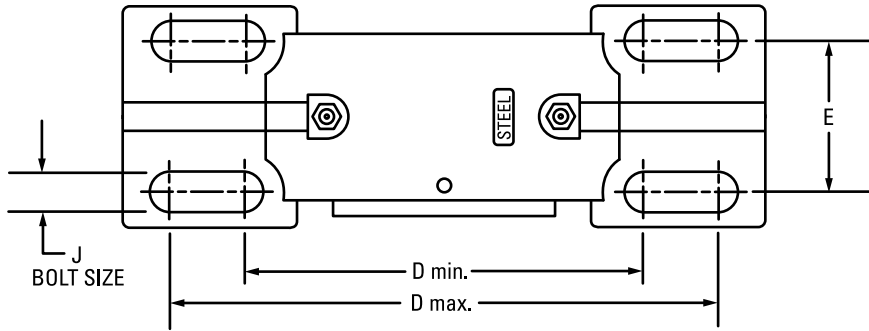

Bearing Part No.	Shaft Dia.	Bearing No.	A	B	C	D min.	D max.	E	F	G	H	J	L	M	S	Wt.
	mm in.		mm in.	mm in.	mm in.	mm in.	mm in.	mm in.	mm in.	mm in.	mm in.	mm in.	mm in.	mm in.	mm in.	kg lbs.
TAPK15K207S	2 7/16 in.	22215	88.9	173.5	98.0	230.1	265.2	69.9	330.2	108.0	39.1	20	98.0	43.9	72.9	13.2
TAPK15K208S	2 1/2 in.		3.50	6.83	3.86	9.06	10.44	2.75	13.00	4.25	1.54	3/4	3.86	1.73	2.87	29
TAPK15K065S	65 mm															
TAPK17K215S	2 15/16 in.	22217	101.6	201.2	110.0	274.6	309.6	76.2	381.0	120.7	38.1	20	110.2	49.8	82.0	16.8
TAPK17K300S	3 in.		4.00	7.92	4.33	10.81	12.19	3.00	15.00	4.75	1.50	3/4	4.34	1.96	3.23	37
TAPK17K075S	75 mm															
TAPK20K307S	3 7/16 in.	22220	127.0	239.8	130.0	317.5	355.6	88.9	425.5	139.7	41.4	22	128.3	58.4	97.0	31.8
TAPK20K308S	3 1/2 in.		5.00	9.44	5.12	12.50	14.00	3.50	16.75	5.50	1.63	7/8	5.05	2.30	3.82	70
TAPK20K090S	90 mm															
TAPK22K315S	3 15/16 in.	22222	146.1	273.8	145.0	354.1	395.2	101.6	469.9	158.8	45.7	24	138.2	63.0	104.9	39.5
TAPK22K400S	4 in.		5.75	10.78	5.71	13.94	15.56	4.00	18.50	6.25	1.80	1	5.44	2.48	4.13	87
TAPK22K100S	100 mm															
TAPK26K407S	4 7/16 in.	22226	155.6	283.2	165.1	387.4	425.5	108.0	514.4	171.5	50.8	24	157.5	71.9	120.9	61.7
TAPK26K408S	4 1/2 in.		6.125	11.15	6.50	15.25	16.75	4.25	20.25	6.75	2.00	1 1/8	6.20	2.83	4.76	136
TAPK26K115S	115 mm															

TAPH SAF-STYLE FOUR-BOLT PILLOW BLOCKS

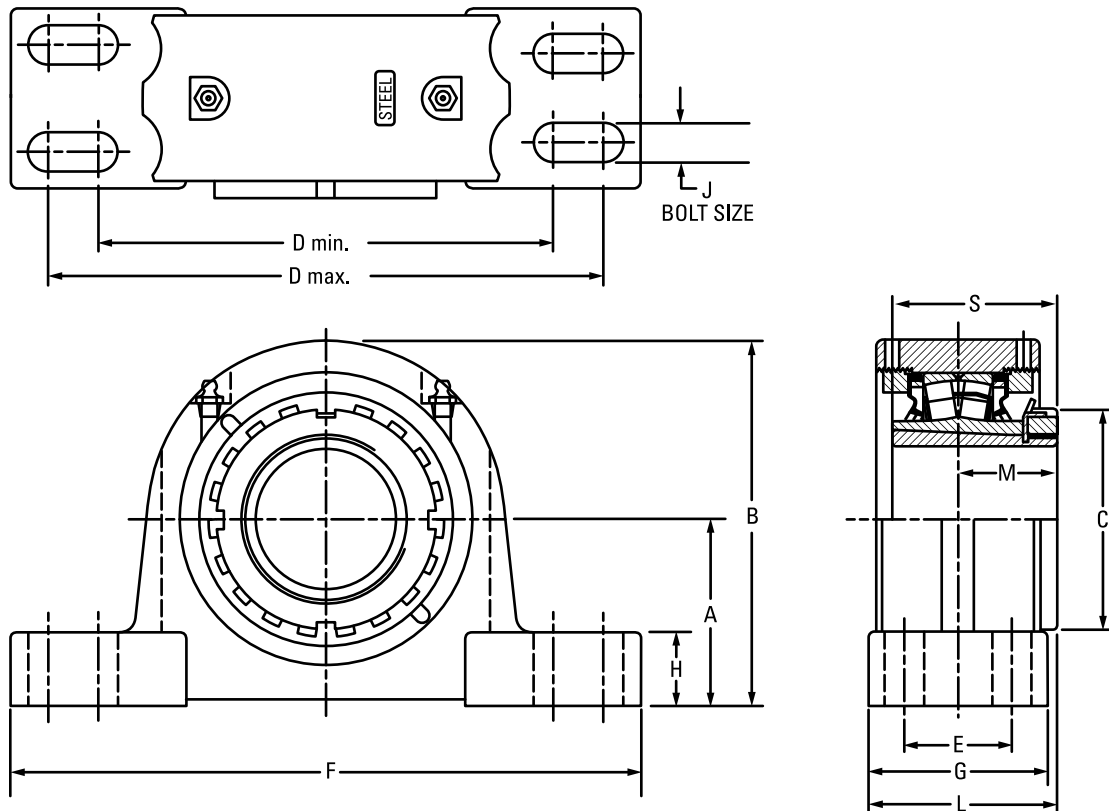

Bearing Part No.	Shaft Dia.	Bearing No.	A	B	C	D min.	D max.	E	F	G	H	J	L	M	S	Wt.
	mm in.		mm in.	mm in.	mm in.	mm in.	mm in.	mm in.	mm in.	mm in.	mm in.	mm in.	mm in.	mm in.	mm in.	kg lbs.
TAPH11K115S	1 15/16 in.	22211	69.9	134.9	74.9	182.4	217.4	39.9	251.0	68.6	31.8	16	69.9	35.6	58.9	8.6
TAPH11K200S	2 in.		2.75	5.31	2.95	7.18	8.56	1.57	9.88	2.70	1.25	5/8	2.75	1.40	2.32	19
TAPH11K050S	50 mm															
TAPH13K203S	2 3/16 in.	22213	76.2	151.1	85.1	182.4	217.4	50.8	261.9	82.6	31.2	12	81.0	39.6	65.0	11.3
TAPH13K204S	2 1/4 in.		3.00	5.95	3.35	7.18	8.56	2.00	10.31	3.25	1.23	1/2	3.19	1.56	2.56	25
TAPH13K060S	60 mm															
TAPH15K207S	2 7/16 in.	22215	82.6	162.1	98.0	201.7	246.1	47.8	276.4	79.5	32.8	12	83.6	43.9	72.9	13.2
TAPH15K208S	2 1/2 in.		3.25	6.38	3.86	7.94	9.69	1.88	10.88	3.13	1.29	1/2	3.29	1.73	2.87	29
TAPH15K065S	65 mm															
TAPH17K215S	2 15/16 in.	22217	95.3	182.9	110.0	239.8	287.3	54.1	320.8	92.2	32.0	16	96.0	49.8	82.0	16.8
TAPH17K300S	3 in.		3.75	7.20	4.33	9.44	11.31	2.13	12.63	3.63	1.26	5/8	3.78	1.96	3.23	37
TAPH17K075S	75 mm															
TAPH20K307S	3 7/16 in.	22220	114.3	216.9	130.0	276.4	339.9	60.5	381	109.5	41.9	20	113.3	58.4	97.0	31.8
TAPH20K308S	3 1/2 in.		4.50	8.54	5.12	10.88	13.38	2.38	15.00	4.31	1.65	3/4	4.46	2.30	3.82	70
TAPH20K090S	90 mm															
TAPH22K315S	3 15/16 in.	22222	125.5	238.3	145.0	301.8	368.3	69.9	406.4	120.7	45.0	20	123.4	63.0	104.9	39.5
TAPH22K400S	4 in.		4.94	9.38	5.71	11.88	14.50	2.75	16.00	4.75	1.77	3/4	4.86	2.48	4.13	87
TAPH22K100S	100 mm															
TAPH26K407S	4 7/16 in.	22226	152.4	284.0	165.1	362.0	400.1	82.6	444.5	128.0	51.8	22	135.9	71.9	120.9	61.7
TAPH26K408S	4 1/2 in.		6.00	11.18	6.50	14.25	15.75	3.25	17.50	5.04	2.04	7/8	5.35	2.83	4.76	136
TAPH26K115S	115 mm															
TAPH28K415S	4 15/16 in.	22228	152.4	290.8	180.1	406.4	435.1	85.9	500.4	128.0	51.8	24	141.5	77.5	131.1	61.8
TAPH28K500S	5 in.		6.00	11.45	7.09	16.00	17.13	3.38	19.70	5.04	2.04	1	5.57	3.05	5.16	136
TAPH28K125S	125 mm															

TAPG SN-STYLE FOUR-BOLT PILLOW BLOCKS

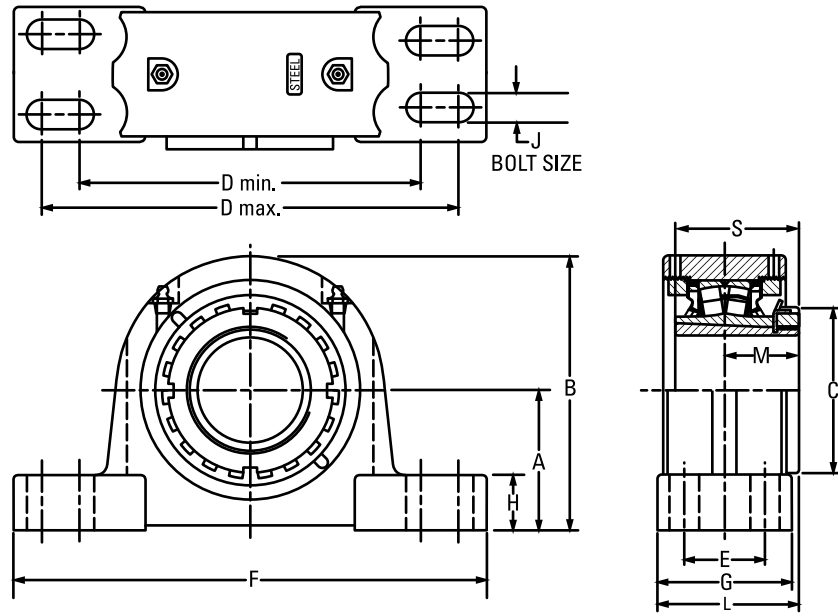

Bearing Part No.	Shaft Dia.	Bearing No.	A	B	C	D min.	D max.	E	F	G	H	J	L	M	S	Wt.
	mm in.		mm in.	mm in.	mm in.	mm in.	mm in.	mm in.	mm in.	mm in.	mm in.	mm in.	mm in.	mm in.	mm in.	kg lbs.
TAPG11K115S	1 15/16 in.	22211	69.9	134.9	74.9	182.4	217.4	39.9	251.0	68.6	31.8	16	69.9	35.6	58.9	8.6
TAPG11K200S	2 in.		2.75	5.31	2.95	7.18	8.56	1.57	9.88	2.70	1.25	5/8	2.75	1.40	2.32	19
TAPG11K050S	50 mm															
TAPG12K055S	55 mm	22212	70.0	140.5	79.8	177.8	219.2	35.1	254.0	69.9	31.8	12	72.6	37.6	62.0	9.9
			2.756	5.53	3.14	7.00	8.63	1.38	10.00	2.75	1.25	1/2	2.86	1.48	2.44	22
TAPG13K203S	2 3/16 in.	22213	80.0	154.9	85.1	182.4	217.4	48.0	261.9	82.6	35.1	16	81.0	39.6	65.0	11.3
TAPG13K204S	2 1/4 in.		3.15	6.10	3.35	7.18	8.56	1.89	10.31	3.25	1.38	5/8	3.19	1.56	2.56	25
TAPG13K060S	60 mm															
TAPG15K207S	2 7/16 in.	22215	80.0	162.1	98.0	201.7	246.1	39.6	276.4	79.5	30.2	16	83.8	43.9	72.9	13.2
TAPG15K208S	2 1/2 in.		3.15	6.38	3.86	7.94	9.69	1.56	10.88	3.13	1.19	5/8	3.30	1.73	2.87	29
TAPG15K065S	65 mm															
TAPG16K211S	2 11/16 in.	22216	95.0	180.3	104.6	235.0	266.7	50.0	315.0	89.9	31.8	16	92.5	47.5	78.0	14.9
TAPG16K212S	2 3/4 in.		3.74	7.10	4.12	9.25	10.50	1.97	12.40	3.54	1.25	5/8	3.64	1.87	3.07	33
TAPG16K070S	70 mm															
TAPG17K215S	2 15/16 in.	22217	95.0	182.9	110.0	239.8	287.3	52.3	320.8	92.2	31.8	20	96.0	49.8	82.0	16.8
TAPG17K300S	3 in.		3.74	7.20	4.33	9.44	11.31	2.06	12.63	3.63	1.25	3/4	3.78	1.96	3.23	37
TAPG17K075S	75 mm															
TAPG18K080S	80 mm	22218	100.0	195.3	119.6	282.7	298.5	50.0	344.9	100.1	39.6	16	102.1	52.1	86.1	24.5
TAPG18K303S	3 3/16 in.		3.937	7.69	4.71	11.13	11.75	1.97	13.58	3.94	1.56	5/8	4.02	2.05	3.39	54
TAPG18K304S	3 1/4 in.															
TAPG19K085S	85 mm	22219	112.0	212.3	124.7	282.7	298.5	50.0	344.9	100.1	39.6	16	104.6	54.6	89.9	25.4
			4.409	8.36	4.91	11.13	11.75	1.97	13.58	3.94	1.56	5/8	4.12	2.15	3.54	56
TAPG20K307S	3 7/16 in.	22220	112.0	214.6	130.0	276.4	339.9	60.5	381.0	109.5	39.6	20	113.3	58.4	97.0	31.8
TAPG20K308S	3 1/2 in.		4.409	8.45	5.12	10.88	13.38	2.38	15.00	4.31	1.56	3/4	4.46	2.30	3.82	70
TAPG20K090S	90 mm															
TAPG22K315S	3 15/16 in.	22222	125.0	238.3	145.0	301.8	368.3	69.9	406.4	120.7	44.5	20	123.4	63.0	104.9	39.5
TAPG22K400S	4 in.		4.921	9.38	5.71	11.88	14.50	2.75	16.00	4.75	1.75	3/4	4.86	2.48	4.13	87
TAPG22K100S	100 mm															
TAPG24K403S	4 3/16 in.	22224	140.0	262.9	154.4	342.9	355.6	70.1	410.0	120.7	50.8	16	127.5	67.1	112.0	49.9
TAPG24K404S	4 1/4 in.		5.512	10.35	6.08	13.50	14.00	2.76	16.14	4.75	2.00	5/8	5.02	2.64	4.41	110
TAPG24K110S	110 mm															
TAPG26K407S	4 7/16 in.	22226	150.0	281.7	165.1	367.28	400.1	81.0	444.5	128.0	49.3	24	135.9	71.88	120.9	61.7
TAPG26K408S	4 1/2 in.		5.906	11.09	6.50	14.46	15.75	3.19	17.50	5.04	1.94	1	5.35	2.83	4.76	136
TAPG26K115S	115 mm															
TAPG28K415S	4 15/16 in.	22228	150.0	288.4	180.1	384.3	447.8	80.0	500.4	128.0	49.3	24	141.5	77.5	131.1	61.8
TAPG28K500S	5 in.		5.906	11.36	7.09	15.13	17.63	3.15	19.70	5.04	1.94	1	5.57	3.05	5.16	136
TAPG28K125S	125 mm															

DVC PILOTED FLANGE CARTRIDGES

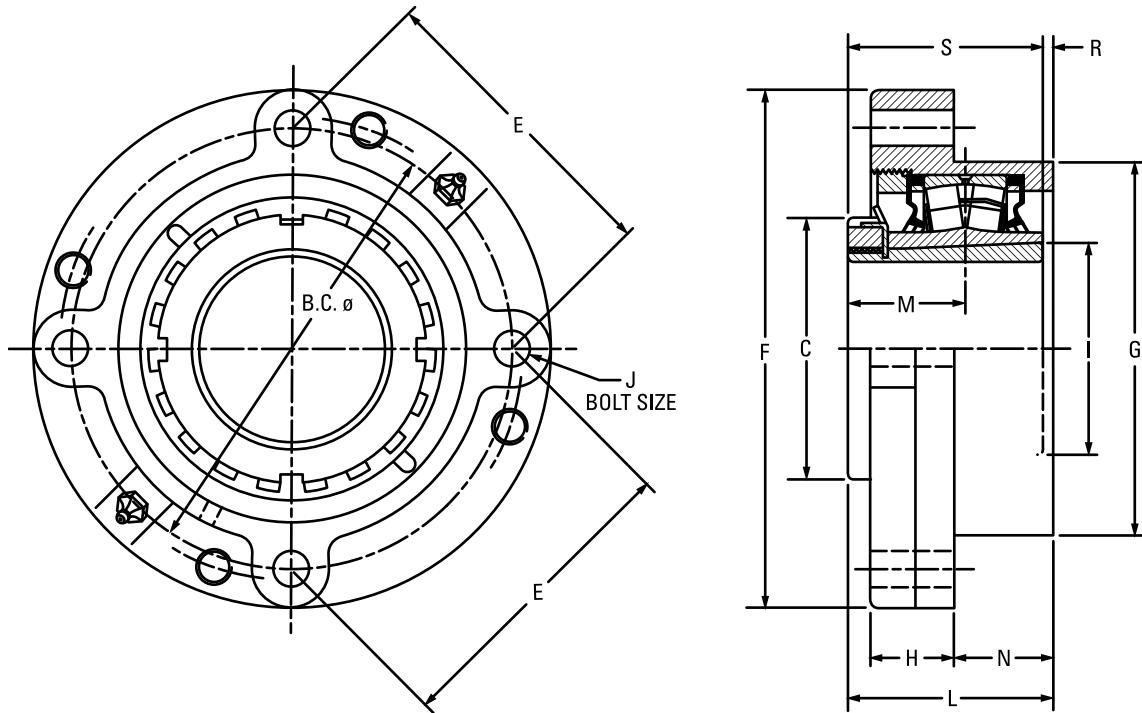

Bearing Part No.	Shaft Dia.	Bearing No.	B.C.	C	E	F	G ⁽¹⁾	H	I	J	L	M	N	R	S	Wt.
	mm in.		mm in.	mm in.	mm in.	mm in.	mm in.	mm in.	mm in.	mm in.	mm in.	mm in.	mm in.	mm in.	mm in.	kg lbs.
DVC09K107S	1 7/16 in.	22209	111.3	65.0	78.5	133.4	92.1	26.7	48.3	10	55.4	30.7	23.9	5.1	50.3	4.1
DVC09K108S	1 1/2 in.		4.38	2.56	3.09	5.25	3.625	1.05	1.90	7/16	2.18	1.21	0.94	0.20	1.98	9
DVC09K040S	40 mm															
DVC10K111S	1 11/16 in.	22210	130.3	70.1	91.9	155.7	107.95	26.7	58.9	10	60.1	33.5	25.4	5.1	55.1	4.5
DVC10K112S	1 3/4 in.		5.13	2.76	3.62	6.13	4.250	1.05	2.32	7/16	2.37	1.32	1.00	0.20	2.17	10
DVC10K045S	45 mm															
DVC11K115S	1 15/16 in.	22211	136.7	74.9	96.5	162.1	114.3	31.5	62.2	10	63.2	35.6	25.4	4.1	58.9	5.0
DVC11K200S	2 in.		5.38	2.95	3.80	6.38	4.500	1.24	2.45	7/16	2.49	1.40	1.00	0.16	2.32	11
DVC11K050S	50 mm															
DVC13K203S	2 3/16 in.	22213	152.4	82.6	107.7	181.1	127.0	37.3	84.8	12	65.5	39.6	25.4	-2.8	65.0	7.3
DVC13K204S	2 1/4 in.		6.00	3.35	4.24	7.13	5.000	1.47	3.34	1/2	2.58	1.56	1.00	-0.11	2.56	16
DVC13K060S	60 mm															
DVC15K207S	2 7/16 in.	22215	165.1	98.0	116.8	193.8	139.7	32.3	79.0	12	69.9	43.9	31.8	3.6	72.9	8.2
DVC15K208S	2 1/2 in.		6.50	3.86	4.60	7.63	5.500	1.27	3.11	1/2	2.75	1.73	1.25	0.14	2.87	18
DVC15K065S	65 mm															
DVC17K215S	2 15/16 in.	22217	190.5	110.0	134.6	222.3	161.9	32.5	90.2	16	79.8	49.8	35.1	2.3	82.0	11.3
DVC17K300S	3 in.		7.50	4.33	5.30	8.75	6.375	1.28	3.55	5/8	3.14	1.96	1.38	0.09	3.23	25
DVC17K075S	75 mm															
DVC20K307S	3 7/16 in.	22220	219.2	130.0	154.9	260.4	187.3	41.1	106.2	20	91.9	58.4	35.1	5.1	97.0	16.8
DVC20K308S	3 1/2 in.		8.63	5.12	6.10	10.25	7.375	1.62	4.18	3/4	3.62	2.30	1.38	0.20	3.82	37
DVC20K090S	90 mm															
DVC22K315S	3 15/16 in.	22222	238.3	145.0	168.4	276.4	206.4	48.0	116.8	20	100.1	63.0	38.1	4.6	104.9	26.3
DVC22K400S	4 in.		9.38	5.71	6.63	10.88	8.125	1.89	4.60	3/4	3.94	2.48	1.50	0.18	4.13	58
DVC22K100S	100 mm															
DVC26K407S ⁽²⁾	4 7/16 in.	22226	298.5	165.1	149.4	342.9	260.4	47.0	137.9	20	116.8	71.9	48.3	4.1	120.9	34.5
DVC26K408S ⁽²⁾	4 1/2 in.		11.75 ⁽²⁾	6.50	5.88 ⁽²⁾	13.50	10.250	1.85	5.43	3/4 ⁽²⁾	4.60	2.83	1.90	0.16	4.76	76
DVC26K115S ⁽²⁾	115 mm															

⁽¹⁾Pilot tolerance: +0/-0.05 mm (+0/-0.002 in.).

⁽²⁾Six-bolt housing.

TAFC SQUARE PILOTED FLANGE CARTRIDGES

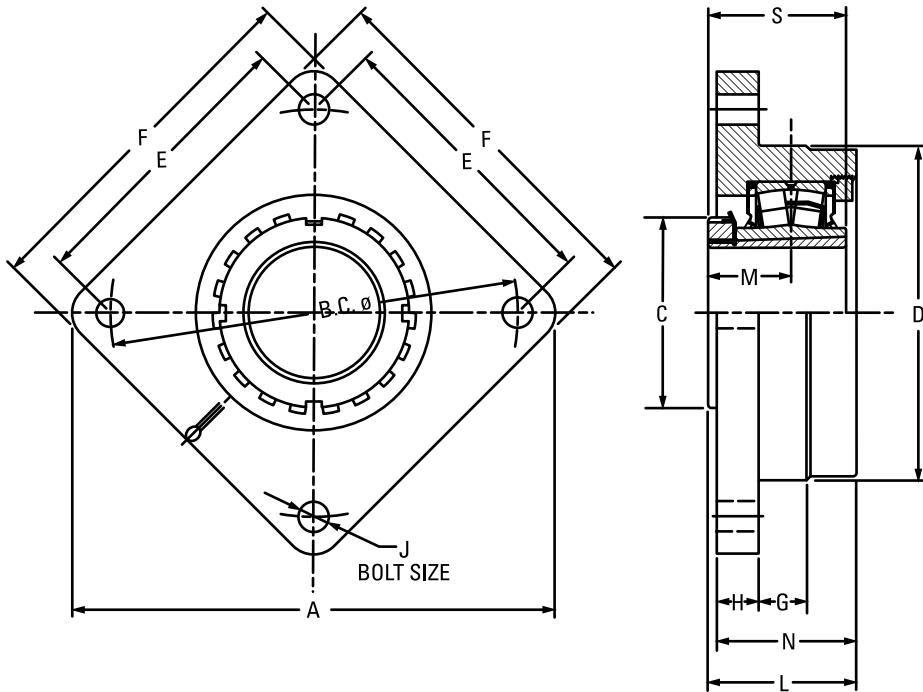

Bearing Part No.	Shaft Dia.	Bearing No.	A	B.C.	C	D ⁽¹⁾	E	F	G	H	J	L	M	N	S	Wt.
	mm in.		mm in.	mm in.	mm in.	mm in.	mm in.	mm in.	mm in.	mm in.	mm in.	mm in.	mm in.	mm in.	mm in.	kg lbs.
TAFC15K207S	2 7/16 in.	22215	255.0	215.1	98.0	169.9	152.4	192.0	25.4	23.9	16	79.5	43.9	64.8	72.9	11.3
TAFC15K208S	2 1/2 in.		10.04	8.47	3.86	6.690	6.00	7.56	1.00	0.94	5/8	3.13	1.73	2.55	2.87	25
TAFC15K065S	65 mm															
TAFC17K215S	2 15/16 in.	22217	282.4	240.0	110.0	190.0	169.7	212.1	25.4	25.4	16	88.6	49.8	69.9	82.0	13.6
TAFC17K300S	3 in.		11.12	9.45	4.33	7.480	6.68	8.35	1.00	1.00	5/8	3.49	1.96	2.75	3.23	30
TAFC17K075S	75 mm															
TAFC20K307S	3 7/16 in.	22220	330.2	279.9	130.0	230.1	197.9	247.9	31.8	28.7	20	105.7	58.4	94.2	97.0	18.1
TAFC20K308S	3 1/2 in.		13.00	11.02	5.12	9.060	7.79	9.76	1.25	1.13	3/4	4.16	2.30	3.71	3.82	40
TAFC20K090S	90 mm															
TAFC22K315S	3 15/16 in.	22222	367.0	309.9	145.0	255.0	219.2	274.3	44.5	26.4	20	113.0	63.0	101.1	104.9	27.2
TAFC22K400S	4 in.		14.45	12.20	5.71	10.039	8.63	10.80	1.75	1.04	3/4	4.45	2.48	3.98	4.13	60
TAFC22K100S	100 mm															
TAFC26K407S	4 7/16 in.	22226	411.5	355.1	165.1	290.0	251.0	298.5	41.9	32.0	24	130.6	71.9	114.3	120.9	42.6
TAFC26K408S	4 1/2 in.		16.20	13.98	6.50	11.417	9.88	11.75	1.65	1.26	7/8	5.14	2.83	4.50	4.76	94
TAFC26K115S	115 mm															

⁽¹⁾Pilot tolerance: +0/-0.05 mm (+0/-0.002 in.).

TAFB SQUARE FLANGE BLOCKS

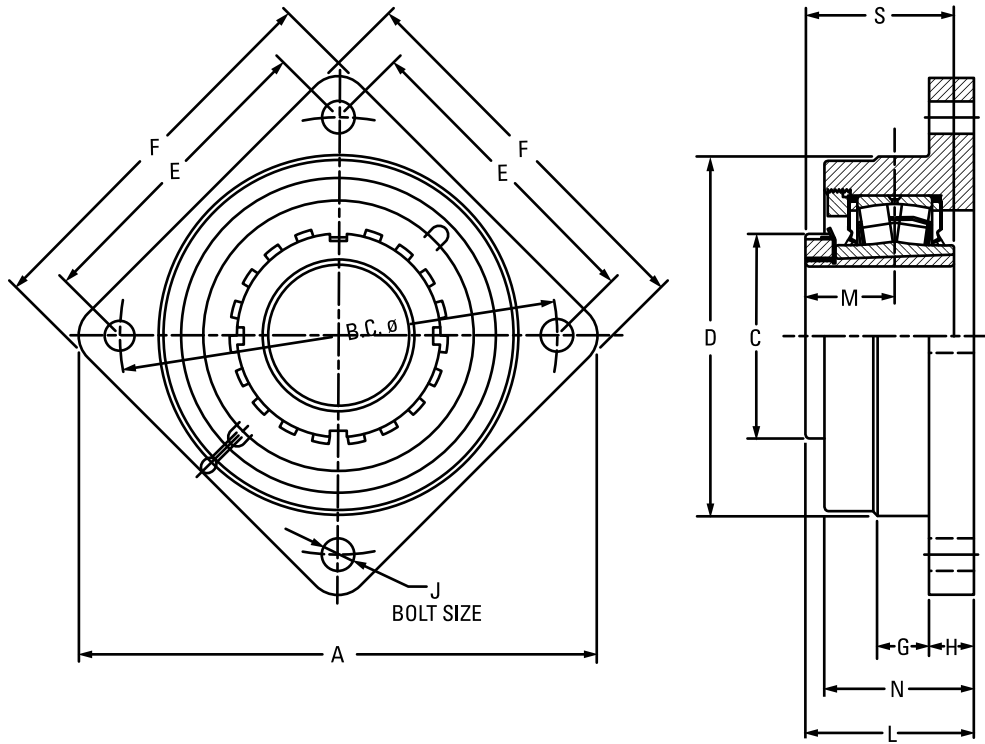

Bearing Part No.	Shaft Dia.	Bearing No.	A	B.C. Ø	C	D	E	F	G	H	J	L	M	N	S	Wt.
	mm in.		mm in.	mm in.	mm in.	mm in.	mm in.	mm in.	mm in.	mm in.	mm in.	mm in.	mm in.	mm in.	mm in.	kg lbs.
TAFB15K207S	2 7/16 in.	22215	255.0	215.1	98.0	169.9	152.4	192.0	25.4	23.9	16	73.7	43.9	64.8	72.9	11.3
TAFB15K208S	2 1/2 in.		10.04	8.47	3.86	6.69	6.00	7.56	1.00	0.94	5/8	2.90	1.73	2.55	2.87	25
TAFB15K065S	65 mm															
TAFB17K215S	2 15/16 in.	22217	282.4	240.0	110.0	190.0	169.7	212.1	25.4	25.4	16	88.6	49.8	69.9	82.0	13.6
TAFB17K300S	3 in.		11.12	9.45	4.33	7.48	6.68	8.35	1.00	1.00	5/8	3.49	1.96	2.75	3.23	30
TAFB17K075S	75 mm															
TAFB20K307S	3 7/16 in.	22220	330.2	280.0	130.0	230.1	197.9	247.9	31.8	28.7	20	105.7	58.4	94.2	97.0	18.1
TAFB20K308S	3 1/2 in.		13.00	11.02	5.12	9.06	7.79	9.76	1.25	1.13	3/4	4.16	2.30	3.71	3.82	40
TAFB20K090S	90 mm															
TAFB22K315S	3 15/16 in.	22222	367.0	309.9	145.0	255.0	219.2	279.4	44.5	26.4	20	113.0	63.0	101.1	104.9	27.2
TAFB22K400S	4 in.		14.45	12.20	5.71	10.04	8.63	11.00	1.75	1.04	3/4	4.45	2.48	3.98	4.13	60
TAFB22K100S	100 mm															
TAFB26K407S	4 7/16 in.	22226	411.5	354.8	165.1	290.0	251.0	298.5	41.9	32.0	24	130.6	71.9	114.3	120.9	42.6
TAFB26K408S	4 1/2 in.		16.20	13.97	6.50	11.42	9.88	11.75	1.65	1.26	7/8	5.14	2.83	4.50	4.76	94
TAFB26K115S	115 mm															

DVF SQUARE FLANGE BLOCKS

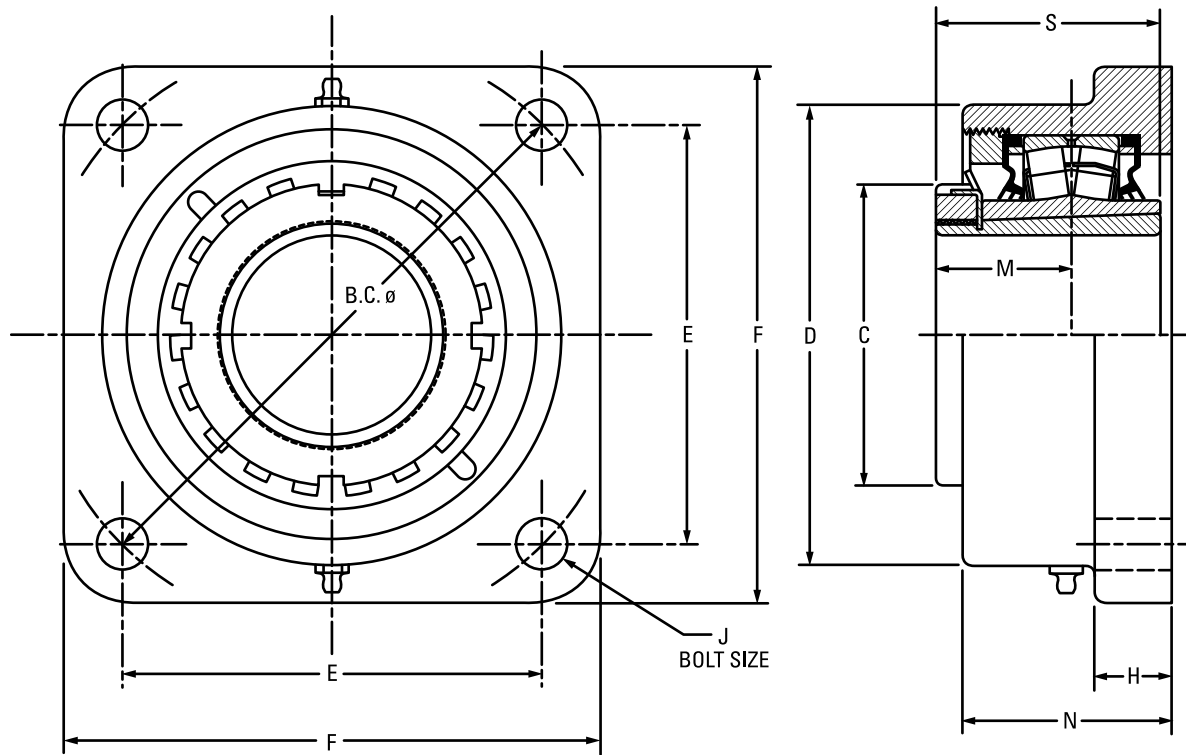

Bearing Part No.	Shaft Dia.	Bearing No.	B.C.	C	D	E	F	H	J	M	N	S	Wt.
	mm in.		mm in.	mm in.	mm in.	mm in.	mm in.	mm in.	mm in.	mm in.	mm in.	mm in.	kg lbs.
DVF09K107S	1 7/16 in.	22209	125.7 4.95	65.0 2.56	101.6 4.00	88.9 3.50	117.6 4.63	19.1 0.75	12 1/2	30.7 1.21	56.1 2.21	50.3 1.98	5.0 11
DVF09K108S	1 1/2 in.	22209	148.3	65.0	107.8	104.9	136.7	19.1	12	30.7	56.1	50.3	5.0
DVF09K040S	40 mm		5.84	2.56	4.25	4.13	5.38	0.75	1/2	1.21	2.21	1.98	11
DVF10K111S	1 11/16 in.	22210	148.3 5.84	70.1 2.76	118.4 4.66	104.9 4.13	136.7 5.38	22.4 0.88	12 1/2	33.5 1.32	52.3 2.06	55.1 2.17	5.5 12
DVF10K112S	1 3/4 in.	22210	157.2	70.1	118.4	111.3	143.0	22.4	12	33.5	52.3	55.1	5.5
DVF10K045S	45 mm		6.19	2.76	4.66	4.38	5.63	0.88	1/2	1.32	2.06	2.17	12
DVF11K115S	1 19/16 in.	22211	157.2	74.9	121.9	111.3	139.7	22.4	12	35.6	65.0	58.9	5.44
DVF11K200S	2 in.		6.19	2.95	4.80	4.38	5.50	0.88	1/2	1.40	2.56	2.32	12
DVF11K050S	50 mm												
DVF13K203S	2 3/16 in.	22213	175.0	85.1	137.9	124.0	157.2	25.4	16	39.6	66.8	65.0	6.8
DVF13K204S	2 1/4 in.		6.89	3.35	5.43	4.88	6.19	1.00	5/8	1.56	2.63	2.56	15
DVF13K060S	60 mm												
DVF15K207S	2 7/16 in.	22215	193.0	98.0	146.0	136.7	168.4	25.4	16	43.9	72.4	72.9	8.2
DVF15K208S	2 1/2 in.		7.60	3.86	5.75	5.38	6.63	1.00	5/8	1.73	2.85	2.87	18
DVF15K065S	65 mm												
DVF17K215S	2 15/16 in.	22217	215.4	110.0	170.7	152.4	189.0	26.9	20	49.8	77.0	82.0	12.7
DVF17K300S	3 in.		8.48	4.33	6.72	6.00	7.44	1.06	3/4	1.96	3.03	3.23	28
DVF17K075S	75 mm												
DVF20K307S	3 7/16 in.	22220	251.5	130.0	193.8	177.8	219.2	33.3	20	58.4	84.1	97.0	17.7
DVF20K308S	3 1/2 in.		9.90	5.12	7.63	7.00	8.63	1.31	3/4	2.30	3.31	3.82	39
DVF20K090S	90 mm												
DVF22K315S	3 15/16 in.	22222	278.4	145.0	215.9	196.9	253.2	38.1	24	63.0	103.1	104.9	24.0
DVF22K400S	4 in.		10.96	5.71	8.50	7.75	9.97	1.50	7/8	2.48	4.06	4.13	53
DVF22K100S	100 mm												
DVF26K407S	4 7/16 in.	22226	314.5	165.1	263.7	222.3	276.4	38.1	24	71.9	106.9	120.9	34.0
DVF26K408S	4 1/2 in.		12.38	6.50	10.38	8.75	10.88	1.50	7/8	2.83	4.21	4.76	75
DVF26K115S	115 mm												

TAFK 9000 SERIES SQUARE FLANGE BLOCKS

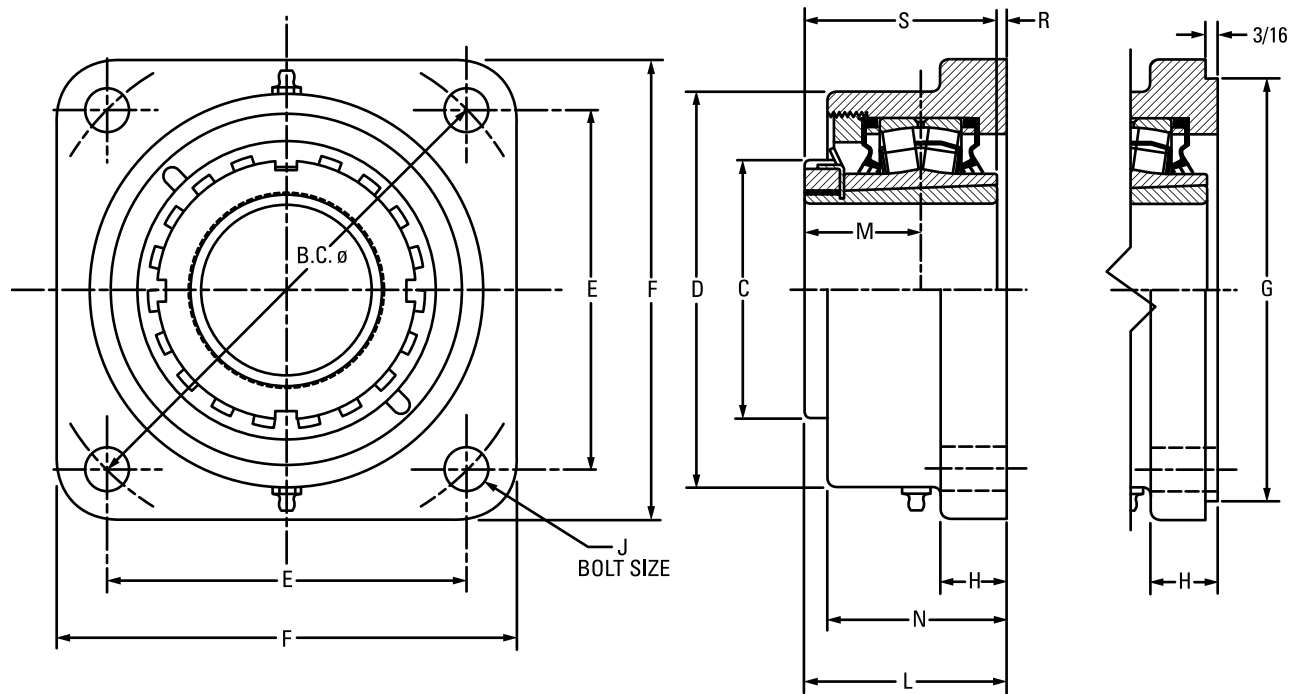

Bearing Part No.	Shaft Dia.	Bearing No.	B.C.	C	D	E	F	G ⁽¹⁾⁽²⁾⁽³⁾	H	J	L _{FIX}	L _{EXP}	M	N	R	S	Wt.
	mm in.		mm in.	mm in.	mm in.	mm in.	mm in.	mm in.	mm in.	mm in.	mm in.	mm in.	mm in.	mm in.	mm in.	mm in.	kg lbs.
TAFK11K115S	1 15/16 in.	22211	161.5	74.9	130.3	114.3	149.4	127.00	25.4	16	71.6	72.9	35.6	66.8	12.7	58.9	5.0
TAFK11K200S	2 in.		6.36	2.95	5.13	4.50	5.88	5.000	1.00	5/8	2.82	2.87	1.40	2.63	0.50	2.32	11
TAFK11K050S	50 mm																
TAFK13K203S	2 3/16 in.	22213	180.8	85.1	146.1	127.8	157.2	138.13	25.4	16	77.7	79.8	39.6	72.4	12.7	65.0	6.4
TAFK13K204S	2 1/4 in.		7.12	3.35	5.75	5.03	6.19	5.438	1.00	5/8	3.06	3.14	1.56	2.85	0.50	2.56	14
TAFK13K060S	60 mm																
TAFK15K207S	2 7/16 in.	22215	215.9	98.0	168.9	152.7	189.0	160.35	26.9	20	84.8	86.9	43.9	76.2	11.9	72.9	7.7
TAFK15K208S	2 1/2 in.		8.50	3.86	6.65	6.01	7.44	6.313	1.06	3/4	3.34	3.42	1.73	3.00	0.47	2.87	17
TAFK15K065S	65 mm																
TAFK17K215S	2 15/16 in.	22217	41.3	110.0	193.8	170.7	212.9	187.33	33.3	20	96.3	98.3	49.8	84.1	14.2	82.0	10.4
TAFK17K300S	3 in.		9.50	4.33	7.63	6.72	8.38	7.375	1.31	3/4	3.79	3.87	1.96	3.31	0.56	3.23	23
TAFK17K075S	75 mm																
TAFK20K307S	3 7/16 in.	22220	298.5	130.0	215.9	211.1	268.2	225.43	38.1	24	114.6	116.6	58.4	103.1	17.5	97.0	15.9
TAFK20K308S	3 1/2 in.		11.75	5.12	8.50	8.31	10.56	8.875	1.50	7/8	4.51	4.59	2.30	4.06	0.69	3.82	35
TAFK20K090S	90 mm																
TAFK22K315S ⁽⁴⁾	3 15/16 in.	22222	327.2	145.0	256.5	163.6	384.3	263.53	38.1	24	117.3	119.4	63.0	106.9	12.4	104.9	24.9
TAFK22K400S ⁽⁴⁾	4 in.		12.88 ⁽⁴⁾	5.71	10.10	6.44 ⁽⁴⁾	15.13	10.375	1.50	1 ⁽⁴⁾	4.62	4.70	2.48	4.21	0.49	4.13	55
TAFK22K100S ⁽⁴⁾	100 mm																
TAFK26K407S ⁽⁴⁾	4 7/16 in.	22226	355.6	165.1	284.2	177.8	419.1	284.18	38.1	27	147.3	149.4	71.9	135.1	26.4	120.9	49.0
TAFK26K408S ⁽⁴⁾	4 1/2 in.		14.00 ⁽⁴⁾	6.50	11.19	7.00 ⁽⁴⁾	16.50	11.188	1.50	1 1/8 ⁽⁴⁾	5.80	5.88	2.83	5.32	1.04	4.76	108
TAFK26K115S ⁽⁴⁾	115 mm																

⁽¹⁾Pilot tolerance: +0/-0.05 mm (+0/-0.002 in.).

⁽²⁾Add (p) to the end of the housing designation in the part number to order with pilot using G dimension.

⁽³⁾Piloted flange blocks will be quoted (price and delivery) upon request. For optional spigot on flange side, insert the letter P as seen in the following example: QMFP**J***S.

⁽⁴⁾Six-bolt housing.

TAMC CARTRIDGE BLOCKS

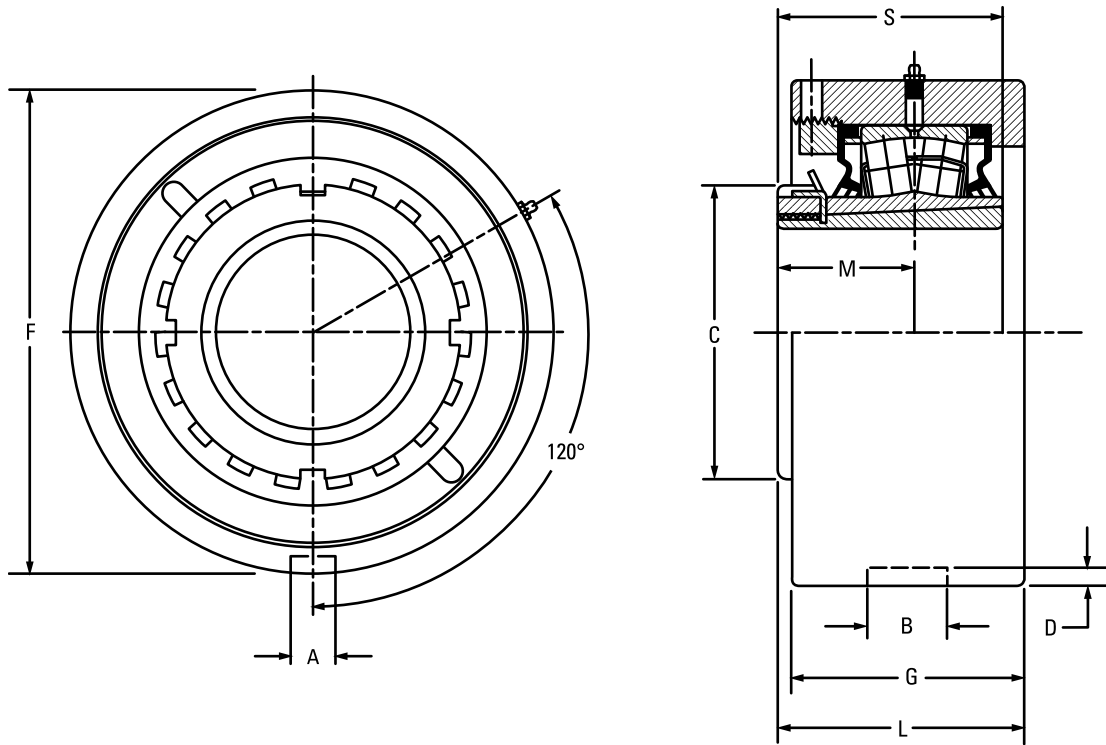

Bearing Part No.	Shaft Dia.	Bearing No.	A	B	C	D	F	G	L _{FIX}	L _{EXP}	M	S	Wt.
	mm in.		mm in.	mm in.	mm in.	mm in.	mm in.	mm in.	mm in.	mm in.	mm in.	mm in.	kg lbs.
TAMC11K115S	1 15/16 in.	22211	13.5	23.0	74.9	4.8	115.09 (+0/-0.05)	55.4	63.2	64.5	35.6	58.9	4.5
TAMC11K200S	2 in.		0.530	0.906	2.95	0.188	4.531 (+0/-0.002)	2.18	2.49	2.54	1.40	2.32	10
TAMC11K050S	50 mm												
TAMC13K203S	2 3/16 in.	22213	13.5	23.0	85.1	4.8	127.00 (+0/-0.05)	67.1	70.9	72.9	39.6	65.0	5.4
TAMC13K204S	2 1/4 in.		0.530	0.906	3.35	0.188	5.000 (+0/-0.002)	2.64	2.79	2.87	1.56	2.56	12
TAMC13K060S	60 mm												
TAMC15K207S	2 7/16 in.	22215	15.1	26.2	98.0	6.4	149.23 (+0/-0.05)	70.6	78.2	80.3	43.9	72.9	8.2
TAMC15K208S	2 1/2 in.		0.594	1.032	3.86	0.250	5.875 (+0/-0.002)	2.78	3.08	3.16	1.73	2.87	18
TAMC15K065S	65 mm												
TAMC17K215S	2 15/16 in.	22217	15.1	27.5	110.0	7.1	171.45 (+0/-0.05)	74.9	87.4	89.4	49.8	82.0	11.8
TAMC17K300S	3 in.		0.594	1.083	4.33	0.281	6.750 (+0/-0.002)	2.95	3.44	3.52	1.96	3.23	26
TAMC17K075S	75 mm												
TAMC20K307S	3 7/16 in.	22220	19.8	32.5	130.0	8.0	206.38 (+0/-0.05)	85.6	101.3	103.4	58.4	97.0	14.5
TAMC20K308S	3 1/2 in.		0.781	1.281	5.12	0.313	8.125 (+0/-0.002)	3.37	3.99	4.07	2.30	3.82	32
TAMC20K090S	90 mm												
TAMC22K315S	3 15/16 in.	22222	19.8	32.5	145.0	8.0	222.25 (+0/-0.08)	97.8	112.0	114.0	63.0	104.9	18.1
TAMC22K400S	4 in.		0.781	1.281	5.71	0.313	8.750 (+0/-0.003)	3.85	4.41	4.49	2.48	4.13	40
TAMC22K100S	100 mm												
TAMC26K407S	4 7/16 in.	22226	19.8	38.1	165.1	8.0	265.10 (+0/-0.08)	104.4	124.2	126.2	71.9	120.9	23.6
TAMC26K408S	4 1/2 in.		0.780	1.500	6.50	0.313	10.437 (+0/-0.003)	4.11	4.89	4.97	2.83	4.76	52
TAMC26K115S	115 mm												

TAKE-UP FRAMES⁽¹⁾

QMTF TAKE-UP FRAMES

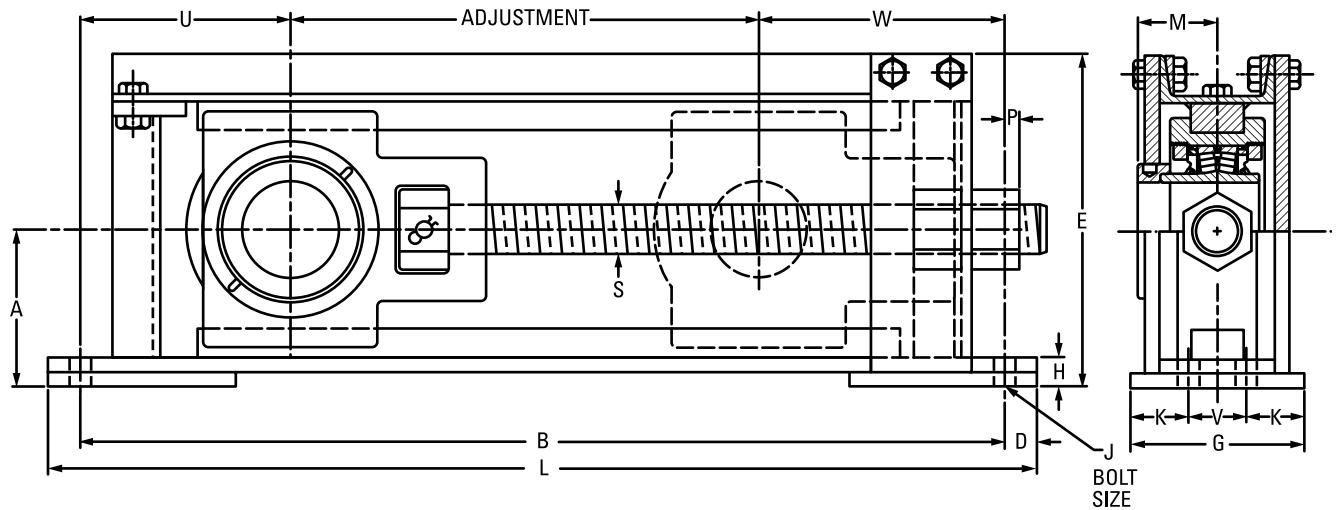

Frame Part No.	Travel Nom.	Travel Adj.	ADJUSTMENT															No. of Bolts Req.	Wt.		
			A	B	D	E	G	H	J	K	L	M	P	S	U	V	W				
			mm in.	mm in.	mm in.	mm in.	mm in.	mm in.	mm in.	mm in.	mm in.	mm in.	mm in.	mm in.	mm in.	mm in.	mm in.	mm in.	mm in.	mm in.	kg lbs.
QMTF12-115	12	419.1 16.50	100.1 3.94	698.5 27.50	25.4 1.00	210.3 8.28	101.6 4.00	31.8 1.25	16 5/8	-	749.3 29.50	47.8 1.88	31.8 1.25	1-5 ACME	136.7 5.38	-	143.0 5.63	2	27.2 60		
QMTF12-203	12	431.8 17.00	106.4 4.19	698.5 27.50	25.4 1.00	220.0 8.66	101.6 4.00	35.1 1.38	16 5/8	-	749.3 29.50	50.8 2.00	41.4 1.63	1.125-5 ACME	115.8 4.56	-	150.9 5.94	2	29.5 65		
QMTF12-207	12	421.6 16.60	111.3 4.38	723.9 28.50	25.4 1.00	233.4 9.19	101.6 4.00	28.7 1.13	20 3/4	-	774.7 30.50	54.1 2.13	44.5 1.75	1.25-5 ACME	134.9 5.31	-	166.6 6.56	2	32.2 71		
QMTF12-215	12	393.7 15.50	129.3 5.09	774.7 30.50	25.4 1.00	272.8 10.74	127.0 5.00	28.7 1.13	16 5/8	38.1 1.50	825.5 32.50	60.5 2.38	12.7 0.50	1.5-4 ACME	165.1 6.50	50.8 2.00	215.9 8.50	4	49.4 109		
QMTF12-307	12	393.7 15.50	143.0 5.63	812.8 32.00	28.7 1.13	295.4 11.63	127.0 5.00	26.2 1.03	20 3/4	38.1 1.50	870.0 34.25	65.5 2.58	25.4 1.00	1.75-4 ACME	185.7 7.31	50.8 2.00	233.4 9.19	4	62.6 138		
QMTF12-315	12	457.2 18.00	177.8 7.00	914.4 36.00	31.8 1.25	367.5 14.47	152.4 6.00	36.6 1.44	20 3/4	44.5 1.75	977.9 38.50	75.2 2.96	41.4 1.63	2-4 ACME	190.5 7.50	63.5 2.50	265.2 10.44	4	86.6 191		
QMTF18-207	18	574.0 22.60	111.3 4.38	876.3 34.50	25.4 1.00	234.2 9.22	101.6 4.00	26.9 1.06	20 3/4	-	927.1 36.50	54.1 2.13	44.5 1.75	1.25-5 ACME	139.7 5.50	-	162.6 6.40	2	36.7 81		
QMTF18-215	18	546.1 21.50	129.3 5.09	927.1 36.50	25.4 1.00	272.8 10.74	127.0 5.00	28.7 1.13	16 5/8	38.1 1.50	977.9 38.50	60.5 2.38	12.7 0.50	1.5-4 ACME	165.1 6.50	50.8 2.00	215.9 8.50	4	54.4 120		
QMTF18-307	18	546.1 21.50	143.0 5.63	965.2 38.00	28.7 1.13	295.4 11.63	127.0 5.00	26.2 1.03	20 3/4	38.1 1.50	1022.4 40.25	65.5 2.58	25.4 1.00	1.75-4 ACME	185.7 7.31	50.8 2.00	233.4 9.19	4	70.8 156		
QMTF18-315	18	609.6 24.00	177.8 7.00	1066.8 42.00	31.8 1.25	366.8 14.44	152.4 6.00	36.6 1.44	20 3/4	44.5 1.75	1130.3 44.50	75.2 2.96	41.4 1.63	2-4 ACME	190.5 7.50	63.5 2.50	265.2 10.44	4	101.2 223		
QMTF24-207	24	726.4 28.60	111.3 4.38	1028.7 40.50	25.4 1.00	233.4 9.19	101.6 4.00	28.7 1.13	20 3/4	-	1079.5 42.50	54.1 2.13	44.5 1.75	1.25-5 ACME	115.8 4.56	-	166.6 6.56	2	41.3 91		
QMTF24-215	24	698.5 27.50	129.3 5.09	1079.5 42.50	25.4 1.00	271.5 10.69	127.0 5.00	24.6 0.97	16 5/8	38.1 1.50	1130.3 44.50	60.5 2.38	12.7 0.50	1.5-4 ACME	165.1 6.50	50.8 2.00	215.9 8.50	4	64.0 141		
QMTF24-307	24	698.5 27.50	143.0 5.63	1117.6 44.00	28.7 1.13	295.4 11.63	127.0 5.00	26.2 1.03	20 3/4	38.1 1.50	1174.8 46.25	65.5 2.58	25.4 1.00	1.75-4 ACME	185.7 7.31	50.8 2.00	233.4 9.19	4	81.2 179		
QMTF24-315	24	762.0 30.00	177.8 7.00	1219.2 48.00	31.8 1.25	367.5 14.47	152.4 6.00	36.6 1.44	20 3/4	44.5 1.75	1282.7 50.50	75.2 2.96	41.4 1.63	2-4 ACME	190.5 7.50	63.5 2.50	265.2 10.44	4	112.9 249		

⁽¹⁾Frame only. Bearing unit must be ordered separately. See pages 80 (V-Lock), 107 (CL) and 137 (EC) for information on take-up bearing units.
NOTE: All take-up frames come with Acme threaded rod.

QMT PILLOW BLOCK TAKE-UP FRAMES⁽¹⁾

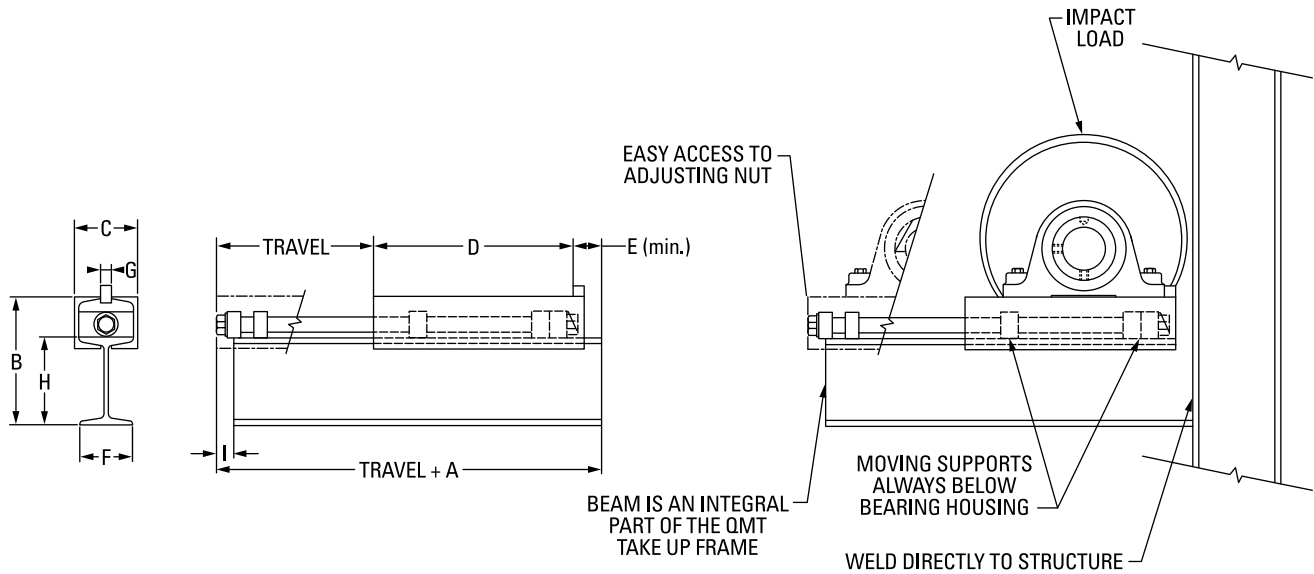

Frame Part No.	Bearing Size	Travel	A	B	C	D	E	F	G	H	I	Wt.
			mm in.	mm in.	mm in.	mm in.	mm in.	mm in.	mm in.	mm in.	mm in.	kg lbs.
QMT1 X 9	1 7/16 in. – 2 15/16 in.	9	330.2 13.0	187.3 7.375	92.1 3.625	289.1 11.38	41.4 1.63	76.2 3.00	20 3/4	127.0 5.0	25.4 1.0	11.8 26
QMT1 X 12	1 7/16 in. – 2 15/16 in.	12	330.2 13.0	187.3 7.375	92.1 3.625	289.1 11.38	41.4 1.63	76.2 3.00	20 3/4	127.0 5.0	25.4 1.0	13.6 30
QMT1 X 18	1 7/16 in. – 2 15/16 in.	18	330.2 13.0	187.3 7.375	92.1 3.625	289.1 11.38	41.4 1.63	76.2 3.00	20 3/4	127.0 5.0	25.4 1.0	16.3 36
QMT1 X 24	1 7/16 in. – 2 15/16 in.	24	330.2 13.0	187.3 7.375	92.1 3.625	289.1 11.38	41.4 1.63	76.2 3.00	20 3/4	127.0 5.0	25.4 1.0	19.1 42
QMT2 X 18	2 15/16 in. – 4 7/16 in.	18	482.6 19.0	311.2 12.25	125.4 4.938	431.8 17.00	50.8 2.00	106.4 4.19	24 1	203.2 8.0	38.1 1.5	33.6 74
QMT2 X 24	2 15/16 in. – 4 7/16 in.	24	482.6 19.0	311.2 12.25	125.4 4.938	431.8 17.00	50.8 2.00	106.4 4.19	24 1	203.2 8.0	38.1 1.5	40.8 90
QMT2 X 36	2 15/16 in. – 4 7/16 in.	36	482.6 19.0	311.2 12.25	125.4 4.938	431.8 17.00	50.8 2.00	106.4 4.19	24 1	203.2 8.0	38.1 1.5	43.6 96

⁽¹⁾Frame only. Bearing unit must be ordered separately.
NOTE: All take-up frames come with Acme threaded rod.

INDEX**SPHERICAL ROLLER BEARING SOLID-BLOCK HOUSED UNITS**

DVC Piloted Flange Cartridges	171	QVFB and QVFB Flange Blocks – Tapered Bore Equivalent.	97
DVF Square Flange Blocks	174	QVFC and QVFC Piloted Flange Cartridges – Tapered Adapter Equivalent.	98
DVP Two-Bolt Pillow Blocks	163	QVFK and QVFK 9000 Series Square Flange Blocks – Tapered Bore Equivalent	101
DVPF Four-Bolt Pillow Blocks	167	QVFL and QVFL Square Flange Blocks – Straight Bore Equivalent.	99
Engineering	13	QVFX and QVFX 5000 Series Square Flange Blocks – Straight Bore Equivalent.	100
QAAFX 5000 Series Flange Blocks	128	QVfy and QVfy Round Flange Blocks – Straight Bore Equivalent.	102
QAAPX 5000 Series Four-Bolt Pillow Blocks	119	QVMC and QVMC Cartridge Blocks – Tapered Bore Equivalent	105
QAAPXT 5000 Series Two-Bolt Pillow Blocks	115	QVVP Two-Bolt Pillow Blocks – Straight Bore Equivalent	83
QAC and QAC Piloted Flange Cartridges	120	QVVA SAF Two-Bolt Pillow Blocks – Tapered Bore Equivalent	85
QACW and QACW Piloted Flange Cartridges	122	QVVPF Four-Bolt Pillow Blocks – Straight Bore Equivalent	89
QAF and QAF Square Flange Blocks	124	QVVPK SN-Style Four-Bolt Pillow Blocks Tapered Bore Equivalent	93
QAFI and QAFI Square Flange Blocks	126	QVVPK SAF-Style Four-Bolt Pillow Blocks – Tapered Bore Equivalent	94
QAFY and QAFY Round Flange Blocks	129	QVVPK 9000 Series Four-Bolt Pillow Blocks – Tapered Bore Equivalent	95
QAMC and QAMC Cartridge Blocks	131	QVVPK 9000 Series Two-Bolt Pillow Blocks – Tapered Bore Equivalent	88
QAMH and QAMH Hanger Blocks	135	QVVPK Two-Bolt Pillow Blocks – Straight Bore Equivalent	84
QAP and QAP Two-Bolt Pillow Blocks	109	QVVPK SN-Style Two-Bolt Pillow Blocks – Tapered Bore Equivalent	86
QAPF and QAPF Four-Bolt Pillow Blocks	116	QVVPK Four-Bolt Pillow Blocks – Straight Bore Equivalent	90
QAPL and QAPL Two-Bolt Pillow Blocks	111	QVVPK 5000 Series Four-Bolt Pillow Blocks – Straight Bore Equivalent.	91
QAPR and QAPR Four-Bolt Pillow Blocks	118	QVVPK 5000 Series Two-Bolt Pillow Blocks – Straight Bore Equivalent.	92
QASN and QASN SN-Style Two-Bolt Pillow Blocks – Pure Metric Design	113	QVVPK SN-Style Two-Bolt Pillow Blocks – Pure Metric Design	87
QATU and QATU Take-Up Blocks	133	QVVPK Take-Up Blocks – Straight Bore Equivalent.	106
QMC Piloted Flange Cartridges	148	Seal and Cover Options	65
QMCW Piloted Flange Cartridges	149	Spherical Roller Bearing Solid-Block Housed Unit Product Data Tables	59
QMF Four-Bolt Square Flange Blocks	151	TAFB Square Flange Blocks	173
QMFL Four-Bolt Square Flange Blocks	152	TAFB Square Piloted Flange Cartridges	172
QMF 5000 Series Square Flange Blocks	155	TAFK 9000 Series Square Flange Blocks	175
QMFY Round Flange Blocks	153	Take-Up Frames	177
QMMC Cartridge Blocks	158	TAMC Cartridge Blocks	176
QMMH Hanger Blocks	160	TAPA SAF-Style Two-Bolt Pillow Blocks	164
QMP Two-Bolt Pillow Blocks	139	TAPG SN-Style Four-Bolt Pillow Blocks	170
QMPF Four-Bolt Pillow Blocks	141	TAPH SAF-Style Four-Bolt Pillow Blocks	169
QMPH/QMPG Four-Bolt Pillow Blocks	143	TAPK 9000 Series Four-Bolt Pillow Blocks	168
QMPL Two-Bolt Pillow Blocks	140	TAPK 9000 Series Two-Bolt Pillow Blocks	166
QMPR Four-Bolt Pillow Blocks	142	TAPN SN-Style Two-Bolt Pillow Blocks	165
QMPX 5000 Series Four-Bolt Pillow Blocks	144		
QMPXT 5000 Series Two-Bolt Pillow Blocks	145		
QMSN SN-Style Two-Bolt Pillow Blocks – Pure Metric Design	146		
QMT Pillow Block Take-Up Frames	178		
QMTF Take-Up Frames	177		
QMTU Take-Up Blocks	157		
QVC and QVC Piloted Flange Cartridges – Straight Bore Equivalent.	103		
QVCW and QVCW Piloted Flange Cartridges – Straight Bore Equivalent.	104		
QVF and QVF Square Flange Blocks – Straight Bore Equivalent.	96		

TIMKEN

The Timken team applies their know-how to improve the reliability and performance of machinery in diverse markets worldwide. The company designs, makes and markets high-performance mechanical components, including bearings, gears, chain and related mechanical power transmission products and services.

www.timken.com